

MCRP 5-12D

Organization of Marine Corps Forces



U.S. Marine Corps

DISTRIBUTION STATEMENT A: Approved for public release; distribution is unlimited

PCN 144 000050 00

To Our Readers

Changes: Readers of this publication are encouraged to submit suggestions and changes that will improve it. Recommendations may be sent directly to Commanding General, Marine Corps Combat Development Command, Doctrine Division (C 42), 3300 Russell Road, Suite 318A, Quantico, VA 22134-5021 or by fax to 703-784-2917 (DSN 278-2917) or by e-mail to **smb@doctrine div@mccdc**. Recommendations should include the following information:

- w Location of change
 - Publication number and title
 - Current page number
 - Paragraph number (if applicable)
 - Line number
 - Figure or table number (if applicable)
- w Nature of change
 - Add or delete
 - Proposed new text, preferably double spaced and typewritten
- w Justification for and/or source of change

Additional copies: A printed copy of this publication may be obtained from Marine Corps Logistics Base, Albany, GA 31704-5001, by following the instructions in MCBul 5600, *Marine Corps Doctrinal Publications Status*. An electronic copy may be obtained from the Doctrine Division, MCCDC, world wide web home page which is found at the following uniform resource locator: **<http://www.doctrine.quantico.usmc.mil>**.

Unless otherwise specified, masculine nouns and pronouns used in this publication refer to both men and women.

DEPARTMENT OF THE NAVY
Headquarters United States Marine Corps
Washington, D.C. 20380-1775

FOREWORD

113 October 1998

1. PURPOSE

Marine Corps reference publication (MCRP) 5-12D, *Organization of Marine Corps Forces*, provides general information on the mission, concept of employment, organization, and equipment of the Marine Corps forces.

2. SCOPE

This publication addresses the mission, organization, equipment, and concept of employment of Marine Corps Forces Atlantic, Marine Corps Forces Pacific, and the Marine Corps Reserve, as well as subordinate organizations thereof, through 1 September 1998. However, due to the frequent changes in organization, the tables of organization will be reviewed and this publication will be updated annually. This publication does not discuss in any detail Marine Corps Security Forces, the Marine Security Guard Battalion, or the Marine Corps supporting establishment. *This publication should be considered only a guide based on current Marine Corps tables of organization and equipment, and not as a replacement for those tables.* This reference publication is primarily intended for Marine commanders, their staffs, and Marine Corps training and education institutions, although all Marines may find it useful. It may also prove valuable to joint force commanders and their staffs in planning and executing operations involving Marine Corps forces.

3. SUPERSESION

MCRP 5-12D supersedes Fleet Marine Force reference publication (FMFRP) 1-11, *Fleet Marine Force Organization—1992*, dated 2 March 1992.

4. CERTIFICATION

Reviewed and approved this date.

BY DIRECTION OF THE COMMANDANT OF THE MARINE CORPS



J. E. RHODES

Lieutenant General, U.S. Marine Corps
Commanding General
Marine Corps Combat Development Command
Quantico, Virginia

DISTRIBUTION: 144 000050 00

Organization of Marine Corps Forces

Table of Contents

	Page
Chapter 1. The Marine Corps	
1001. Introduction	1-1
1002. Organization and Chain of Command	1-1
1003. Marine Corps Operating Forces	1-1
1004. Marine Corps Forces Reserve (MARFORRES)	1-3
1005. Supporting Establishment	1-6
1006. Headquarters, U.S. Marine Corps	1-6
Chapter 2. Marine Air-Ground Task Forces	
2001. General	2-1
2002. Marine Expeditionary Force	2-2
2003. Marine Expeditionary Unit (Special Operations Capable)	2-4
2004. Special Purpose Marine Air-Ground Task Force	2-5
Chapter 3. Marine Aircraft Wings	
Section I. Fundamentals	
3101. General	3-1
3102. Expeditionary Aspects	3-1
3103. Functions	3-1
3104. Marine Aviation Organization	3-3
Section II. Marine Aircraft Wing	
3201. General	3-8
3202. Marine Wing Headquarters Squadron (MWHS)	3-8
Section III. Marine Air Control Group	
3301. General	3-10
3302. Marine Air Control Group Headquarters	3-10

3303.	Marine Tactical Air Command Squadron	3-11
3304.	Marine Air Control Squadron	3-12
		Page
3305.	Marine Wing Communications Squadron	3-15
3306.	Marine Air Support Squadron	3-17
3307.	Low-Altitude Air Defense Battalion	3-17

Section IV. Marine Aircraft Group (MAG)

3401.	General	3-20
3402.	Marine Air Group Headquarters	3-20
3403.	Marine Aviation Logistics Squadron: Fixed Wing/Rotary Wing	3-22
3404.	Marine Aerial Refueler Transport Squadron	3-23
3405.	Marine Tactical Electronic Warfare Squadron	3-23
3406.	Marine Unmanned Aerial Vehicle Squadron	3-24
3407.	Marine Fighter Attack Squadron	3-25
3408.	Marine All-Weather Fighter Attack Squadron	3-26
3409.	Marine Attack Squadron	3-27
3410.	Marine Heavy Helicopter Squadron (CH-53D)	3-27
3411.	Marine Heavy Helicopter Squadron (CH-53E)	3-28
3412.	Marine Medium Helicopter Squadron	3-29
3413.	Marine Light/Attack Helicopter Squadron	3-30

Section V. Marine Wing Support Group

3501.	General	3-32
3502.	Headquarters and Headquarters Squadron	3-32
3503.	Marine Wing Support Squadron: Fixed Wing/Rotary Wing	3-33

Chapter 4. Marine Divisions

4001.	Marine Division	4-1
4002.	Headquarters Battalion, Marine Division	4-2
4003.	Infantry Regiment, Marine Division	4-3
4004.	Infantry Battalion, Infantry Regiment	4-5
4005.	Artillery Regiment, Marine Division	4-9
4006.	Artillery Battalion, Artillery Regiment	4-10
4007.	Tank Battalion, Marine Division	4-11
4008.	Assault Amphibian Battalion, Marine Division	4-13
4009.	Combat Engineer Battalion, Marine Division	4-14
4010.	H&S Company, Combat Engineer Battalion	4-16

4011.	Engineer Support Company, Combat Engineer Battalion	4-18
4012.	Combat Engineer Company, Combat Engineer Battalion	4-20
4013.	Light Armored Reconnaissance (LAR) Battalion	4-22
4014.	Marine Corps Forces Reserve	4-24

Page

Chapter 5. Marine Force Service Support Groups

5001.	General	5-1
5002.	Force Service Support Group Command Element	5-1
5003.	Headquarters and Service Battalion	5-5
5004.	Headquarters Company, Headquarters and Service Battalion	5-7
5005.	Service Company, Headquarters and Service Battalion	5-9
5006.	Communications Company, Headquarters and Service Battalion	5-11
5007.	Military Police Company, Headquarters and Service Battalion	5-13
5008.	Maintenance Battalion	5-15
5009.	Headquarters and Service Company, Maintenance Battalion	5-17
5010.	Ordnance Maintenance Company, Maintenance Battalion	5-19
5011.	Engineer Maintenance Company, Maintenance Battalion	5-21
5012.	Electronics Maintenance Company, Maintenance Battalion	5-23
5013.	Motor Transport Maintenance Company, Maintenance Battalion	5-25
5014.	General Support Maintenance Company, Maintenance Battalion	5-27
5015.	Supply Battalion	5-29
5016.	Headquarters and Service Company, Supply Battalion	5-31
5017.	Supply Company, Supply Battalion	5-32
5018.	Ammunition Company, Supply Battalion	5-35
5019.	Medical Logistics Company, Supply Battalion	5-37
5020.	Engineer Support Battalion	5-38
5021.	Headquarters and Service Company, Engineer Support Battalion	5-40
5022.	Engineer Support Company, Engineer Support Battalion	5-42
5023.	Bridge Company, Engineer Support Battalion	5-44
5024.	Bulk Fuel Company, Engineer Support Battalion	5-46
5025.	Engineer Company, Engineer Support Battalion	5-48
5026.	Landing Support Battalion (LSB)	5-51
5027.	Headquarters and Service Company, Landing Support Battalion	5-53
5028.	Landing Support Equipment Company, Landing Support Battalion	5-54
5029.	Beach and Terminal Operations Company, Landing Support Battalion	5-56
5030.	Landing Support Company, Landing Support Battalion	5-58
5031.	Motor Transport Battalion	5-60
5032.	Headquarters and Service Company, Motor Transport Battalion	5-62
5033.	General Support Company, Motor Transport Battalion	5-63
5034.	Direct Support Company, Motor Transport Battalion	5-65
5035.	Medical Battalion	5-67
5036.	Headquarters and Service Company, Medical Battalion	5-69

5037.	Surgical Support Company, Medical Battalion	5-70
5038.	Shock-Trauma Platoon, Headquarters and Service Company, Medical Battalion	5-73

		Page
5039.	Dental Battalion	5-75
5040.	Headquarters and Service Company, Dental Battalion	5-76
5041.	Dental Company, Dental Battalion	5-78

Chapter 6. MAGTF Command Elements and Supporting Units

6001.	General	6-1
6002.	Marine Expeditionary Force Command Element	6-1
6003.	Marine Expeditionary Unit, Special Operations Capable [MEU (SOC)] CE	6-3
6004.	Marine Expeditionary Force (MEF) Headquarters Group (MHG)	6-5
6005.	Radio Battalion	6-6
6006.	Intelligence Company	6-8
6007.	Counterintelligence (CI)/Human Intelligence (HUMINT) Company	6-13
6008.	Marine Corps Imagery Support Unit	6-16
6009.	Force Reconnaissance Company	6-18
6010.	Communication Battalion	6-20
6011.	Civil Affairs Group (CAG)	6-23

Appendix A. Glossary

Chapter 1

The Marine Corps

1001. Introduction

The Marine Corps, within the Department of the Navy, is organized as a general purpose “force in readiness” to support national needs. Deploying for combat as combined-arms Marine air-ground task forces (MAGTFs), the Marine Corps provides the National Command Authorities (NCA) with a responsive force that can conduct operations across the spectrum of conflict. Recent events continue to highlight the Navy-Marine Corps team’s key national security role. Seabased, combat ready, forward deployed naval forces have been involved in more than 28 major military operations since 1995. Whether responding to natural disasters or to the specter of regional aggression, Navy and Marine forces provide self-contained and self-sustained air, land, and sea strike forces, operating from a protected sea base, that can be tailored to meet any contingency.

1002. Organization and Chain of Command

Two parallel chains of command—Service and operational—exist within the Marine Corps. The Service chain begins with the President, through the Secretary of Defense, and continues through the Secretary of the Navy and the Commandant of the Marine Corps. The operational chain runs from the President, through the Secretary of Defense, directly to commanders of combatant commands for missions and forces assigned to their commands. Marine Corps component commanders provide operational forces to commanders of combatant commands and other operational commanders as required.

The Marine Corps is divided into four broad categories: operating forces; the Marine Corps

Reserve; the supporting establishment; and Headquarters, U.S. Marine Corps.

1003. Marine Corps Operating Forces

The Marine Corps’ operating forces consist of:

- w Marine Corps forces (MARFOR)
- w Marine Corps security forces (MCSF) at naval installations
- w Marine security guard detachments at embassies and consulates around the globe.

The “Forces for Unified Commands” memorandum assigns Marine Corps operating forces to each of the combatant commands. A force assigned or attached to a combatant command may be transferred from that command only as directed by the Secretary of Defense and under procedures prescribed by the Secretary of Defense and approved by the President. The Marine Corps has established multiple Marine Corps component headquarters to support the unified commands.

a. Marine Corps forces are organized as MAGTFs and are either employed as part of naval expeditionary forces or separately as part of larger joint or combined forces.

The commanders of MARFOR Atlantic and Pacific serve as Marine Corps component commanders to their respective combatant commanders and may also serve as commanding generals of Fleet Marine Forces (FMFs) Atlantic, Pacific, and Europe. As commanding generals, with the status of a naval type commander, they provide forces for service with Commander US Atlantic Fleet, Commander US

Pacific Fleet, and Commander US Naval Forces Europe, respectively. (See figure 1-1.)

The Marine Corps component commander deals directly with the joint force commander (JFC) in matters affecting assigned MARFOR. He commands, trains, equips, and sustains MARFOR. As such, he is responsible for:

- w Making recommendations to the JFC on the proper employment of Marine forces.
- w Accomplishing such operational missions as may be assigned.
- w Selecting and nominating specific Marine units or forces for assignment to other subordinate forces of the combatant command.
- w Conducting joint training, including the training, as directed, of components of other Services in joint operations for which the Service component commander has or may be assigned primary responsibility or for which the Service component facilities and capabilities are suitable.
- w Informing the JFC (and the combatant commander, if affected) of planning for changes in logistic support that would significantly affect operational capability or sustainability sufficiently early in the planning process for the JFC to evaluate the proposals before final decision or implementation. If the combatant commander does not approve the proposal and discrepancies cannot be resolved between the combatant commander and the Service component commander, the combatant commander will forward the issue through the Chairman of the Joint Chiefs of Staff (JCS) to the Secretary of Defense for resolution. Under crisis action or wartime conditions, and where critical situations make diversion of the normal logistic process necessary, Service component commanders will implement directives issued by the combatant commander.
- w Developing program and budget requests that comply with combatant commander guidance on warfighting requirements and priorities.
- w Informing the combatant commander (and any intermediate JFCs) of program and budget decisions that may affect joint operation planning.
- w Providing supporting operation and exercise plans to support assigned missions.

Although there are five Marine Corps components, there are only two Marine Corps component commands. The Marine Corps has established two combatant command-level Service component commands: Marine Corps Forces, Atlantic, and Marine Corps Forces, Pacific. The II Marine Expeditionary Force is provided by Commander, Marine Corps Forces, Atlantic, to the Commander in Chief, U.S. Atlantic Command, and the I and III Marine Expeditionary Forces are provided by Commander, Marine Corps Forces, Pacific, to the Commander in Chief, U.S. Pacific Command. This assignment reflects the peacetime disposition of Marine Corps forces. Marine expeditionary forces are apportioned to the remaining geographic combatant commands for contingency planning and are provided to the combatant commands when directed by the Secretary of Defense.

The Commander, Marine Corps Forces, Atlantic, is assigned to the Commander in Chief, U.S. Atlantic Command, and the Commander, Marine Corps Forces, Pacific, is assigned to the Commander in Chief, U.S. Pacific Command. In order to provide three-star, general officer representation to the remaining three geographic combatant commands, Commander, Marine Corps Forces, Atlantic (COMMARFORLANT), is designated as the Marine Corps component commander to both Commander in Chief, U.S. European Command (CINCUSEUCOM), and Commander in Chief, U.S. Southern Command (CINCUSOCOM). The Commander, Marine Corps Forces, Pacific, is designated as the Marine Corps component commander

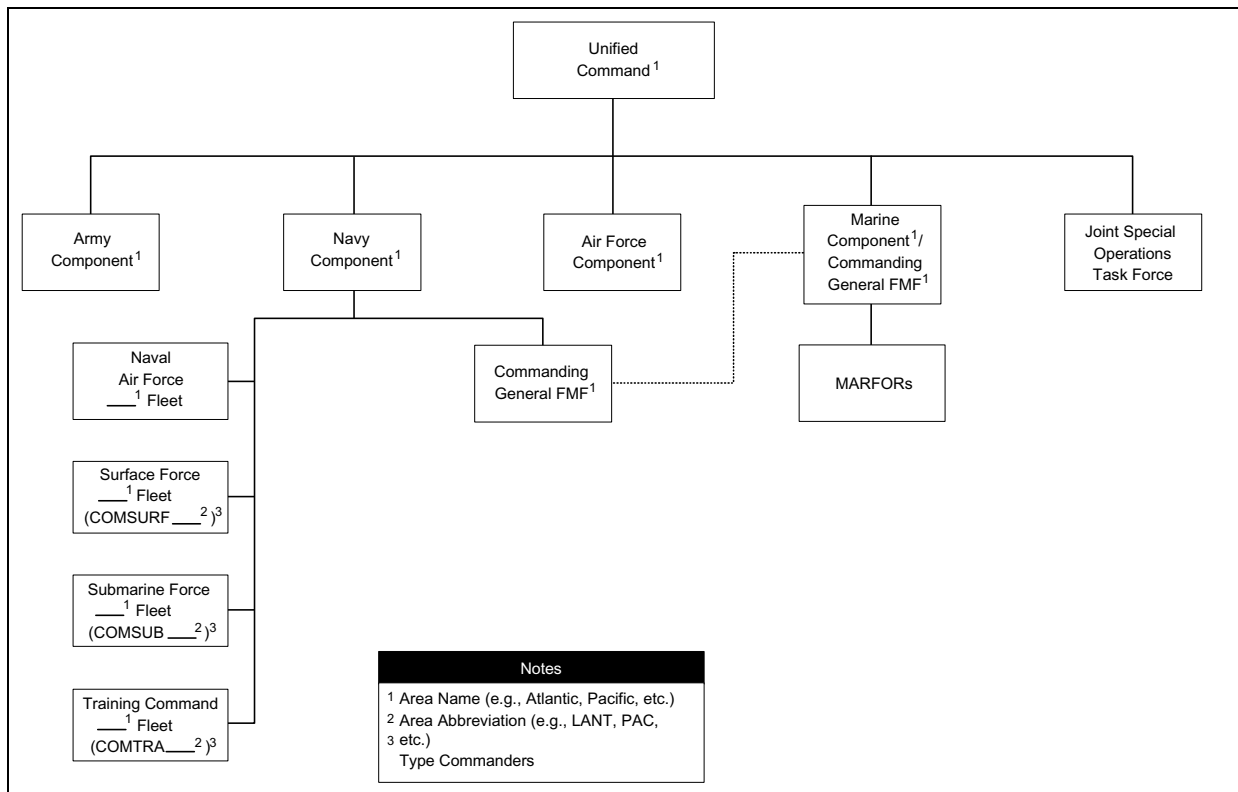

Figure 1-1. Command Relationships.

to the Commander in Chief, U.S. Central Command (CINCUSCENTCOM).

Headquarters, Marine Corps Forces, Europe, has been established in the European Command (EUCOM) and a planning liaison element has been established with both Central Command and Southern Command to support their respective designated Marine Corps component commander. During peacetime, the designated Marine Corps component commander provides operation and contingency planning support and advice to his respective combatant commanders on Marine Corps-specific matters. When directed, the Marine Corps component commander exercises operational control (OPCON) of forces assigned or attached to the combatant commander.

Additionally, Commander, Marine Corps Forces, Pacific (COMMARFORPAC), possesses the capability to deploy a combatant command-level Marine Corps component headquarters. This capability is required due to the unique nature of the supported combatant commands.

b. The MCSF include approximately 3,400 Marines who protect key naval installations and facilities worldwide. Although not assigned to combatant commands, they are part of the operating forces of the Marine Corps. These security forces include Marine barracks and Marine security force companies in the continental United States (CONUS) and abroad, as well as Marine detachments afloat.

c. The Marine security guard battalion provides forces to the Department of State for embassy security. These Marines are currently assigned to 121 diplomatic posts in 115 countries throughout the world. (See figures 1-2 and 1-3.)

1004. Marine Corps Forces Reserve (MARFORRES)

a. The MARFORRES is a vital element of the Marine Corps total force and is organized under the Commander, Marine Corps Forces Reserve (COMMARFORRES). (See figure 1-4.) It can augment and reinforce any operations in which MARFOR participate and contains some capabilities

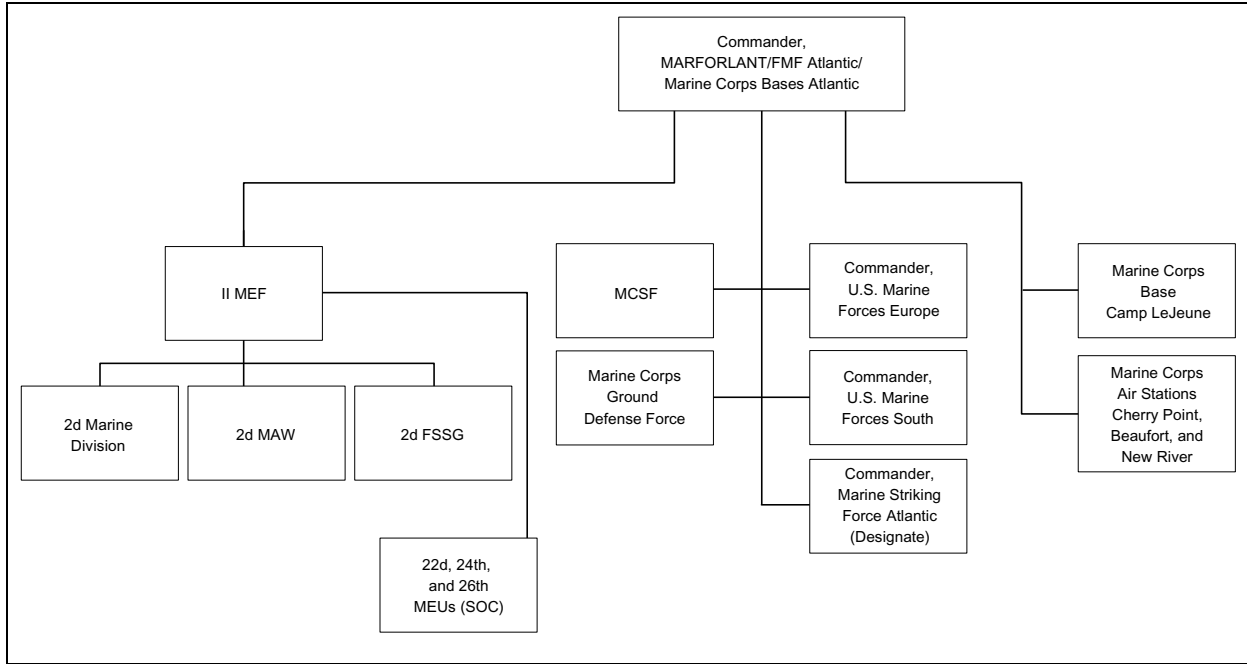
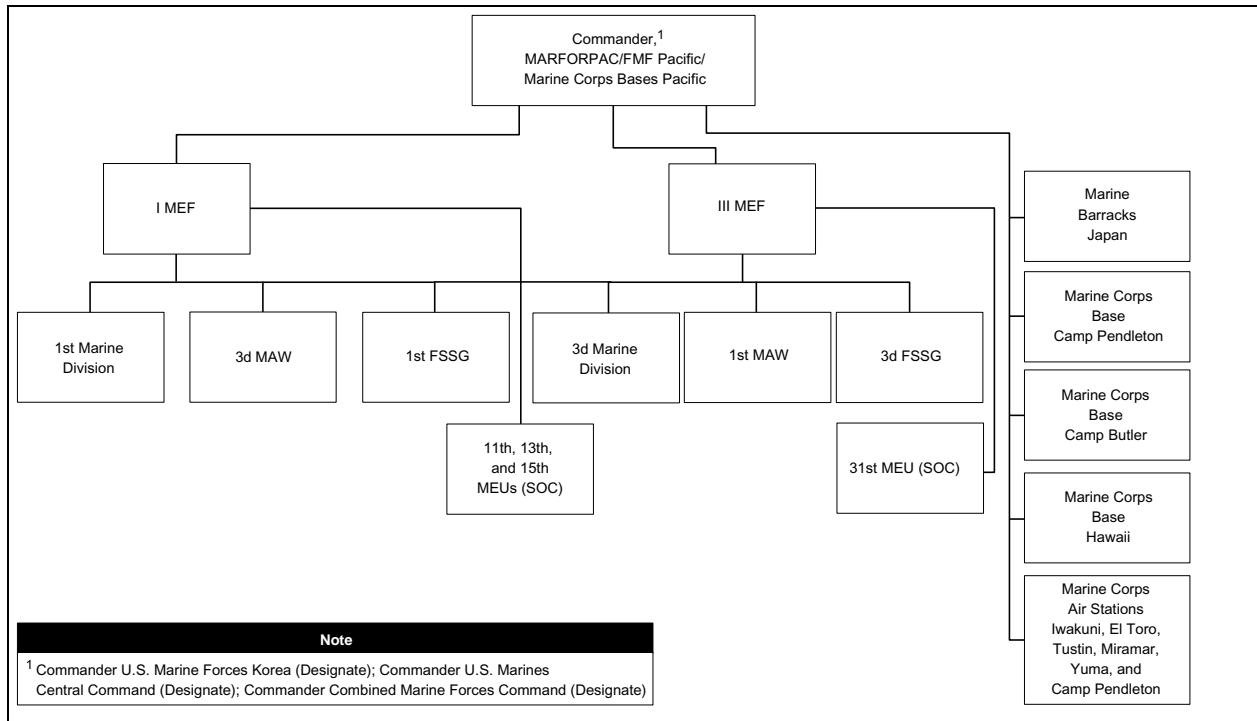

Figure 1-2. MARFORLANT.



Note
¹ Commander U.S. Marine Forces Korea (Designate); Commander U.S. Marines Central Command (Designate); Commander Combined Marine Forces Command (Designate)

Figure 1-3. MARFORPAC.

that are not resident in the active forces, such as civil affairs (CA) and graves registration. The Marine Corps total force consists of the active component, the Reserve component, and retired personnel. Force expansion is made possible by the activation of the MARFORRES, which, like the active forces, consists of a combined-arms force with ground, aviation, and CSS units. The Marine Corps Mobilization Management Plan (MPLAN), dated 7 November 1997, provides detailed guidance and procedures for mobilizing/recalling members of the Reserve. Graduated Mobilization Response (GMR) is the ongoing process of providing a viable deterrent capability to meet a crisis/contingency at the lowest possible level and sequentially build a response force that is appropriate to the threat. The President may authorize recall of up to 200,000 Selected Reservists (including individual mobilization augmentees (IMAs)) to active duty for a period of 270 days. Under this authority, Selected Marine Corps Reserve (SMCR) units organized to serve as units must be activated as units.

b. Organized under COMMARFORRES, the MARFORRES includes the 4th Marine Division, the 4th Marine Air Wing (MAW), and the 4th Force

Service Support Group (FSSG). The subordinate units of these commands are located at 191 training centers in 46 states, Puerto Rico, and the District of Columbia. COMMARFORRES provides SMCR units and individual augmentees to the active duty MARFOR when directed by the NCA through the commandant of the Marine Corps.

c. The MARFORRES is composed of the:

(1) Ready Reserve

The Ready Reserve consists of those units and members of a Reserve component who are liable for active duty in time of war or national emergency as proclaimed by the President or declared by Congress or when otherwise authorized by law. Included in the Ready Reserve are the SMCR and the Individual Ready Reserve (IRR).

(a) SMCR. The SMCR includes units and individual members who participate in scheduled drills and a two-week annual active duty period for training purposes (annual training duty).

(b) IRR. The IRR generally consists of Marines who have recently served in the active forces or

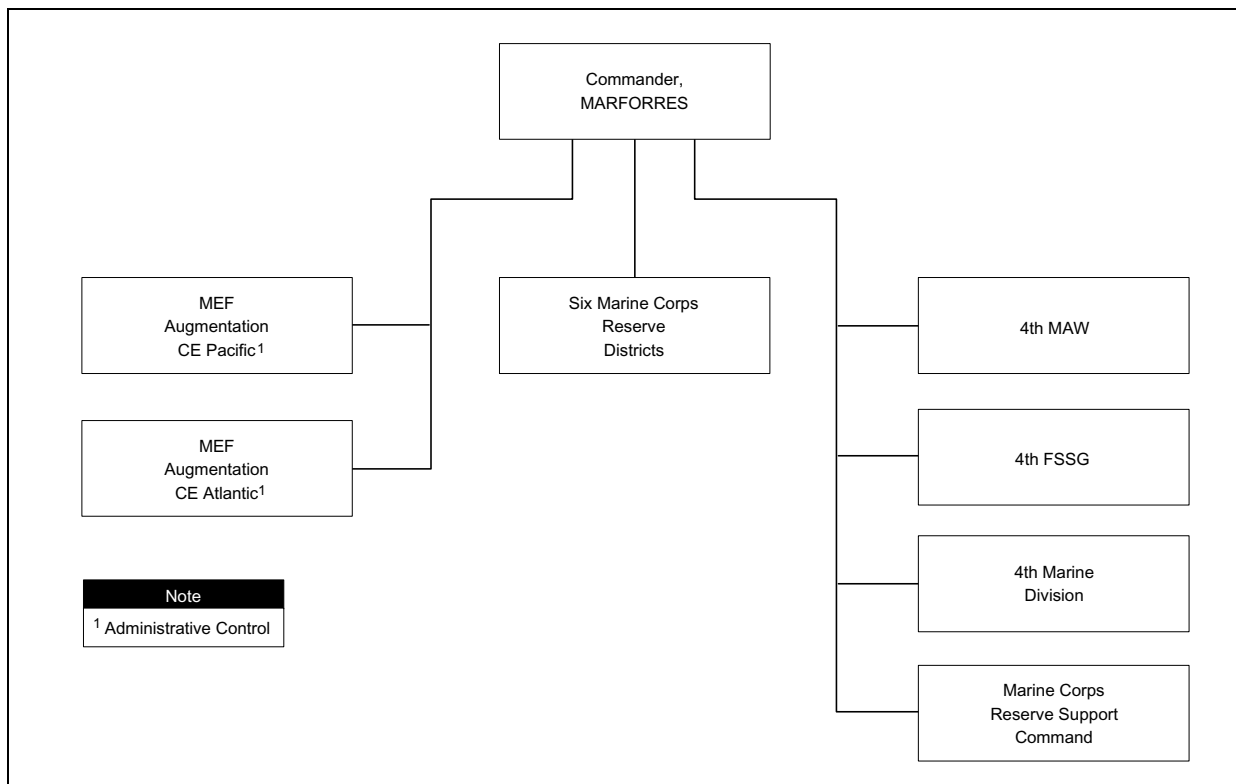

Figure 1-4. Marine Corps Reserve.

SMCR and have a period of obligated service remaining on their contract. The majority of IRR members do not participate in Reserve training and are not members of the SMCR. Members of the Delayed Entry Program also belong to the IRR.

(2) Standby Reserve

The Standby Reserve is composed of Marines not in the Ready or Retired Reserve who are subject to recall to active duty in time of war or a national emergency as declared by Congress.

(3) Retired Reserve

The Retired Reserve includes reservists who are retired under various laws and regulations. Retired Reserves may be mobilized under conditions similar to those for Standby Reserve mobilization.

d. Marine Expeditionary Force (MEF) Augmentation Command Element (CE) (MACE)

Organized to support the MEF CE, a MACE includes approximately 166 Reserve Marines who are activated during a major theater war or any contingency that may require additional support. Both I MEF and II MEF have an assigned MACE. The MACE provides additional personnel to all staff sections, provides additional liaison officers, and conducts command and control in rear area operations.

1005. Supporting Establishment

The Marine Corps supporting establishment consists of those personnel, bases, and activities that support the Marine Corps operating forces. This infrastructure consists primarily of 16 major bases and stations in the United States and Japan and all the personnel, equipment, and facilities required to operate them. This equates to approximately 30,000 Marines. The

supporting establishment also includes the Marine Corps Recruiting Command, the Marine Corps Combat Development Command and the Marine Corps Systems Command, as well as all training activities and formal schools. Additionally, the supporting establishment includes those civilian activities and agencies that provide support to MARFOR.

In keeping with our expeditionary nature, these installations that support the MEFs are strategically located near air and sea ports of embarkation and are serviced by major truck routes and rail heads to allow for the rapid and efficient movement of Marines and equipment.

1006. Headquarters, U.S. Marine Corps

Headquarters, U.S. Marine Corps, consists of the Commandant of the Marine Corps and those staff agencies that advise and assist the Commandant in discharging those responsibilities prescribed by law and higher authority. The internal organization of Headquarters, U.S. Marine Corps is described in the *Headquarters Marine Corps Organization Manual*.

The Commandant of the Marine Corps is directly responsible to the Secretary of the Navy for the administration, discipline, internal organization, training, requirements, efficiency, and readiness of the Marine Corps; the operation of the Marine Corps materiel support system; and the total performance of the Marine Corps.

Chapter 2

Marine Air-Ground Task Forces

2001. General

The MAGTF is the Marine Corps' principle organization for the conduct of all missions across the range of military operations. MAGTFs are balanced, combined-arms forces with organic ground, aviation, and sustainment elements. They are flexible, task-organized forces that can respond rapidly to a contingency anywhere in the world and are able to conduct a variety of missions. Although organized and equipped to participate as part of naval expeditionary forces, MAGTFs also have the capability to conduct sustained operations ashore. The MAGTF provides a combatant commander or other operational commander with a versatile expeditionary force that is capable of responding to a broad range of crisis and conflict situations. MAGTFs are organized, trained, and equipped to perform missions ranging from humanitarian assistance to peacekeeping to intense combat and can operate in permissive, uncertain, and hostile environments. They may be shore- or sea-based in support of joint and multinational major operations and/or campaigns. MAGTFs deploy as amphibious, air-contingency, or maritime prepositioning forces (MPFs), either as part of a naval expeditionary force or via strategic lift. They can present a minimal or a highly visible presence and are able to project combat power ashore in measured degrees or can provide secure staging areas ashore for follow-on forces. MAGTFs are prepared for immediate deployment overseas into austere operating environments, bringing all means necessary to accomplish the mission. When deployed aboard amphibious shipping, MAGTFs maintain a continuous presence at strategic locations around the globe and can be rapidly moved to and indefinitely stationed at the scene of potential trouble. The MAGTF provides the JFC with the capability of reconstitution, which is the ability of an expeditionary force to regenerate, reorganize, replenish, and reorient itself for a new mission without having to return to its home base.

MAGTF operations are built on a foundation of six special core competencies: expeditionary readiness,

combined-arms operations, expeditionary operations, seabased operations, forcible entry from the sea, and Reserve integration.

To carry out their mission, MARFOR must be—

- w Organized, trained, and equipped for combat essential to the prosecution of a naval campaign to seize objectives against the best and most modern equipped enemy.
- w A balanced force of combined arms and services.
- w Primarily trained, organized, and equipped for offensive employment.
- w Adaptable to the active defense of advanced naval bases.
- w Trained, equipped, and ready for prompt and effective employment in any climate or terrain.
- w Trained and equipped for airborne operations as required, in accordance with policies and doctrines of the JCS.
- w Provided with sufficient organic CSS capability to establish and sustain combat power in the execution of normal missions and capable of supporting—
 - { Supply.
 - { Maintenance.
 - { Transportation.
 - { Deliberate engineering.
 - { Services.
 - { Health services.
- w Provided with organic aviation units primarily organized, trained, and equipped to operate in conjunction with ground units in amphibious operations and capable of performing—
 - { Offensive air support (OAS).

- { Anti-air warfare (AW).
- { Assault support.
- { Air reconnaissance.
- { Electronic warfare (EW).
- { Control of aircraft and missiles.

Although MAGTFs are task organized, each MAGTF, regardless of its size or mission, has the same basic structure. Each MAGTF has four core elements: a CE, a ground combat element (GCE), an aviation combat element (ACE), and a CSS element (CSSE). (See figure 2-1.)

The CE is the MAGTF headquarters. It is task organized to provide command and control capabilities (including intelligence and communications) necessary for effective planning, direction, and execution of all operations.

The GCE is task organized to conduct ground operations in support of the MAGTF mission. It is normally formed around an infantry organization reinforced with requisite artillery, reconnaissance, armor, and engineer forces and can vary in size and composition from a rifle platoon to one or more Marine divisions.

The ACE is task-organized to support the MAGTF mission by performing some or all of the six functions of Marine aviation. The ACE is normally built around an aviation

organization that is augmented with appropriate air command and control, combat, combat support, and CSS units. The ACE can operate effectively from ships, expeditionary airfields, or austere forward operating sites and can readily and routinely transition between sea bases and expeditionary airfields without loss of capability. The ACE can vary in size and composition from an aviation detachment with specific capabilities to one or more MAWs.

The CSSE is task organized to provide the full range of CSS functions and capabilities needed to support the continued readiness and sustainability of the MAGTF as a whole. It is formed around a CSS headquarters and may vary in size and composition from a support detachment to one or more Marine FSSG.

2002. Marine Expeditionary Force

The MEF is the principal Marine Corps warfighting organization. It is capable of missions across the range of military operations, through amphibious assault and sustained operations ashore in any environment. With appropriate augmentation, the MEF CE is capable of performing as a JTF headquarters.

a. Organization

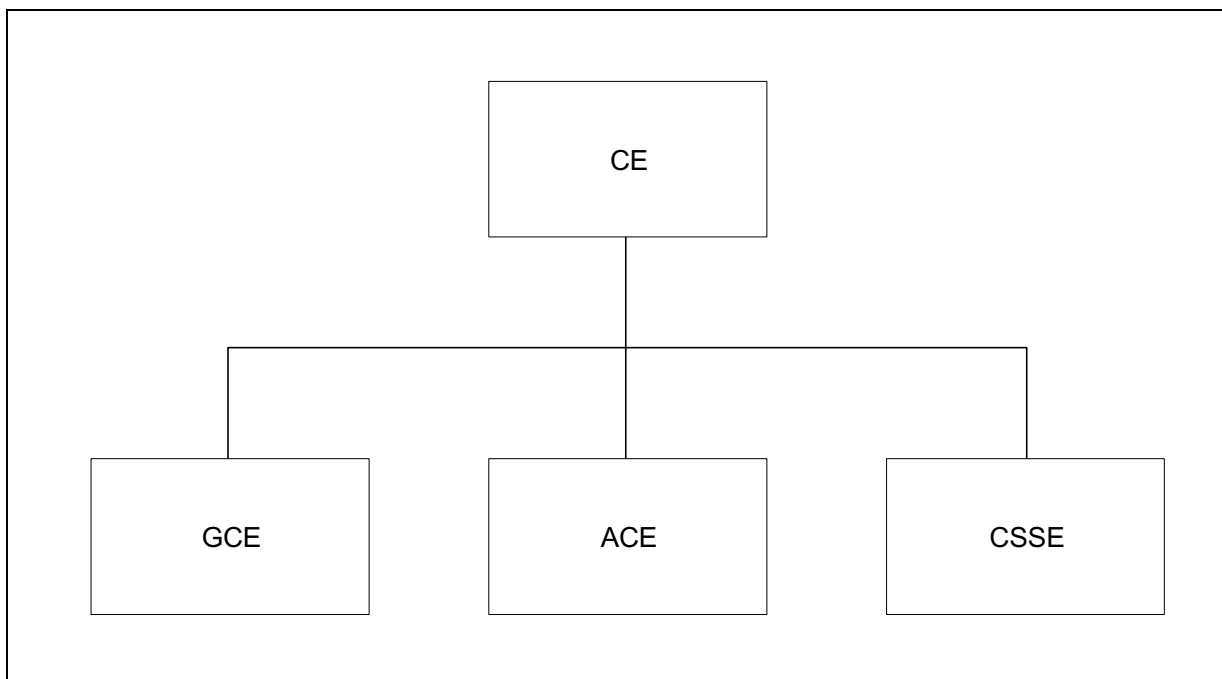

Figure 2-1. MAGTF Organization.

There are three standing MEFs: I Marine expeditionary force (I MEF), based in southern California and Arizona; II Marine expeditionary force (II MEF), based in North and South Carolina; and III Marine Expeditionary Force (III MEF), based in Japan and Hawaii. Each standing MEF consists of a permanent CE and one Marine division, MAW, and FSSG. (See figure 2-2.) These major commands constitute the primary reservoir of combat capabilities from which MAGTFs are sourced.

b. Concept of Employment

The size and composition of a deployed MEF can vary greatly depending on the requirements of the mission. It can deploy with not only its own units but also units from the other standing MEFs, the Marine Corps Reserve, or the other Services and the Special Operations Command. A MEF typically deploys by echelon with 60 days of sustainment. The lead echelon of the MEF, tailored to meet the specific mission, is designated the MEF (forward) (MEF(FWD)) and may be commanded by the MEF commander personally or by a designated commander. The

MEF(FWD) prepares for the subsequent arrival of the rest of the MEF or other joint or combined forces. However, the deployment of the MEF(FWD) does not necessarily mean that all the forces of the standing MEF will follow. This would occur only if the entire MEF were required. MEFs may conduct sustained operations ashore upon completion of an amphibious operation or by deploying from the sea, land, or air and linking up with maritime prepositioning ships carrying equipment and supplies. For additional information concerning MPF operations refer to Marine Corps warfighting publication (MCWP) 3-32, *Maritime Prepositioning Force Operations* (draft).

2003. Marine Expeditionary Unit (Special Operations Capable)

The Marine expeditionary unit (special operations capable (MEU (SOC))) is the standard forward-deployed Marine expeditionary organization. (See figure 2-3.) Marine Corps Forces Atlantic and Pacific maintain forward-deployed MEUs (SOC) in the Mediterranean Sea, the western Pacific, and the Indian Ocean or Arabian Gulf region. The MEU (SOC) can be thought of both as a self-contained

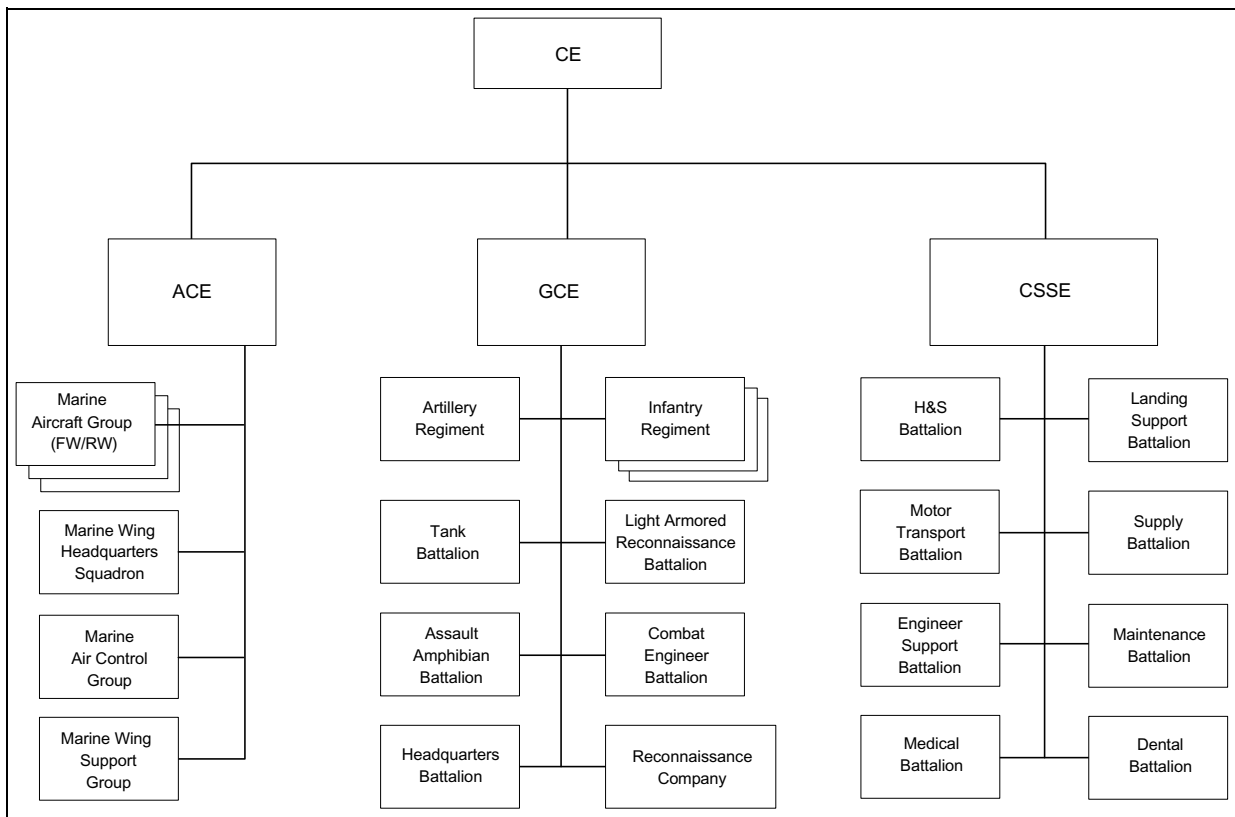

Figure 2-2. Example of a MEF.

operating force capable of missions of limited scope and duration and as a forward-deployed extension of the Marine expeditionary force.

MEUs routinely receive special training before deploying that results in their being designated as “special operations capable.” To receive the certification, the MEU undergoes an intensive 26-week, standardized predeployment training program that includes an exercise and a final evaluation. The MEU must demonstrate competence across the entire spectrum of required capabilities, be able to plan and execute any assigned mission within six hours of notification, and conduct multiple missions simultaneously. These MEUs are augmented with selected personnel and equipment to provide enhanced conventional and selected maritime special operations capabilities.

a. Organization

There are seven standing MEU (SOC) CEs. Residing within I MEF are the 11th, 13th, and 15th MEUs (SOC); residing within II MEF are the 22nd, 24th, and 26th MEUs (SOC); residing within III MEF is the 31st MEU (SOC).

Although each MEU (SOC) is task organized, a typical MEU (SOC) includes—

- w A standing CE.
- w An infantry battalion reinforced with artillery, reconnaissance, engineer, armor, assault amphibian units, and other detachments as required.
- w A reinforced helicopter squadron with transport, utility, and attack helicopters, a detachment of vertical/short takeoff and landing (V/STOL)

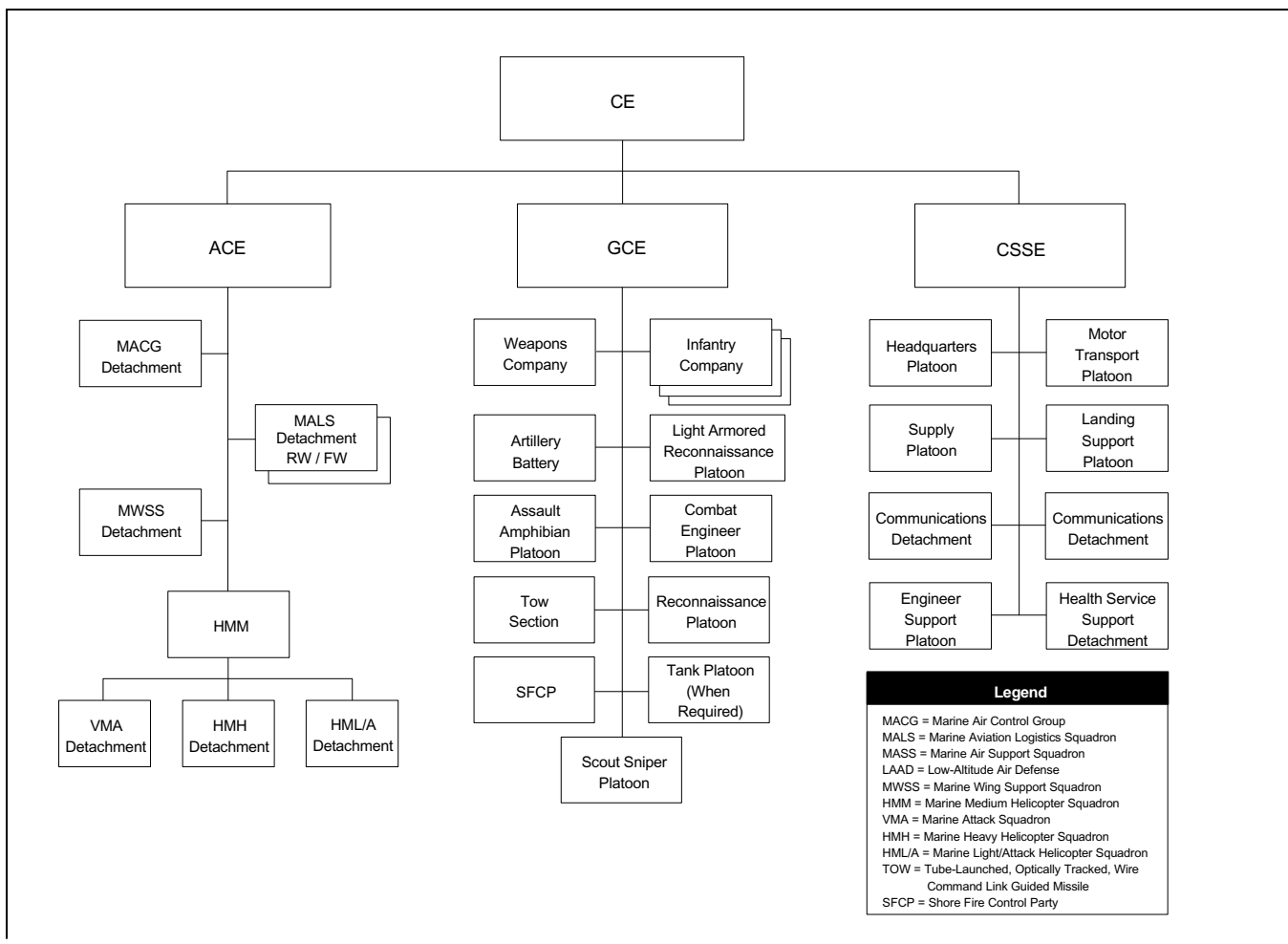

Figure 2-3. Example of a MEU (SOC).

fixed-wing attack aircraft, and other detachments as required.

- w A task-organized CSSE.
- w Sustainment for 15 days.

b. Concept of Employment

Embarked aboard a Navy amphibious ready group (ARG), a deployed MEU (SOC) provides a combatant commander or other operational commander with a quick, sea-based reaction force for a wide variety of situations. In many cases, the MEU (SOC) embarked on amphibious shipping may be the first U.S. force at the scene of a crisis and can conduct enabling actions for larger follow-on forces. It can provide a visible and credible presence in many potential trouble spots and can demonstrate the United States' willingness to protect its interests overseas.

The MEU(SOC) mission is to provide the NCA and the combatant commanders with a forward deployed, sea-based, rapid crisis response capability to execute a full range of military operations. It is organized, trained, and equipped as a self-sustaining, general-purpose expeditionary MAGTF that possesses the capability to conduct operations across the spectrum of conflict, from military operations other than war, to amphibious and other conventional operations in support of various contingency requirements, including selected maritime special operations such as—

- w Reconnaissance and surveillance.
- w Specialized demolitions.
- w Tactical recovery of aircraft and personnel (TRAP).
- w Seizure/recovery of offshore energy facilities.
- w Seizure/recovery of selected personnel or material.
- w Visit, board, search, and seizure of vessels.
- w In-extremis hostage recovery.

2004. Special Purpose Marine Air-Ground Task Force

A special-purpose MAGTF (SPMAGTF) is a nonstanding MAGTF temporarily formed to conduct a specific mission. It is normally formed when a standing MAGTF is either inappropriate or unavailable. SPMAGTFs are organized, trained, and equipped to conduct a wide variety of missions ranging from crisis response, to regionally focused training exercises, to peacetime missions. Their SPMAGTF designation derives from the mission they are assigned, the location in which they will operate, or the name of the exercise in which they will participate (e.g., "SPMAGTF (X)," "SPMAGTF Somalia," "SPMAGTF UNITAS," "SPMAGTF Andrew," etc.).

a. Organization

An SPMAGTF may be any size, but normally it is the size of a MEU (or smaller) with narrowly focused capabilities chosen to accomplish a particular mission. It may be task organized deliberately from the assets of a standing MEF, or may be formed on a contingency basis from an already-deployed MAGTF to perform an independent, rapid-response mission of limited scope and duration. By definition, SPMAGTFs include all four of the basic elements of a MAGTF.

b. Concept of Employment

SPMAGTFs are generally employed in the same manner as a MEU. However, under certain circumstances they may be deployed via commercial shipping or aircraft, strategic airlift, or organic Marine aviation.

Chapter 3

Marine Aircraft Wings

Section I. Fundamentals

3101. General

The primary mission of Marine Corps aviation is to participate as the air component of the MAGTF in the seizure and defense of advance naval bases and to conduct such land operations as may be essential for the prosecution of a naval campaign. A collateral mission is to participate as an integral component of naval aviation in the execution of such other Navy functions as the fleet commanders so direct.

3102. Expeditionary Aspects

Marine Corps aviation is organized, trained, and equipped to function as the MAGTF ACE. The ACE must be prepared to operate from a variety of sea- and shore-based facilities (from naval shipping to austere forward operating bases (FOBs)) to support MAGTF expeditionary operations. The focus of the ACE is to support the MAGTF during the assault landing and subsequent operations ashore. Initially, support could be furnished by Marine aircraft squadrons operating from FOBs within striking distance of the amphibious objective area or by V/STOL aircraft operating from amphibious shipping.

3103. Functions

MAGTF aviation tasks are divided into six functional areas that guide the commander in planning aviation allocation and employment. The commander considers the functional area to be used, rather than the specific means (individual weapons system), for accomplishing the mission. Individual weapons systems perform missions that are part of each function of Marine aviation. The six functions of Marine aviation are described in the following paragraphs.

a. OAS

OAS is “those air operations conducted against enemy installations, facilities, and personnel to directly assist the attainment of MAGTF objectives by the destruction of enemy resources or the isolation of his military force.” (MCRP 5-12C, *Marine Corps Supplement to the DOD Dictionary of Military and Associated Terms*). OAS includes the categories of close air support (CAS) and deep air support (DAS).

(1) CAS. CAS is “air action by fixed- and rotary-wing aircraft against hostile targets which are in close proximity to friendly forces and which require detailed integration of each air mission with the fire and movement of those forces.” (Joint Pub 1-02, *DOD Dictionary of Military and Associated Terms*)

(2) DAS. DAS is “air action against enemy targets at such a distance from friendly forces that detailed integration of each mission with fire and movement of friendly forces is not required. Deep air support missions are flown on either side of the fire support coordination line; the lack of a requirement for close coordination with the fire and movement of friendly forces is the qualifying factor.” (MCRP 5-12C). DAS missions include strike coordination, air interdiction, and armed reconnaissance.

b. Antiair Warfare

AAW is “that action required to destroy or reduce to an acceptable level the enemy air and missile threat. It includes such measures as the use of interceptors, bombers, anti-aircraft guns, surface-to-air and air-to-air missiles, electronic attack, and destruction of the air or missile threat both before and after it is launched. Other measures which are taken to minimize the effects of hostile air action are cover, concealment, dispersion, deception (including electronic), and mobility.” (Joint Pub 1-02) The primary purpose of AAW is to gain and maintain some degree of air superiority.

AAW includes both offensive and defensive means to accomplish its objective.

(1) Offensive AAW. Offensive AAW constitutes operations conducted against the enemy air or air defense system before it can be launched or assume an attacking role. Offensive AAW operations in or near the objective area consist mainly of air attacks to destroy or neutralize hostile aircraft, airfields, radars, air defense systems, and supporting areas. Offensive AAW includes theater missile defense (TMD) attack operations and suppression of enemy air defense operations.

(2) Air Defense. Air defense includes all defensive measures designed to destroy attacking enemy aircraft or missiles in the earth's atmosphere or to nullify or reduce the effectiveness of such attack. There are two forms of air defense: active and passive.

(a) Active air defense is direct defensive action taken to destroy attacking enemy aircraft or missiles or to nullify or reduce the effectiveness of such an attack. Active air defense includes the use of aircraft, air defense weapons, supporting weapons (weapons not typically used in an air defense role), and EW.

(b) Passive air defense constitutes all measures, other than active defense, taken to minimize the effects of hostile air action. These include the use of cover, concealment, camouflage, deception, dispersion, electronic protection, and protective construction. Passive air defense is a command responsibility of every unit commander.

c. Assault Support

Assault support is "the use of aircraft to provide tactical mobility and logistic support for the MAGTF, the movement of high priority cargo and personnel within the immediate area of operations, in-flight refueling, and the evacuation of personnel and cargo." (Fleet Marine Force manual (FMFM) 5-30, *Assault Support*) The tasks of assault support fall within the following seven categories:

(1) Combat assault transport provides mobility and logistic support to the MAGTF. It can be used to rapidly deploy forces, bypass obstacles, or redeploy forces to meet the enemy threat, thus allowing for a rapid buildup of combat power at a specific time and location.

(2) Aerial delivery operations transport equipment and supplies to FOBs or remote areas either by landing at the desired location or through air drop.

(3) Aerial refueling allows MAGTF aircraft to conduct flight-ferrying operations, extend time on station, and extend mission range. In addition, aerial refueling aids in the recovery of damaged or low-fuel aircraft by extending their time in the air, when required.

(4) Air evacuation provides transportation of personnel and equipment from FOBs or remote areas by using transport helicopters and fixed-wing aircraft.

(5) TRAP facilitates the recovery of personnel and equipment while preventing additional loss. The TRAP mission is an implied task associated with all MAGTF operations. Specially briefed aircrews are assigned to perform TRAP missions. TRAP missions are conducted when the tactical situation prevents the use of traditional search and reserve techniques. TRAP is normally conducted only when survivors and their locations are confirmed.

(6) Air logistical support operations are conducted by using fixed-wing aircraft to provide assault support of MAGTF forces on the ground in much the same manner as helicopters. Air logistical support delivers troops, equipment, and supplies to areas beyond helicopter range and lift capability or when surface transportation is slow or unavailable.

(7) Battlespace illumination can be provided by both fixed- and rotary-wing aircraft and is used to provide light in the battlespace area.

d. Air Reconnaissance

Air reconnaissance is "the acquisition of intelligence information by employing visual observation and/or sensors in air vehicles." (FMFM 5-10, *Air Reconnaissance*)

(1) Visual Reconnaissance. Any airborne platform may conduct visual aerial reconnaissance operations. An observer or pilot can visually search a route, point, or area. Visual aerial reconnaissance is frequently related to offensive action such as artillery, naval surface fires (NSF), or air support.

(2) Multisensor Imagery Reconnaissance.

Multisensor imagery reconnaissance includes photographic, side-looking airborne radar, and infrared reconnaissance

techniques. When the imagery is processed, it provides intelligence information to all interested commands.

(3) Electronic Reconnaissance. EW-configured aircraft provide the means to detect, identify, evaluate, and locate foreign electromagnetic radiation that is emanating from other-than-nuclear detonations or radioactive sources, thereby providing up-to-date electronic order of battle and technical intelligence.

e. EW

EW is “any military action involving the use of electromagnetic and directed energy to control the electromagnetic spectrum or to attack the enemy.” (Joint Pub 1-02) The three major subdivisions of EW are electronic attack (EA), electronic protection, and EW sup- port.

(1) EA is “that division of electronic warfare involving the use of electromagnetic, directed energy, or antiradiation weapons to attack personnel, facilities, or equipment with the intent of degrading, neutralizing, or destroying enemy combat capability.” (Joint Pub 1-02)

(2) Electronic protection involves “actions taken to protect personnel, facilities, and equipment from any effects of friendly or enemy employment of electronic warfare that degrade, neutralize, or destroy friendly combat capability.” (Joint Pub 1-02)

(3) EW support involves “actions tasked by, or under direct control of, an operational commander to search for, intercept, identify, and locate sources of intentional and unintentional radiated electromagnetic energy for the purpose of immediate threat recognition.” (Joint Pub 1-02)

f. Control of Aircraft and Missiles

The control of aircraft and missiles involves the coordinated employment of facilities, equipment, communications, procedures, and personnel that allows the ACE commander to plan, direct, and control the efforts of the ACE to support accomplishment of the MAGTF’s mission. Control of aircraft and missiles is executed through the Marine Air Command and Control System (MACCS). The control of aircraft and missiles function serves to integrate the activities of the other five functions of Marine aviation into a coordinated effort.

3104. Marine Aviation Organization

Organizationally, Marine aviation is divided into three active duty MAWs and one Reserve MAW. Each MAW has a unique organizational structure; these structures are represented in figure 3-1 on page 3-4, figure 3-2 on page 3-5, figure 3-3 on page 3-6, and figure 3-4 on page 3-7. The MAW provides the personnel and equipment for the MAGTF ACE. Operationally, the ACE task organizes with various resources from the MAW that are necessary to complete the ACE’s assigned mission.

Typically, the ACE supports a MEF with one or more MAWs. Support to the MEF may include assets from more than one MAW that are task organized to form a MAW (reinforced). The ACE supports a MEU with a task-organized squadron that usually consists of a mix of rotary-wing aircraft, short take-off and landing aircraft, a Marine air control group (MACG) detachment, a fixed-wing Marine aviation logistics squadron (MALS) detachment, and a rotary-wing MALS detachment. The ACE normally supports an SPMAGTF with a task-organized squadron that consists of a mix of rotary-wing aircraft, short take-off and landing aircraft, a MACG detachment, a fixed-wing MALS detachment, and a rotary-wing MALS detachment. Actual squadron composition will depend on mission requirements.

MAWs include Marine aircraft, air control, and wing support groups. Each group includes the squadrons and/or battalions that are necessary to complete the groups’ roles in Marine aviation. MAWs and groups are not organized according to tables of organization (T/Os), but rather are task organized to accomplish the missions assigned. Each of the four wings may have a different organization; however, each wing is capable of performing all six functions of Marine aviation.

3201. General

The notional MAW is task organized to provide a flexible and balanced aviation organization that is capable of providing the full range of aviation operations in a variety of areas without the requirement for prepositioned support, control, and logistical facilities. The MAW is the smallest unit with the inherent capability of performing all six functions of Marine aviation. The wing is composed of the subordinate units depicted in figure 3-5. Aviation organizations smaller than a wing can provide the capabilities to accomplish any or all aviation functions by using task organization.

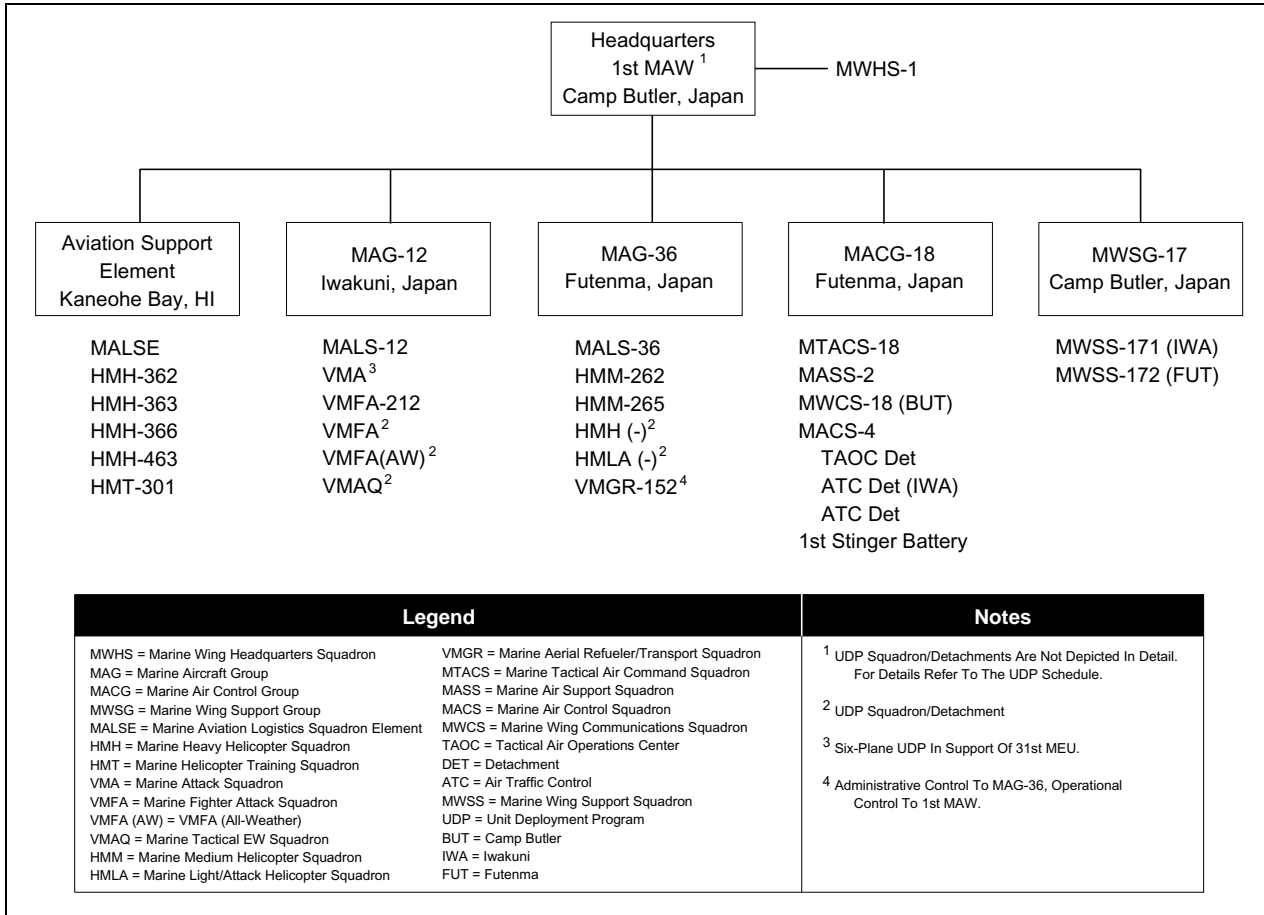

Figure 3-1. 1st MAW.

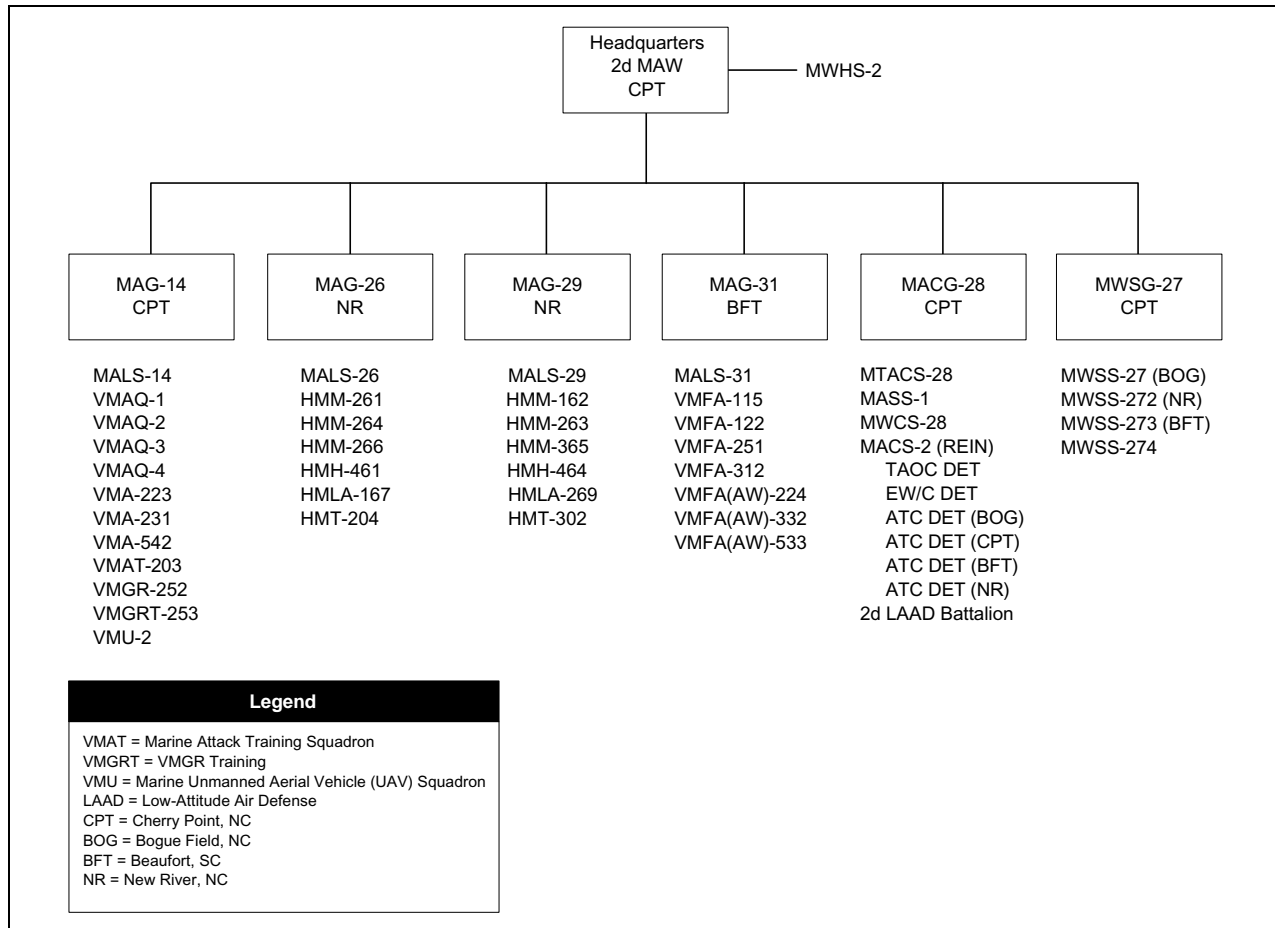

Figure 3-2. 2d MAW.

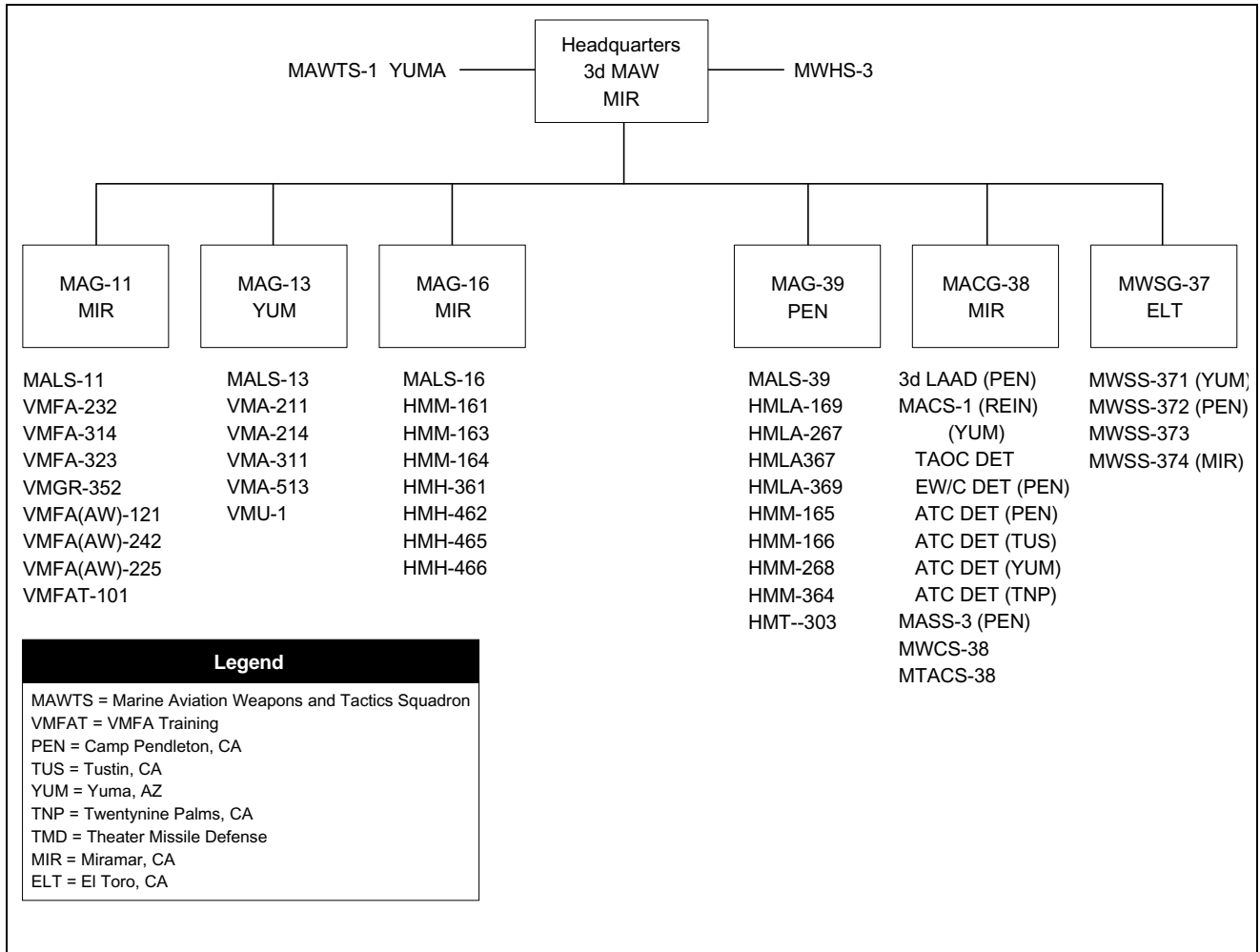

Figure 3-3. 3d MAW.

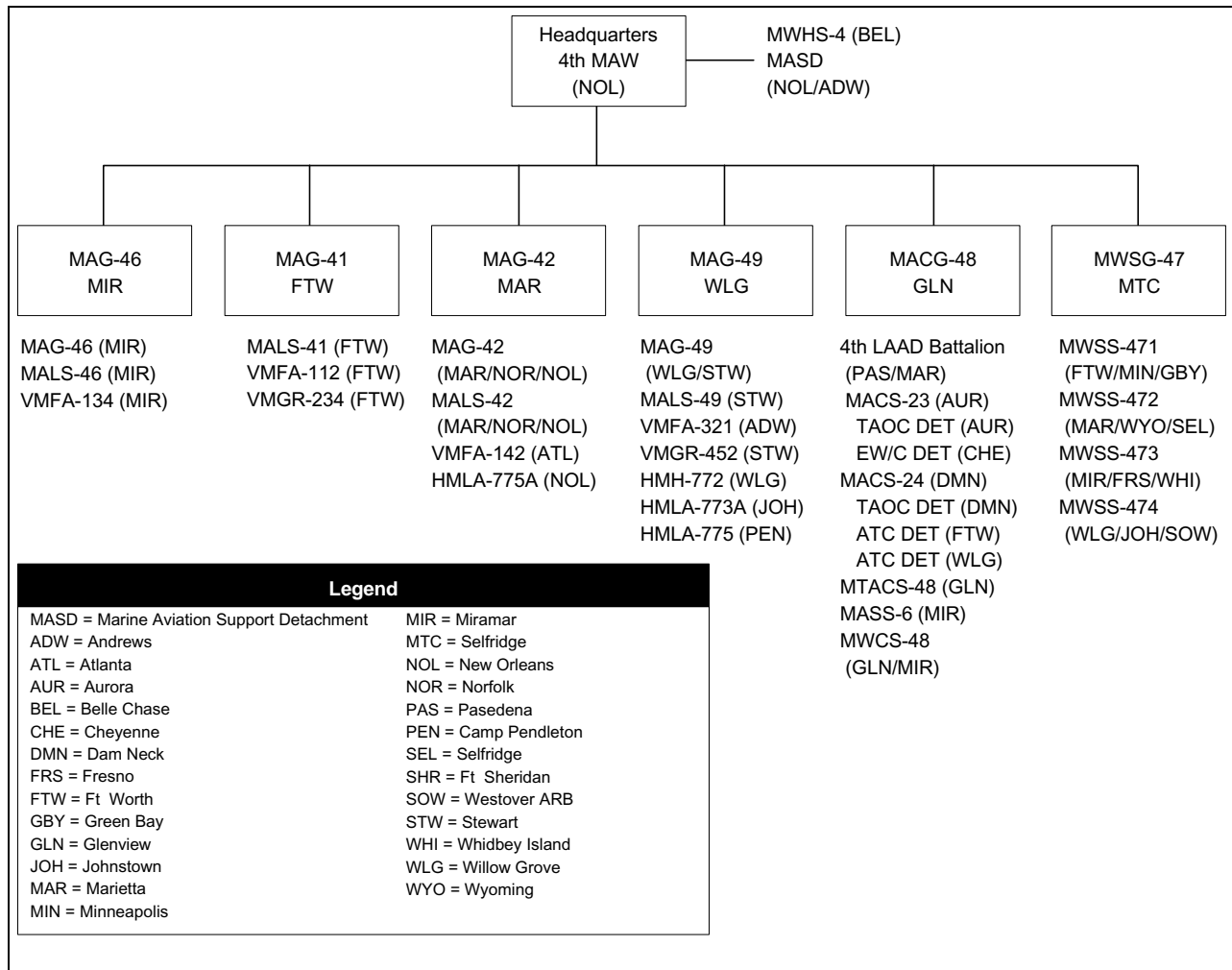

Figure 3-4. 4th MAW.

Section II. Marine Aircraft Wing

3202. Marine Wing Headquarters Squadron (MWHS)

a. Mission

The MWHS provides command, administrative, and supply support for a MAW headquarters and certain elements of the MACG.

b. Tasks

- w Provide camp facilities and services, including food service, for all elements of the Marine wing

headquarters and for the Marine tactical air command squadron (MTACS) and Marine wing communications squadron (MWCS) of the MACG.

- w Maintain the capability of deploying as an integral unit when augmented with maintenance support personnel.
- w Provide detachments for supported units as required.
- w Provide for internal security of the MAW headquarters.

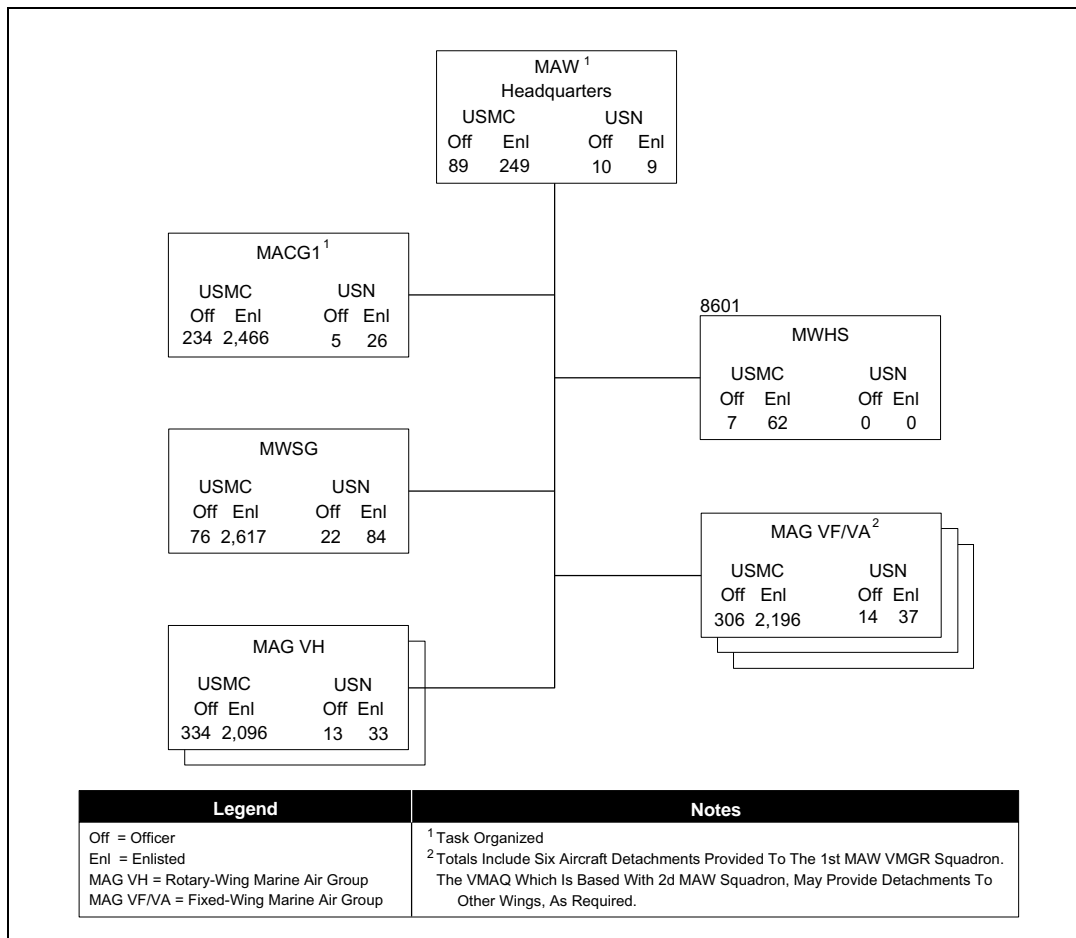

Figure 3-5. Notional MAW.

c. Concept of Organization

This organization will normally function as an integral unit. It is structured to operate as a subordinate unit of the MAW to support the units mentioned above.

d. Concept of Employment

The MWHS provides support for wing headquarters and certain elements of the MACG.

e. Administrative Capability

The MWHS is capable of self-administration.

f. Logistic Capabilities

(1) Maintenance. The MWHS is capable of organizational (1st echelon) maintenance on all assigned equipment and organizational (2d echelon) maintenance on organic infantry weapons. Organizational maintenance (2d echelon) on motor transport and engineer equipment is provided by the Marine wing support group (MWSG). Organizational (2d echelon) maintenance support for communications equipment is provided by the MWCS.

(2) Supply. The MWHS is capable of organic supply functions.

(3) Medical. The MWHS is capable of providing routine and emergency medical support for all elements of the wing headquarters.

(4) Transportation. The MWHS has no logistic transportation capabilities; support is provided by the MWSG.

(5) Messing. The MWHS provides food service support for all elements of the wing headquarters, MTACS, and MWCS.

(6) Selected Items of Equipment. For selected items of equipment, see table 3-1.

3301. General

The mission of the MACG is to provide, operate, and maintain the MACCS. The MACG contains subordinate units that provide the major facilities of the MACCS. It normally consists of a MTACS, a Marine air support squadron (MASS), one Marine air control squadron (MACS), a low-altitude air defense (LAAD) battalion, and an MWCS. (See figure 3-6.)

The tactical air command center (TACC), furnished by the MTACS, is the principal air command agency. The major air control agencies are the tactical air operations center (TAOC) and Marine air traffic control (ATC) detachments

TAM Number	Item	Quantity
A0662	FMF downsized end-user computer equipment	19
A0870	Intermediate suite, IAS, AN/UYQ69(V)2	1
A0885	Control system, command global, M61	3
A1011	Marine CSS Command and Control System	24
A2534	Tactical Combat Operations (TCO) System	4
E09893	Machine gun, medium, 7.62 mm, M240G	12

Table 3-1. Selected Items of Equipment for the MWHS.

Section III. Marine Air Control Group

(MATCDs), which are furnished by the MACS, and a direct air support center (DASC), which is furnished by the MASS. The MAGTF's organic surface-to-air weapons are provided by the LAAD bat- talion.

3302. Marine Air Control Group Head- quarters

a. Mission

MACG headquarters coordinates all aspects of air command and control and air defense within the MAW. It provides the command and staff functions for the MACG commander when deployed as part of the MAGTF ACE.

b. Tasks

- w Provide the CE of the MACG or MACG detach- ment for the MAGTF ACE.
- w Plan and coordinate the operations, maintenance, and supply of the MACCS.
- w Plan and coordinate the air defense operations of the MAGTF.
- w Coordinate with appropriate commands to plan for the deployment and employment of the MACG and its separately deployable detachments as the MACCS of an ACE.
- w Coordinate with other U.S. Services and allies for planning and conducting MAGTF air operations in joint and multinational force operations.

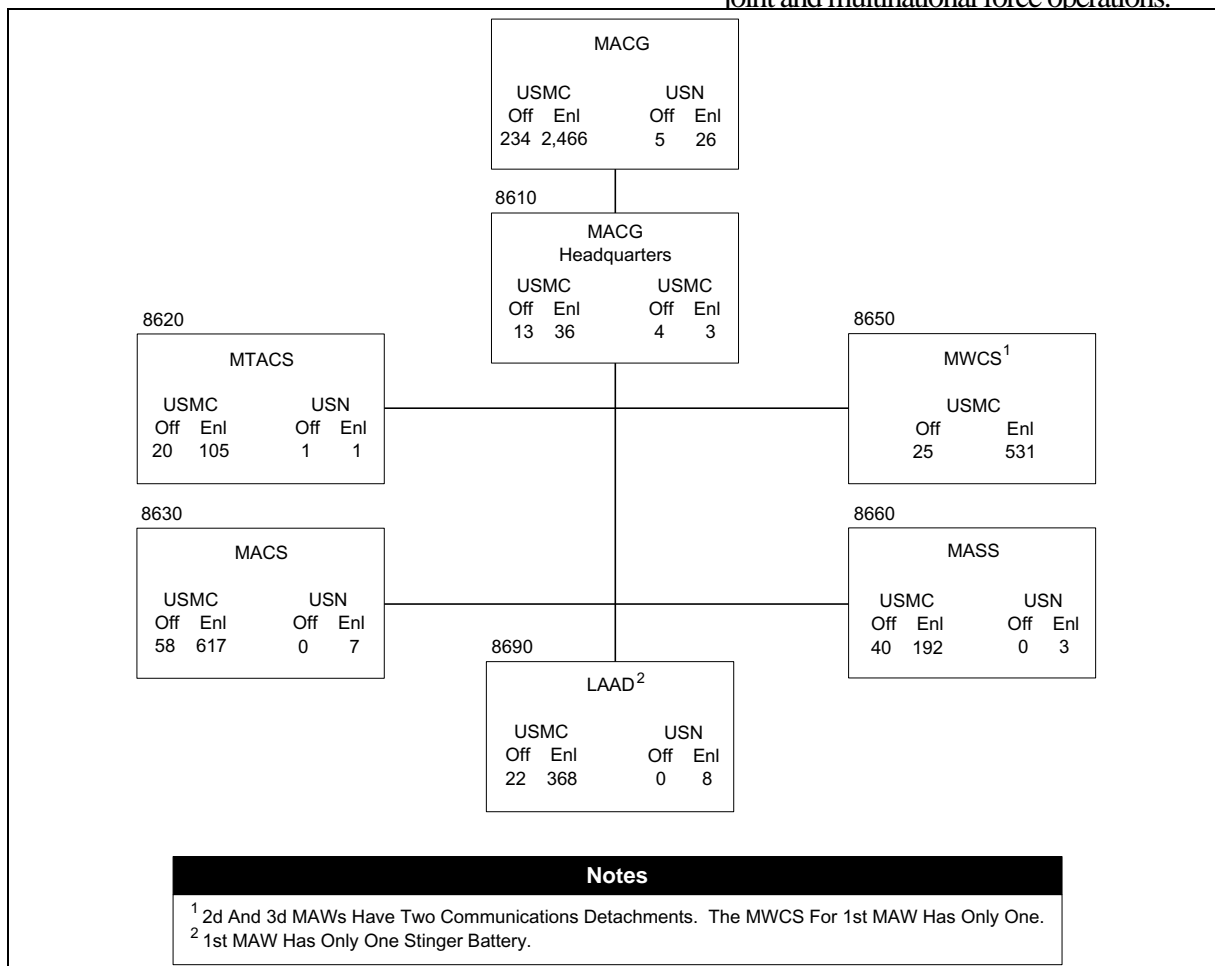

Figure 3-6. Marine Air Control Group.

- w Advise the ACE commander on applicable matters pertaining to the employment of agencies comprising the MACCS.
- w Perform command and staff functions associated with fulfilling the MACG's mission.
- w Conduct operations while in a nuclear, biological, and chemical (NBC) and/or EW environment.
- w Maintain the capability for deploying independent units.

c. Concept of Organization

The MACG headquarters is organized to accomplish the command and staff functions necessary to fulfill the MACG's mission in support of the MAW and MAGTF ACE.

d. Concept of Employment

The MACG headquarters is employed with the combined assets of the MACG as a component of the ACE; normally at the MEF or MEF(FWD) element level. Before establishment of a MEF, in conjunction with MAGTF task organization, specific MACG headquarters personnel may be required to augment the MTACS. For additional information on MACCS employment, see MCWP 3-25.3, *Marine Air Command and Control System Handbook*.

e. Administrative Capabilities

The MACG headquarters is capable of self-administration.

f. Logistic Capabilities

- (1) Maintenance.** All maintenance support is provided by the associated MTACS.
- (2) Supply.** All supply support is provided by the associated MTACS.
- (3) Transportation.** All motor transport is provided by the associated MTACS.
- (4) Medical.** Medical personnel assigned to the MACG headquarters medical department are provided to perform administrative functions and to coordinate, oversee, and

augment the actions of those medical personnel who are assigned to subordinate units of the MACG. Routine and emergency medical support will be provided by the medical personnel who are organic to the associated MTACS.

- (5) Messing.** All food service support is provided by the MWHS.

3303. Marine Tactical Air Command Squadron

a. Mission

The MTACS provides equipment, maintenance, and operations for the TACC of the ACE as a component of the MAGTF. It equips, mans, operates, and maintains the current operations section of the TACC. It also provides and maintains a facility for the TACC future operations and future planning sections and installs and maintains associated automated systems.

b. Tasks

- w Provide the operational command post (CP) for the ACE commander of a MEF or the forward element of a MEF.
- w Assist in coordinating air operations to meet the operational requirements of the MEF.
- w Assist in planning air operations.
- w Maintain the capability to accomplish TACC functions while displacing.
- w Conduct operations while in an NBC and/or EW environment.
- w Assist in coordinating with other U.S. Services and allies for the conduct of MAGTF air operations in joint and multinational force operations.
- w Perform command and staff functions associated with fulfilling the MTACS mission.
- w Coordinate with the appropriate commands to plan for the deployment and employment of the squadron.

- w Provide logistical and supply support for the MACG headquarters.

c. Concept of Organization

The MTACS is organic to the MACG of the MAW.

d. Concept of Employment

The MTACS is employed as an element of the MACG by providing the TACC, which is the senior agency of the MACCS. MTACS can furnish a TACC capability of varying sizes to meet operational needs and the capabilities required by the ACE and MAGTF commanders. The TACC battlestaff requires personnel augmentation from the MACG headquarters and the ACE to provide operations and planning functions. For additional information on the TACC, see MCWP 3-25.4, *Tactical Air Command Center Handbook*.

e. Administrative Capabilities

The MTACS is capable of self-administration.

f. Logistic Capabilities

(1) Maintenance. The MTACS is capable of organizational (1st echelon) maintenance on all equipment; organizational (2d echelon) maintenance on motor transport equipment, ground-common high-frequency (HF) radios, and infantry weapons; intermediate (3d echelon) maintenance on electrical systems of mobile electric power generators, air conditioning equipment, and ground-common communications-electronics equipment except HF radios and switchboards; and intermediate (3d and 4th echelon) maintenance on aviation-peculiar critical low-density secondary repairables and end items.

(2) Supply. The MTACS is capable of performing supply and fiscal functions that are required for squadron and MACG headquarters operations and managing secondary repairable floats for critical low-density aviation-peculiar equipment.

(3) Transportation. The MTACS possesses sufficient motor transport equipment to support operations once the TACC is emplaced. It requires external support for equipment deployment, echelon displacement, materiel handling, and motor transport retrieval.

(4) Medical. The MTACS is capable of providing routine and emergency medical support required to meet squadron and associated MACG headquarters needs by using organic Navy corpsmen.

(5) Messing. Food service support is provided by the MWHS.

(6) Selected Items of Equipment. For selected items of equipment, see table 3-2.

3304. Marine Air Control Squadron

a. Mission

The MACS provides air surveillance and control of aircraft and surface-to-air weapons for AAW; continuous all-weather radar and nonradar ATC services and airspace management in support of a MAGTF.

b. Tasks

- w Perform command and staff functions associated with fulfilling the MACS mission.
- w Coordinate with appropriate commands to plan for the deployment and employment of the squadron and its separately deployable detachments.
- w Provide deployable detachments that are capable of air surveillance, airspace management, and control of aircraft and SAMs for AAW in support of the MAGTF.
- w Provide deployable detachments that are capable of providing ATC services at existing or expeditionary airfields and remote area landing sites.
- w When reinforced with a TMD detachment, provide SAM fires in assigned zones in defense of vital areas and installations therein against theater missile attack, and be prepared to engage surviving fixed-wing aircraft and helicopter threats.
- w Serve as the operational point of contact between the MACCS and national/international ATC agencies.

c. Concept of Organization

Table 3-2. Selected Items of Equipment for the MTACS.

TAM Number	Item	Quantity
A0012	Contingency Theater Automated Planning System	1
A0013	Operations central, AN/TYQ-51	1
A0625	Emulator unit, data link, SM822/GYQ	1
A0662	FMF downsized end-user computer equipment	17
A1115	Operations group (TACC), AN/TYA1	1
A2534	Tactical Combat Operations (TCO) System	2
D1059	Truck, cargo, 5 ton, 6 x 6, M923A1	8
D1061	Truck, cargo, 5 ton, long bed, M928	6
	Multiple Source Correlation System	1

The MACS (see figure 3-7a) is comprised of a squadron headquarters, a TAOC detachment, and two ATC detachments. One MACS organization includes four TMD detachments. The TMD detachment is designed with a liftable T/O and table of equipment (T/E) that can be assigned to support any MACS with TMD assets. A reinforced MACS is shown in figure 3-7b on page 3-14.

d. Concept of Employment

The MACS is organized and equipped for employment in the ACE of a MEF. TAOC, ATC, and TMD detachments, augmented by the appropriate elements of the headquarters, may be deployed separately to provide air control, ATC, and TMD of vital areas for a task-organized MAGTF. For additional information on MACS

detachments, see MCWP 3-25.6, *Sector Antiair Warfare Coordinator Handbook*; MCWP 3-25.7, *Tactical Air Operations Center Handbook*; MCWP 3-25.8, *Marine Air Traffic Control Detachment Handbook*; and MCWP 3-25.9, *Air Defense Detachment Handbook*.

e. Administrative Capability

The MACS headquarters is capable of self-administration. The TAOC, EW/C, and ATC detachments are capable of limited self-administration.

f. Logistic Capability

(1) Maintenance. The MACS is capable of organizational (1st echelon) maintenance on all equipment;

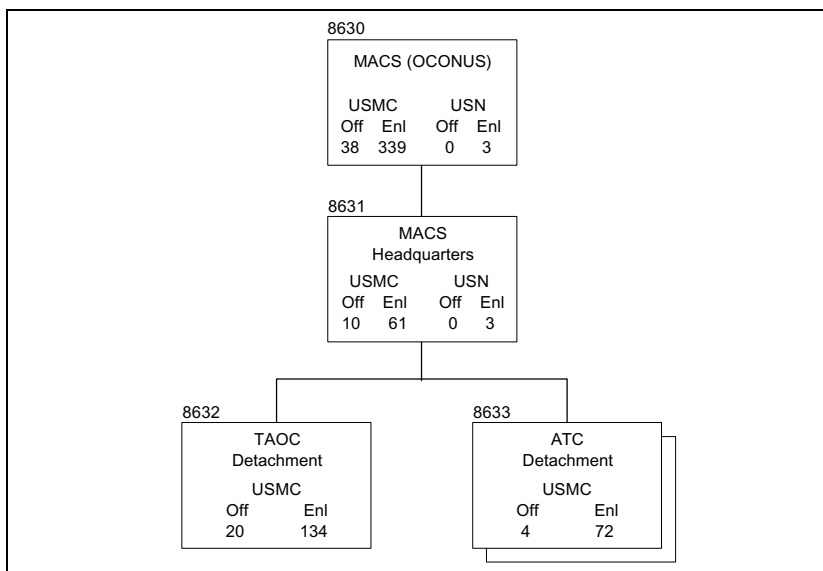

Figure 3-7a. Marine Air Control Squadron.

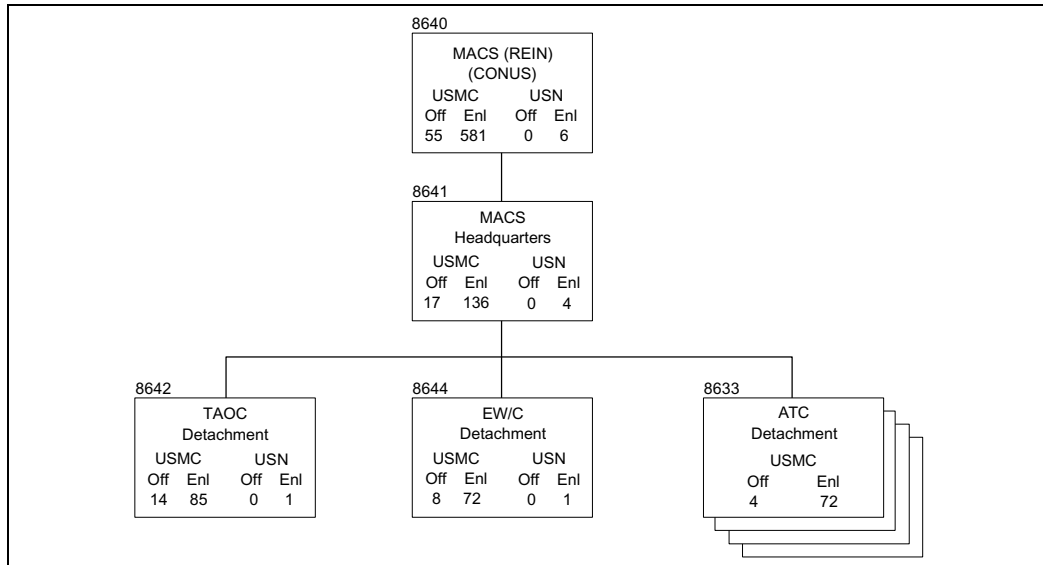

Figure 3-7b. Marine Air Control Squadron (Reinforced).

organizational (2d echelon) maintenance on motor transport equipment, ground-common HF radios, and infantry weapons; intermediate (3d echelon) maintenance on electrical systems of mobile electric power generators, refrigeration units, air conditioning equipment, and ground-common communications-electronics equipment except for HF radios; intermediate (3d and limited 4th echelon) maintenance on aviation-peculiar secondary repairables and end items; and organizational and intermediate (1st through 4th echelon) maintenance on assigned Navy-furnished equipment.

(2) Supply. The MACS is capable of performing supply and fiscal functions that are required for squadron operations and managing secondary repairable floats for aviation-peculiar equipment. The MACS requires support from a MALS for missile resupply and for performing Navy supply and fiscal functions.

(3) Transportation. The MACS possesses sufficient organic motor transport equipment to satisfy the routine administrative transportation requirements of the squadron. It requires support from an MWSG for the movement and tactical emplacement of TAOC, EW/C, and ATC detachment equipment.

(4) General Engineering. Intermediate mechanical maintenance (3d and 4th echelon) for mobile electric power generators and air conditioners is provided by the FSSG.

(5) Health Services. The MACS is capable of providing routine and emergency medical support by using organic Navy corpsmen.

(6) Messing. Food service support is provided by the MWSG or supported unit.

(7) Selected Items of Equipment. For selected items of equipment, see table 3-3.

3305. Marine Wing Communications Squadron

a. Mission

The MWCS provides expeditionary communications for the ACE of a MEF, including the phased deployment of task-organized elements thereof.

b. Tasks

- w Provide for the effective command of subordinate detachments.
- w Assist in the systems planning and engineering of ACE communications. Install, operate, and maintain expeditionary communications for command and control of the MEF ACE.
- w Provide operational systems control centers, as required, to coordinate communication functions internally and externally to the ACE.

Table 3-3. Selected Items of Equipment for the MACS.

TAM Number	Item	MACS Quantity	MACS (Rein) Quantity
A1415	Radar set, lightweight battlefield surveillance radar (LBSR), AN/PPS15A(V)2	2	4
A1500	Radar set, ATC, lightweight, AN/TPS63B	2	2
A1503	Radar set, 3D, lightweight, AN/TPS59(V)3	1	2
A2525	Tactical air operations module (TAOM), AN/TYQ23(V)1	4	6
D1059	Truck, cargo, 5 ton, 6 x 6, M923A1	14	14
D1061	Truck, cargo, 5 ton, long bed, with winch, M928	6	14
Q0945	ATC tower system, AN/TSQ-120 A/B	2	4
Q0960	TACAN, AN/TRN-44	2	4
E0989	Machine gun, medium, 7.62 mm, ground version, M240G	17	20
Q2115	Precision approach radar, AN/TPN-22 Marine remote area approach and landing	2	4

- w Provide calibration and repair facilities for all ground-common test measurement diagnostic equipment (TMDE) in the MAW.
- w Provide the digital backbone communications support for the ACE CE, FOBs, and MACCS agencies for up to two airfields per detachment.
- w Provide tactical automated switching and telephone services for the ACE CE and the TACC.
- w Provide electronic message distribution for the ACE CE, primary MACCS agencies, and tenant units.
- w Provide external single-channel radio and radio retransmission communications support for ACE operations as required.
- w Provide deployed wide area network (WAN) and deployed local area network (LAN) server support for the ACE CE and primary MACCS agencies.
- w Provide the support cryptographic site for all ground-common and MACCS-assigned communications security equipment within the ACE.
- w Plan and coordinate individual and unit training as required to qualify subordinate detachments for tactical deployment and combat operations.

- w Provide maintenance support for ground-common communications equipment in the MAW.

c. Concept of Organization

The MWCS consists of a headquarters element and one or two MWCS detachments.

d. Concept of Employment

The MWCS provides communications support for the ACE headquarters and TACC. Each MWCS detachment may be independently deployed to provide external communications for up to two airfields and four forward bases. For additional information on the MWCS, see MCWP 3-25.12, *Marine Wing Communications Squadron Handbook* (under development).

e. Administrative Capabilities

The MWCS and detachments are capable of self-administration.

f. Logistic Capabilities

(1) Maintenance. The MWCS is capable of organizational (1st echelon) maintenance on all organic equipment; organizational (2d echelon) maintenance on infantry

weapons, engineer, motor transport, and automated data processing equipment; intermediate-level (3d echelon) maintenance on communications-electronics equipment, communications security equipment, automated data processing equipment, electrical systems of mobile electric power generators, and air conditioning/refrigeration equipment; and inter-mediate-level (4th echelon) maintenance support for assigned critical low-density ground-common end items and associated secondary repairables. It is also capable of providing support cryptographic sites for all ground-common and MACCS-assigned communications security equipment within the ACE and calibration of TMDE.

(2) Supply. The MWCS is capable of performing supply and fiscal functions that are required for squadron operations and managing secondary repairable float for critical low-density ground communications-electronics equipment and associated A stocks.

(3) Transportation. The MWCS possesses sufficient organic motor transport equipment to satisfy the routine administrative requirements of the squadron. Additional transportation requirements are provided by the MWSG.

(4) Medical. Medical support is provided by the MWSG.

(5) Messing. Food service support is provided by the MWSG or the supported unit.

(6) Selected Items of Equipment. For selected items of equipment, see table 3-4.

3306. Marine Air Support Squadron

a. Mission

The MASS provides DASC capabilities for control and coordination of fixed- and rotary-wing aircraft operating in direct support of MAGTF forces.

b. Tasks

- w Provide operational planning for MAGTF air support operations.
- w Receive, coordinate, and process immediate requests for direct air support.
- w Provide equipment, facilities, and personnel for the operation of air support elements.
- w Conduct air support control as required to meet MAGTF operational requirements.
- w Maintain the ability to provide continuous control of direct air support while displacing by echelon.
- w Provide personnel and facilities for the simultaneous operation of the DASC and DASC (airborne).

Table 3-4. Selected Items of Equipment for the MWCS.

TAM Number	Item	Quantity
A0248	Central office, telephone, automatic, AN/TTC42(V)	3
A1795	Radio set, AN/GRC 193B(V)	25
A1930	Radio set, AN/MRC110A	8
A1935	Radio set, AN/MRC 138B(V)	10
A1955	Terminal set, radio, AN/MRC142	12
A1957	Radio set, AN/MRC145	8
A2069	Radio set, UHF, AN/PRC113(V)3	8
A2070	Radio set, manpack, AN/PRC119A	30
A2164	Radio set, AN/VRC83(V)2	4
A2167	Radio set, vehicular, AN/VRC88A	6
A2179	Terminal, radio, troposcatter, digital, AN/TRC170(V)5	16
A2505	Switchboard, telephone, automatic, SB3614(V)TT	2
A2508	Switching unit, telephone, automatic, SB3865	4
D1059	Truck, cargo, 5 ton, 6 x 6, M923A1	5

- w Coordinate and integrate MAGTF direct air support operations with those of other Services, allies, and nations.

c. Concept of Organization

The MASS is organic to the MACG. When supporting the MAGTF, the MASS is task organized as part of the ACE.

d. Concept of Employment

The MASS supports the MAGTF by control, coordination, and integration of direct air support operations in support of naval expeditionary, joint, and multinational operations. For additional information on the DASC, see MCWP 3-25.5, *Direct Air Support Center Handbook*.

e. Administrative Capabilities

The MASS is capable of self-administration.

f. Logistic Capabilities

(1) Maintenance. The MASS is capable of organizational (1st echelon) maintenance on all equipment; organizational (2d echelon) maintenance on motor transport equipment, ground-common HF radios, and infantry weapons; intermediate (3d echelon) maintenance on electrical systems of mobile electric power generators, air conditioning equipment, and ground-common communications-electronics equipment except for HF radios; and intermediate (3d and 4th echelon) maintenance on aviation-peculiar critical low-density secondary repairables and end items.

(2) Supply. The MASS is capable of performing supply and fiscal functions that are required for squadron operations and managing secondary repairable floats for critical low-density aviation-peculiar equipment.

(3) Transportation. The MASS possesses sufficient motor transport equipment to provide for the combat transportation requirements of the squadron. This includes the ability to displace in echelon.

(4) Medical. The MASS is capable of providing routine and emergency support by using organic Navy corpsmen.

(5) Messing. Food service support is provided by the supporting element.

(6) Selected Items of Equipment. For a list of items of equipment, see table 3-5 on page 3-18.

3307. Low-Altitude Air Defense Battalion

a. Mission

The LAAD battalion provides close-in, low-altitude, surface-to-air weapons fires in defense of MAGTF assets defending forward combat areas, maneuver forces, vital areas, installations, and/or units engaged in special/independent operations.

b. Tasks

- w Provide for the effective command, administrative, communications, supply, and logistic support of subordinate batteries.
- w Maintain a primary capability as a highly mobile, vehicle-mounted, and man-portable surface-to-air weapons component of the MAGTF with the ability to rapidly deploy in the assault echelon of an expeditionary operation.
- w Provide surface-to-air weapons support for units engaged in special/independent operations.
- w Provide for the separate deployment of subordinate batteries and platoons to accommodate special tactical situations and task organizations.
- w Plan and coordinate requirements for liaison and combinations with appropriate commands to ensure the most effective integration of LAAD units within the integrated air defense system.
- w Provide early warning of hostile air threats to other elements of the air defense system.

c. Concept of Organization

The LAAD battalion is comprised of a battalion headquarters, a headquarters and service (H&S) battery, and two firing batteries. The H&S battery has been divided into an H&S battery (-) and an H&S battery detachment. This organization facilitates the logistical support of separately deployed firing batteries. (See figure 3-8.)

Table 3-5. Selected Items of Equipment for the MASS.

TAM Number	Item	Quantity
A0010	Airborne mobile direct air support central, AN/UYQ3A(V)2	2
A0011	Fire Support Command and Control System, AN/UYK102	3
A0512	Direct air support central (improved), AN/TSQ155(V)	2
A0556	Downsized/improved mobility (IDASC PIP Phase I)	12
A1415	Radar set (LBSR), AN/PPS15A(V)2	3
D1059	Truck, cargo, 5 ton, 6 x 6, M932A1	19
D1061	Truck, cargo, 5 ton, long bed, M928	6
D1212	Truck, wrecker, 5 ton, 6 x 6, M936	1
E0312	Dual mount, machine gun, MK93 Mod 0	32
E0980	Machine gun, .50 cal, Browning, heavy barrel, flexible, M2	8
E0989	Machine gun, medium, 7.62 mm, M240G	3

d. Concept of Employment

The LAAD battalion is organized to provide LAAD capabilities that are consistent with the size of the MAGTF and the scope of the air defense plan. The battalion will normally be employed within the integrated air defense system of the MEF. For additional information on the LAAD battalion, see MCWP 3-25.10, *Low Altitude Air Defense Battalion Handbook*.

e. Administrative Capabilities

The H&S battery, as well as each firing battery, is capable of self-administration.

f. Logistic Capabilities

(1) Maintenance. The LAAD battalion is capable of organizational (1st echelon) maintenance of organic surface-to-air weapons system components and training devices; organizational (1st and 2d echelon) maintenance of all other organic equipment, including motor transport, engineering, communications, and individual weapons; and intermediate (3d and 4th echelon) maintenance on the Avenger weapon system, except for the missiles.

(2) Supply. The LAAD battalion is capable of organic supply.

(3) Transportation. The LAAD battalion possesses sufficient organic motor transport assets to support the unit mission.

(4) Medical. The LAAD battalion is capable of providing routine and emergency medical support by using organic Navy corpsmen.

(5) Messing. The LAAD battalion is capable of providing organic food service support.

(6) Selected Items of Equipment. For a list of equipment items, see table 3-6.

3401. General

The MAG is an administrative and tactical CE. It is the smallest aviation unit that is designed for independent operations with no outside assistance except access to a source of supply. Each MAG is task organized for the assigned mission. There are two types of MAGs within the MAW: rotary-wing (MAG VH) and fixed-wing (MAG VF/VA).

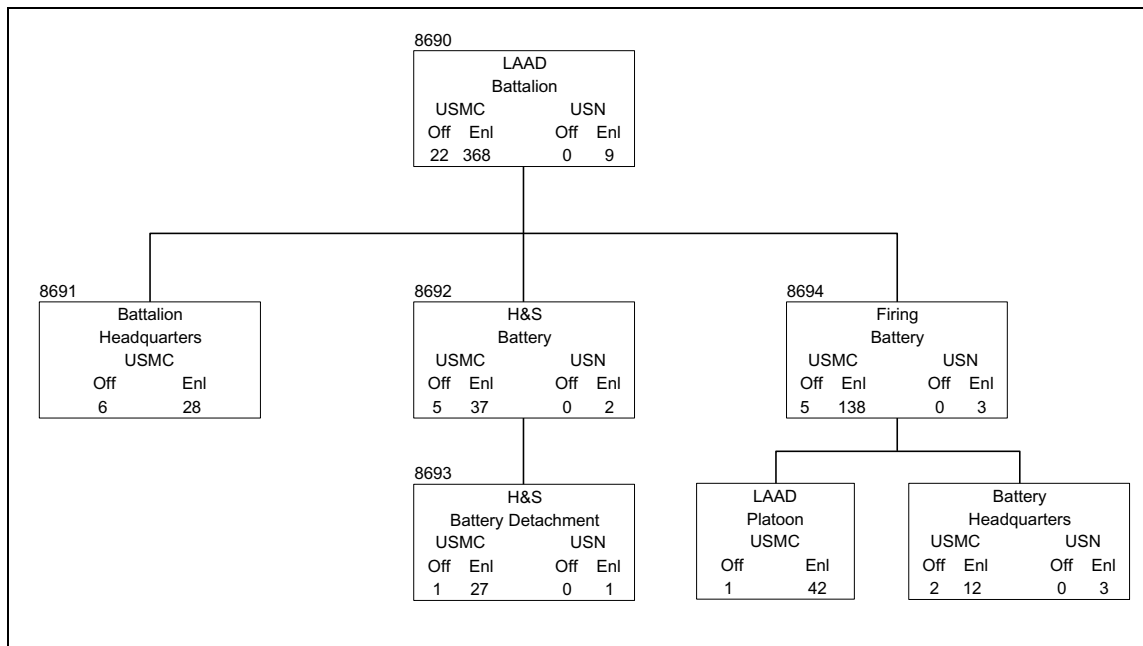

Figure 3-8. LAAD Battalion.

(See figures 3-9 and 3-10.) The primary mission of a MAG VF/VA is to conduct AAW and OAS operations from advance bases, FOBs, and aircraft carriers. MAG VF/VAs may consist of any combination of Marine attack squadron (VMAs), Marine fighter attack squadrons (VMFAs), Marine all-weather fighter attack squadrons (VMFA(AW)s), Marine aerial refueler transport squadrons (VMGRs), Marine unmanned aerial vehicle (UAV) squadrons (VMUs), Marine tactical EW squadrons (VMAQs), or MALS (fixed wing). The primary mission of the MAG VH is to provide assault support. Normally, the MAG VH includes one Marine light/attack helicopter squadron

HMLA), three Marine medium helicopter squadrons (HMMs), and two Marine heavy helicopter squadrons (HMHs), and one MALS (rotary wing). Each fixed- and rotary-wing MAG has a MALS.

3402. Marine Air Group Headquarters

a. Mission

Table 3-6. Selected Items of Equipment for the LAAD Battalion.

TAM Number	Item	Quantity
A0025	Communications platform, air defense (ADCP), AN/MSQ124	8
A0891	Radar set, alert, defense, tactical, AN/UPS3	15
D1059	Truck, cargo, 5 ton, 6 x 6, M923A1	4
D1212	Truck, wrecker, 5 ton, 6 x 6, M936	1
E0727	Interrogator set, IFF (Stinger), AN/PPX3B	180
E0990	Machine gun, .50 cal, M923	33
E0993	Machine gun, 7.62 mm, M60E3	8
E1836	Control central, battery, missile, guided (Avenger), AN/TWQ1	60

Section IV. Marine Aircraft Group (MAG)

The MAG headquarters provides the staff support necessary for the effective command of subordinate squadrons of the MAG.

b. Tasks

- w Perform those command and staff functions that are necessary to accomplish the MAG mission.
- w Plan and coordinate the deployment and employment of the MAG and its separately deployable squadrons.
- w Plan and coordinate individual and unit training to prepare subordinate squadrons for tactical deployment and combat operations.
- w Provide Marine Corps property supply support for subordinate squadrons.
- w Maintain cognizance over all fiscal functions accomplished within the MAG.

c. Concept of Organization

The MAG headquarters is organized into individual departments that are capable of performing the broad range of required staff functions.

d. Concept of Employment

The MAG headquarters will be employed with the ACE, where it may function in either a senior or subordinate staff role.

e. Administrative Capability

The MAG headquarters is capable of self-administration.

f. Logistic Capabilities

(1) Maintenance. The MAG headquarters is capable of organizational (1st echelon) maintenance on all organic Marine Corps equipment and organizational (2d echelon) maintenance of assigned infantry weapons and NBC equipment.

(2) Supply. The MAG headquarters is capable of providing the Marine Corps supply and fiscal functions that are required for MAG operations.

(3) Medical. The MAG headquarters is capable of providing routine and emergency medical support.

(4) Transportation. Motor transport is provided by the Marine wing support squadron (MWSS).

(5) Messing. Food service is provided by the MWSS.

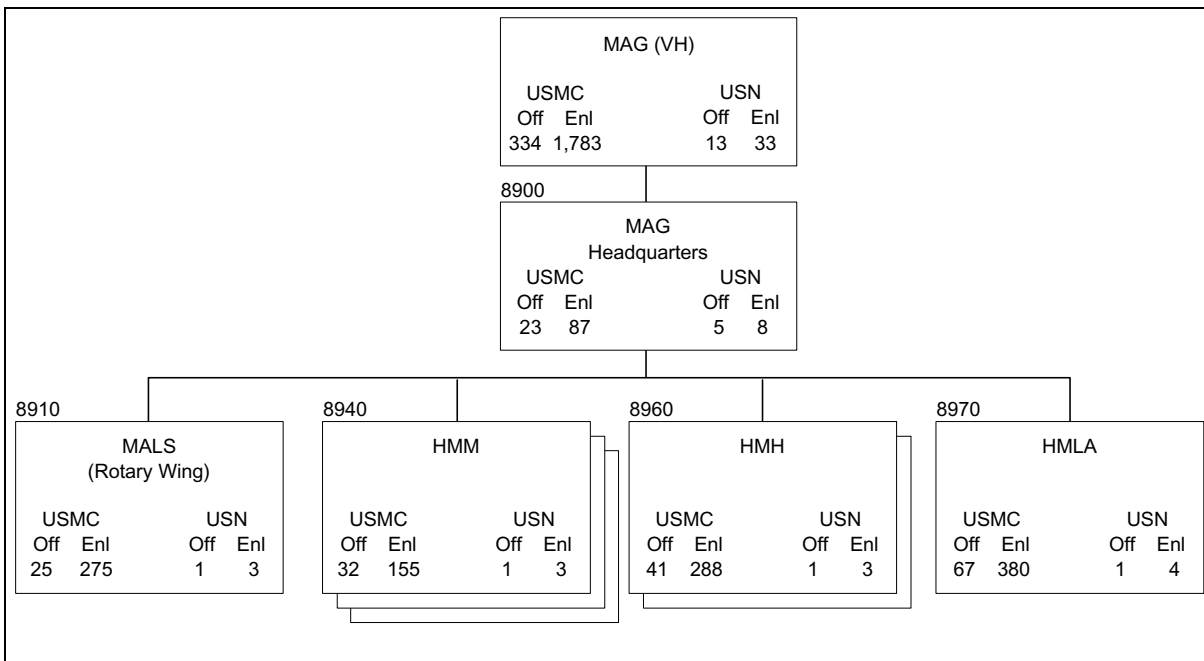

Figure 3-9. Notional MAG (Rotary Wing).

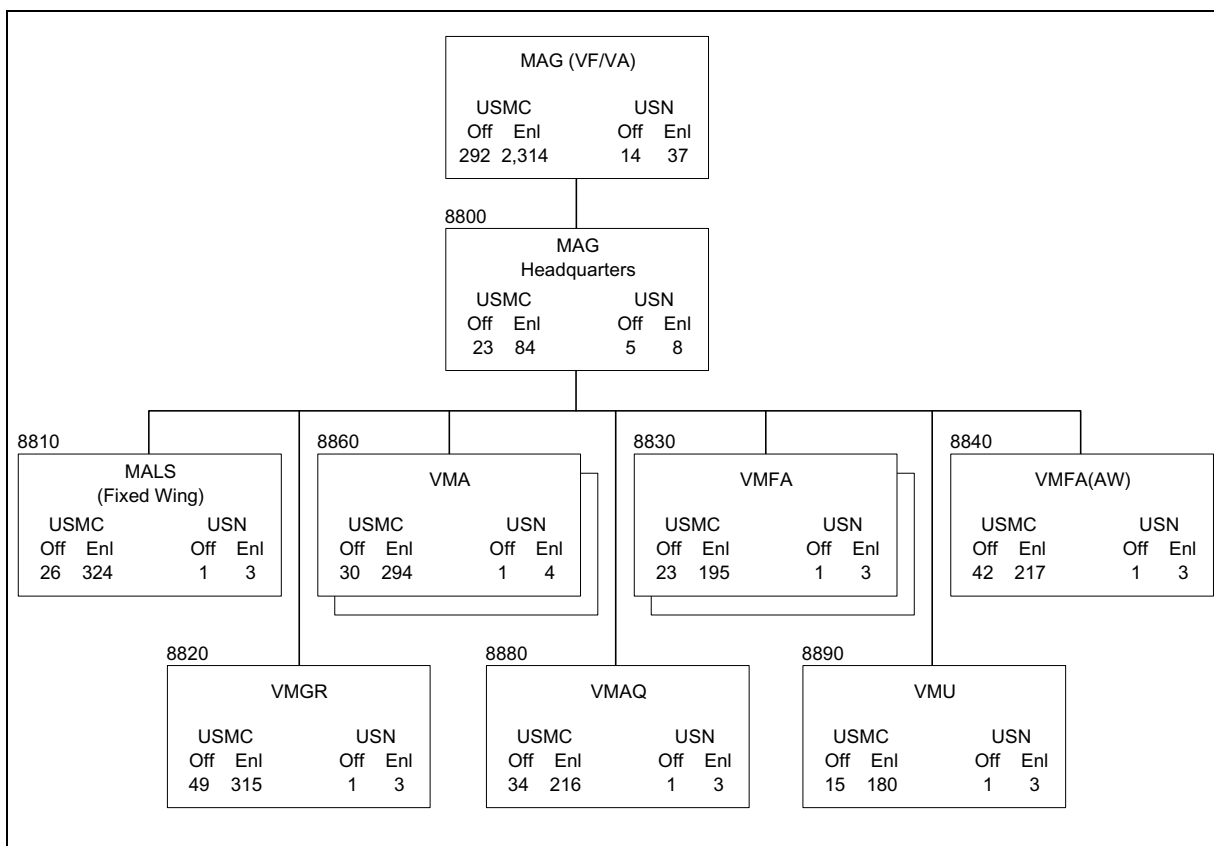

Figure 3-10. Notional MAG (Fixed Wing).

3403. Marine Aviation Logistics Squadron: Fixed Wing/Rotary Wing

a. Mission

The MALS provides aviation-logistic support, guidance, and direction to MAG squadrons on behalf of the commanding officer, as well as logistic support for Navy-funded equipment in the supporting MWSS, MACS, and Marine wing mobile calibration complex.

b. Tasks

- w Provide intermediate-level maintenance for aircraft and aeronautical equipment of all supported units and, when authorized, perform first-degree repair on specific engines.
- w Provide aviation supply support for aircraft and Navy-funded equipment to all supported units.
- w Provide class V(A) ammunition logistic support to the MAG's squadrons. This support encompasses the requisitioning, storage, handling, assembly, transportation, and inventory reporting of class V(A) ammunition. Be capable of planning for and operating an airfield ammunition issue point at expeditionary airfields.
- w Interpret, implement, audit, inspect, and provide oversight for the MAG commanding officer of all policies and procedures relating to the administration and management of operations and maintenance, Navy funds (except temporary additional duty funds), aviation supply, aircraft maintenance, aircraft ordnance, avionics, and cryogenics production for all units/squadrons within a MAG.
- w Coordinate with the MWSG, the MACG, the MAW calibration complex, and other supporting Navy and Marine Corps activities/agencies in planning for the support required to execute the Marine aviation logistic support program (MALSP).
- w Screen and inspect nonserviceable aeronautical materiel for testing and repair, shipment to another repair facility, or disposal.
- w Maintain the capability to deploy and provide MALSP support packages (including personnel) as an integral unit or as tailored logistic elements assigned to another MALS to support MAG aircraft assigned to a different MAG/ ACE.

- w Conduct individual and unit training to qualify organic and supported squadron personnel for performing assigned missions and tasks.
- w Provide data processing support to facilitate execution of the aviation supply, aircraft maintenance, and Navy-funded (except temporary additional duty funds) financial management functions of the MAG.

c. Concept of Organization

This squadron is organized as a core unit that is supplemented by aircraft-specific, MWSS, and MACS augmentees. This concept allows the squadron to provide logistical support to the MAG's aircraft squadrons, MWSSs, and MACSs in garrison or as a task-organized ACE.

d. Concept of Employment

The MALS is employed as an integral unit of a MAG within an ACE or can provide elements/support packages to another MALS that is supporting a MAGTF ACE.

e. Administrative Capability

The MALS is capable of self-administration.

f. Logistic Capability

(1) Maintenance. The MALS is capable of organizational (1st echelon) maintenance on all organic Marine Corps equipment and organizational (2d echelon) maintenance on assigned infantry weapons.

(2) Supply. The MALS is capable of performing aviation supply and fiscal functions that are required to support MAG operations and aircraft maintenance.

(3) Medical. The MALS is capable of providing routine and emergency medical support.

(4) Transportation. Transportation is provided by the MWSS.

(5) Messing. Food service support is provided by the MWSS.

3404. Marine Aerial Refueler Transport Squadron

a. Mission

The VMGR provides aerial refueling service in support of Fleet Marine Force (FMF) air operations and provides assault air transport of personnel, equipment, and supplies.

b. Tasks

- w Provide tactical aerial refueling service to FMF units.
- w Provide long-range aerial refueling service for air movement of FMF squadrons when other suitable means of aerial refueling services are not readily available.
- w Provide assault air transport for air-landed and air-delivered troops, supplies, and equipment when other suitable means of assault air transport are not readily available.
- w Provide an aircraft platform for the airborne DASC.
- w Provide ground refueling service to aircraft when other suitable means of aircraft refueling are not available.
- w Provide air transport service for the evacuation of casualties and noncombatants when other means of transportation are not available.
- w Within the capability of assigned aircraft and equipment, maintain the capability to operate under day, night, and all weather flying conditions; operate to/from a logistic air head, advance base, expeditionary airfield, or tactical landing zone in the objective area or battle area; and operate with or without the assistance of airborne, surface, or ground controllers.

c. Concept of Organization

The VMGR will function either as an integral unit or as separate detachments. Two detachments within the squadron organization provide the capability to conduct dual-site operations and support simultaneous contingencies. The VMGR has 12 KC-130 aircraft.

d. Concept of Employment

This squadron will normally be employed in general support of FMFs as directed by the MAGTF commander. The unit may be employed either as an entire squadron or as two six-plane detachments.

e. Administrative Capabilities

This squadron is capable of self-administration.

f. Logistic Capabilities

(1) Maintenance. This squadron is capable of 1st and 2d echelon maintenance on all assigned equipment and infantry weapons and of providing organizational maintenance on assigned aircraft.

(2) Supply. Supply support is provided by the MALS and the MAG headquarters.

(3) Transportation. Transportation support is provided by the MWSS.

(4) Medical. The VMGR is capable of providing routine and emergency medical support.

(5) Messing. Food service support is provided by the MWSS.

3405. Marine Tactical Electronic Warfare Squadron

a. Mission

The VMAQ conducts airborne EW in support of FMF operations.

b. Tasks

- w Conduct airborne EA and EW support operations.
- w Conduct EA in support of training of FMF units or other forces as assigned.
- w Process and provide mission data from tape recordings obtained on EW missions for updating and maintaining an electronic order of battle.
- w Maintain the capability of operating from aircraft carriers, advance bases, and expeditionary airfields.
- w Maintain the capability to operate during darkness and under all weather conditions.

- w Maintain the capability to deploy or conduct extended-range operations that require aerial refueling.
- w Perform organizational maintenance on assigned aircraft.

c. Concept of Organization

The VMAQ is organized to function independently with its own logistic and administrative support capabilities. The squadron is structured to operate as a subordinate unit of a MAG or carrier air wing. Each squadron has five EA-6B aircraft.

d. Concept of Employment

The VMAQ will normally be employed in general support of the FMF or other assigned forces.

e. Administrative Capability

This squadron is capable of self-administration.

f. Logistic Capabilities

(1) Maintenance. This squadron is capable of organizational (1st echelon) maintenance on all assigned Marine Corps-funded equipment and organizational (2d echelon) maintenance on infantry weapons. It is authorized to perform 1st through 4th echelon maintenance on Tactical Electronic Reconnaissance Processing and Evaluation System (TERPES) commercial-off-the-shelf or nondevelopmental items (COTS/NDI), with 5th echelon maintenance being performed by equipment manufacturers/vendors. It is capable of performing organizational maintenance on assigned aircraft and Navy-funded equipment. Intermediate-level ordnance, avionics, aircraft maintenance, and other aviation logistic support is provided by the supporting MALS.

(2) Supply. Supply support is provided by the MALS and the MAG headquarters.

(3) Transportation. Motor transport support is provided by the MWSS.

(4) Medical. The VMAQ is capable of providing routine and emergency medical support.

(5) Messing. Food service support is provided by the MWSS.

3406. Marine Unmanned Aerial Vehicle Squadron

a. Mission

The VMU operates and maintains a UAV system to provide unmanned aerial reconnaissance support to the MAGTF.

b. Tasks

- w Conduct reconnaissance, surveillance, and target acquisition (RSTA). This includes performing airborne surveillance of designated target areas, MAGTF areas of interest/influence, and other areas as directed; airborne surveillance for search and rescue (SAR) and TRAP; and reconnaissance of helicopter approach and retirement lanes in support of vertical assaults.
- w Provide real-time target information to the DASC and fire support coordination center (FSCC) to facilitate adjusting fire missions and CAS.
- w Provide information to assist adjusting indirect- fire weapons and to support and facilitate DAS and air interdiction.
- w Collect battle damage assessments (BDAs).
- w Support rear area security.
- w Provide remote receive capability and liaison to designated units.
- w Conduct individual and unit training to prepare for tactical employment and combat operations.

c. Concept of Organization

The VMU is organic to the MAW and is structured to operate as a subordinate unit of one of the MAGs. The VMU is organized into various sections that give it the capability to operate and maintain one UAV system and associated support equipment. Its MALS augment section is designed to provide intermediate-level aviation maintenance and supply support. The VMU has one Pioneer system with five UAVs.

d. Concept of Employment

The VMU can support any size MAGTF. Normal employment would be as an integral unit of an ACE in support of MAGTF operations. The squadron is capable of limited independent operations.

e. Administrative Capability

The squadron is capable of self-administration.

f. Logistic Capabilities

(1) Maintenance. The squadron is capable of conducting 1st and 2d echelon maintenance on assigned Marine Corps ground equipment, including motor transport, engineering and communications equipment, and infantry weapons. The CSS detachment (CSSD) performs 3d and 4th echelon maintenance on ground equipment. The squadron is also capable of performing organizational maintenance on aviation equipment. The MALS performs limited, specialized intermediate-level maintenance on aviation equipment.

(2) Supply. Supply support is provided by the MAG and the MALS.

(3) Transportation. The squadron is capable of providing sufficient motor transportation to displace the operational capability of one UAV system. Additional transportation support is required to displace all equipment of the VMU simultaneously.

(4) Medical. The squadron is capable of providing routine and emergency medical support.

(5) Messing. Food service support is provided by the MWSS.

3407. Marine Fighter Attack Squadron

a. Mission

The VMFA intercepts and destroys enemy aircraft under all weather conditions and attacks and destroys surface targets.

b. Tasks

- w Intercept and destroy enemy aircraft in conjunction with ground or airborne fighter control under all weather conditions.
- w Maintain the capability to attack and destroy surface targets by using all types of conventional weapons that are compatible with assigned aircraft.
- w Provide escort of friendly aircraft under all weather conditions.
- w Maintain the capability to deploy and operate from aircraft carriers and advance bases.
- w Conduct day and night CAS under adverse weather conditions.
- w Maintain the capability to deploy or conduct extended-range operations by using aerial refueling.
- w Maintain the capability to conduct suppression of enemy air defense (SEAD) operations.
- w Perform organizational maintenance on assigned aircraft.

c. Concept of Organization

This squadron will normally function as an integral unit. It is structured to operate as a subordinate unit of a MAG. Each squadron has 12 F/A-18A/C aircraft.

d. Concept of Employment

The VMFA will normally be employed as an integral unit of an ACE.

e. Administrative Capabilities

This squadron is capable of self-administration.

f. Logistic Capabilities

(1) Maintenance. The VMFA is capable of organizational (1st echelon) maintenance on all assigned equipment and organizational (2d echelon) maintenance on infantry weapons. It is capable of performing organizational maintenance on assigned aircraft and support equipment.

(2) Supply. Supply support is provided by the MALS and the MAG headquarters.

(3) Transportation. Motor transport support is provided by the MWSS.

(4) Medical. This squadron is capable of providing routine and emergency medical support.

(5) Messing. Food service support is provided by the MWSS.

3408. Marine All-Weather Fighter Attack Squadron

a. Mission

The VMFA(AW) attacks and destroys surface targets, day or night, under adverse weather conditions; conducts multisensor imagery reconnaissance; provides supporting arms coordination; and intercepts and destroys enemy aircraft under all weather conditions.

b. Tasks

- w Conduct day and night CAS, under all weather conditions.
- w Conduct day and night DAS, under adverse weather conditions, including armed reconnaissance, radar search and attack, air interdiction, and strikes against enemy installations, by using all types of weapons that are compatible with assigned aircraft.
- w Conduct multisensor imagery reconnaissance, including prestrike and poststrike target damage assessment and visual reconnaissance.
- w Conduct day and night supporting arms coordination, including forward air control, tactical air coordination, and artillery/naval gunfire spotting.
- w Intercept and destroy enemy aircraft in conjunction with ground and airborne fighter direction.
- w Conduct battlespace illumination and target illumination.
- w Conduct armed escort of friendly aircraft.
- w Maintain the capability to operate from aircraft carriers, advance bases, and expeditionary airfields.

- w Maintain the capability to deploy or conduct extended-range operations by using aerial refueling.
- w Maintain the capability to conduct SEAD operations.
- w Perform organizational maintenance on assigned aircraft.

c. Concept of Organization

The VMFA(AW) will normally function as an integral unit. It is structured to operate as a subordinate unit of a MAG. Each squadron has 12 F/A-18D aircraft.

d. Concept of Employment

This squadron will normally be employed as an internal unit of an ACE.

e. Administrative Capability

This squadron is capable of self-administration.

f. Logistic Capabilities

(1) Maintenance. This squadron is capable of organizational (1st echelon) maintenance on all assigned Marine Corps equipment and organizational (2d echelon) maintenance on infantry weapons. It is also capable of performing organizational maintenance on assigned aircraft and support equipment.

(2) Supply. Supply support is provided by the MALS and MAG headquarters.

(3) Transportation. Motor transport is provided by the MWSS.

(4) Medical. This squadron is capable of providing routine and emergency medical support.

(5) Messing. Food service is provided by the MWSS.

3409. Marine Attack Squadron

a. Mission

The VMA attacks and destroys surface targets under day and night visual meteorological conditions and provides helicopter escort.

b. Tasks

- w Conduct CAS.
- w Conduct armed reconnaissance, air interdiction, and strikes against enemy installations by using all types of conventional munitions that are compatible with assigned aircraft.
- w Conduct air defense operations within the capability of assigned aircraft.
- w Maintain the capability to operate during darkness and under instrument conditions.
- w Maintain the capability of deployment or extended operations by employing aerial re-fueling.
- w Maintain the capability to operate from aboard carriers, other suitable seagoing platforms, expeditionary airfields, and remote tactical landing sites.
- w Conduct armed-escort missions in support of helicopter operations.
- w Perform organizational maintenance on assigned aircraft.

c. Concept of Organization

This squadron will function either as an integral unit or as a squadron (-) with a deployed aircraft detachment. This concept of organization facilitates dual-site operations, provides for the support of simultaneous contingencies, and allows for the fulfillment of continuous unit deployment program requirements. Each squadron has 16 AV-8B aircraft, 10 in the squadron and 6 in the detachment.

d. Concept of Employment

This squadron will normally be employed as an integral unit of an ACE. The squadron may be employed as a complete squadron or as a squadron (-) with a deployed six-aircraft detachment.

e. Administrative Capability

This squadron is capable of self-administration.

f. Logistic Capability

(1) Maintenance. This squadron is capable of organizational (1st echelon) maintenance on all assigned Marine Corps equipment and organizational (2d echelon) maintenance on infantry weapons. It is also capable of performing organizational maintenance on assigned aircraft and support equipment.

(2) Supply. Supply support is provided by the MALS and the MAG headquarters.

(3) Transportation. Motor transport support is provided by the MWSS.

(4) Medical. This squadron is capable of providing routine and emergency medical support.

(5) Messing. Food service support is provided by the MWSS.

3410. Marine Heavy Helicopter Squadron (CH-53D)

a. Mission

The HMH provides assault helicopter transport of heavy weapons, equipment, and supplies during amphibious operations and subsequent operations ashore.

b. Tasks

- w Provide combat assault transport of heavy weapons, equipment, and supplies as a primary function.
- w Provide combat assault transport of troops (exclusive of initial assault wave infantry) as a secondary function.
- w Conduct tactical retrieval and recovery operations for downed aircraft, equipment, and personnel.
- w Conduct assault support for evacuation operations and other maritime special operations.
- w Provide support for mobile forward arming and refueling points (FARPs).

- w Augment local SAR and provide aeromedical evacuation of casualties from the field to suitable medical facilities or other aeromedical aircraft.
- w Provide airborne control and coordination for assault support operations.
- w Maintain a self-defense capability from ground-to-air and air-to-air threats.
- w Maintain the capability to operate from amphibious shipping, other floating bases, and austere shore bases, as required.
- w Maintain the capability to operate at night, in adverse weather conditions, and under instrument flight conditions at extended ranges.
- w Perform organizational maintenance on assigned aircraft in all environmental conditions.

c. Concept of Organization

This squadron will function either as an integral unit or as a squadron (-) with one or two separate detachments. This concept of organization facilitates dual-site operations, provides support for simultaneous contingencies, and allows for the fulfillment of continuous unit deployment program requirements. Each squadron has eight CH-53D aircraft organized in two detachments of four aircraft each. All squadrons fall under the aviation support element based in Kanehoe Bay, HI. Squadrons are sourced out as operational needs arise.

d. Concept of Employment

This squadron, or its separate detachments, will normally be employed as an integral unit of an ACE. The squadron may be employed as a single unit or with one or two separate four-plane detachments.

e. Administrative Capabilities

This squadron is capable of self-administration.

f. Logistic Capabilities

(1) Maintenance. This squadron is capable of organizational (1st echelon) maintenance on all assigned equipment and organizational (2d echelon) maintenance on infantry

weapons. It is capable of performing organizational maintenance on assigned aircraft and support equipment.

(2) Supply. Supply support is provided by the MALS and the MAG headquarters.

(3) Transportation. Motor transport support is provided by the MWSS.

(4) Medical. This squadron is capable of providing routine and emergency medical support.

(5) Messing. Food service support is provided by the MWSS.

3411. Marine Heavy Helicopter Squadron (CH-53E)

a. Mission

This squadron provides assault helicopter transport of heavy weapons, equipment, and supplies during amphibious operations and subsequent operations ashore.

b. Tasks

- w Provide combat assault transport of heavy weapons, equipment, and supplies as a primary function.
- w Provide combat assault transport of troops (exclusive of initial assault wave infantry) as a secondary function.
- w Conduct tactical retrieval and recovery operation for downed aircraft, equipment, and personnel.
- w Conduct assault support for evacuation operations and other maritime special operations.
- w Provide support for FARPs.
- w Augment local SAR assets and provide aeromedical evacuation of casualties from the field to suitable medical facilities or other aeromedical aircraft.
- w Provide airborne control and coordination for assault support operations.
- w Maintain the capability to deploy and conduct extended-range operations by employing aerial refueling.

- w Maintain a self-defense capability from ground-to-air and air-to-air threats.
- w Maintain the capability to operate from amphibious shipping, other floating bases, and austere shore bases, as required.
- w Maintain the capability to operate at night, in adverse weather conditions, and under instrument flight conditions at extended ranges.
- w Perform organizational maintenance on assigned aircraft in all environmental conditions.

c. Concept of Organization

This squadron will normally function either as an integral unit or as a squadron (-) with one or two separate detachments. This concept of organization facilitates dual-site operations, provides for the support of simultaneous contingencies, and allows for the fulfillment of continuous unit deployment program requirements. Each squadron has 16 CH-53E aircraft.

d. Concept of Employment

This squadron or its separate detachments will normally be employed as an integral unit of an ACE. The squadron may deploy as a complete squadron or as one or two four-plane detachments.

e. Administrative Capabilities

This squadron is capable of self-administration.

f. Logistic Capabilities

(1) Maintenance. This squadron is capable of organizational (1st echelon) maintenance on all assigned equipment and organizational (2d echelon) maintenance on infantry weapons. It is capable of performing organizational maintenance on assigned aircraft and support equipment.

(2) Supply. Supply support is provided by the MALS and the MAG headquarters.

(3) Transportation. Motor transport support is provided by the MWSS.

(4) Medical. This squadron is capable of providing routine and emergency medical support.

(5) Messing. Food service support is provided by the MWSS.

3412. Marine Medium Helicopter Squadron

a. Mission

The HMM provides assault transport of combat troops in the initial assault waves and follow-on stages of amphibious operations and subsequent operations ashore.

b. Tasks

- w Provide combat assault troop transport as a primary function.
- w Provide combat assault transport of supplies and equipment as a secondary function.
- w Conduct assault support for evacuation operations and other maritime special operations.
- w Provide support for mobile FARPs.
- w Provide airborne control and coordination for assault support operations.
- w Maintain a self-defense capability from ground-to-air and air-to-air threats.
- w Maintain the capability to operate from amphibious shipping, other floating bases, and austere shore bases.
- w Maintain the capability to operate at night, in adverse weather conditions, and under instrument flight conditions at extended ranges.
- w Augment local SAR assets and provide aeromedical evacuation of casualties from the field to suitable medical facilities or other aeromedical aircraft.
- w Perform organizational maintenance on assigned aircraft in all environmental conditions.

c. Concept of Organization

This squadron will normally function as an integral unit. It is structured to operate as a subordinate unit of a MAG. Each squadron has 12 CH-46E aircraft.

Tactical HMMs will begin replacing the CH-46E helicopter with the MV-22 tilt-rotor aircraft beginning in fiscal year 2002. The MV-22 is a dual-piloted, multiengine, self-deployable, medium-lift, vertical takeoff and landing

(VTOL) tilt-rotor aircraft that provides combat assault support, CSS, and special operations support worldwide. The aircraft will operate from air-capable ships, main bases ashore, and austere forward operating locations. The MV-22 is capable of in-flight refueling, has a 2,100 nautical mile deployment range, and can carry 24 combat-equipped troops or a 10,000-pound external load. The squadron may have a mission and tasks similar to those of the current unit operating with CH-46E aircraft.

d. Concept of Employment

This squadron will normally be employed as an integral unit of an ACE.

e. Administrative Capability

This squadron is capable of self-administration.

f. Logistic Capabilities

(1) Maintenance. This squadron is capable of organizational (1st echelon) maintenance on all assigned equipment and organizational (2d echelon) maintenance on infantry weapons. It is capable of performing organizational maintenance on assigned aircraft and support equipment.

(2) Supply. Supply support is provided by the MALS and the MAG headquarters.

(3) Transportation. Motor transport support is provided by the MWSS.

(4) Medical. The HMM is capable of providing routine and emergency medical support.

(5) Messing. Food service support is provided by the MWSS.

3413. Marine Light/Attack Helicopter Squadron

a. Mission

The HMLA provides combat utility helicopter support, attack helicopter fire support, and fire support coordination during amphibious operations and subsequent operations ashore.

b. Tasks

(1) Utility Helicopter Tasks

- w Provide an airborne command and control platform for CEs.
- w Provide armed escort for assault support operations.
- w Provide combat assault transport of troops, supplies, and equipment.
- w Provide airborne control and coordination for assault support operations.
- w Augment local SAR assets and provide aeromedical evacuation of casualties from the field to suitable medical facilities or other aeromedical aircraft.
- w Conduct combat assault and assault support for evacuation operations and other maritime special operations.
- w Control, coordinate, and provide terminal guidance for supporting arms, including CAS, artillery, mortars, and naval gunfire (NGF).
- w Provide fire support and security for forward and rear area forces.
- w Maintain a self-defense capability from surface-to-air and air-to-air threats.
- w Maintain the capability to operate from amphibious shipping, other floating bases, and austere shore bases, as required.
- w Maintain the capability to operate at night, in adverse weather conditions, and under instrument flight conditions at extended ranges.
- w Perform organizational maintenance on assigned aircraft in all environmental conditions.

(2) Attack Helicopter Tasks

- w Provide fire support and security for forward and rear area forces.
- w Conduct point target/antiarmor operations.
- w Conduct antihelicopter operations.
- w Provide armed escort, control, and coordination for assault support operations.

- w Control, coordinate, and provide terminal ordnance for supporting arms, including CAS, artillery, mortars, and NGF.
- w Provide point and limited-area air defense from threat fixed-wing aircraft.
- w Conduct armed and visual reconnaissance.
- w Augment local SAR assets.
- w Maintain the capability to operate from amphibious shipping, other floating bases, and austere shore bases as required.
- w Maintain the capability to operate at night, in adverse weather conditions, and under instrument flight conditions at extended ranges.
- w Perform organizational maintenance on assigned aircraft in all environmental conditions.

c. Concept of Organization

This squadron will function either as an integral unit or as a squadron (-) with separate aircraft composite detachments. This concept of organization facilitates dual-site operations, provides for the support of simultaneous contingencies, and allows for the fulfillment of continuous unit deployment program requirements. Each squadron has 18 AH-1W and 9 UH-1N aircraft.

d. Concept of Employment

The HMLA will normally be employed as an integral unit of an ACE. The squadron may deploy as a complete unit, or in three detachments consisting of six AH-1 and three UH-1 aircraft per detachment.

e. Administrative Capability

This squadron is capable of self-administration.

f. Logistic Capability

(1) Maintenance. This squadron is capable of organizational (1st echelon) maintenance on all assigned Marine Corps equipment and organizational (2d echelon) maintenance on infantry weapons. It is capable of performing organizational maintenance on assigned aircraft and support equipment. Detachments of this squadron are not capable of self-support and will be assigned to applicable units that possess the general organizational capability for their remaining logistic requirements.

(2) Supply. Supply support is provided by the MALS and the MAG headquarters.

(3) Transportation. Motor transport support is provided by the MWSS.

(4) Medical. This squadron is capable of providing routine and emergency medical support.

(5) Messing. Food service support is provided by the MWSS.

Section V. Marine Wing Support Group

3501. General

The MWSG (figure 3-11) provides all essential ground support requirements to aid designated fixed- or rotary-wing components of a Marine FOB. The MWSG typically includes a headquarters and headquarters squadron (H&HS), two MWSSs (fixed wing), and two MWSSs (rotary wing). The group is organized to provide motor transport, engineering services, and organizational maintenance (motor transport and engineering) for units of the MAW. The MWSG is organized and equipped for employment as an integral unit in support of the MAW. It is structured to provide deployable elements in support of the garrison or deployed posture of the MAW.

3502. Headquarters and Headquarters Squadron

a. Mission

The H&HS provides administrative support for the group and squadron headquarters.

b. Tasks

- w Provide command, control, administrative, and ecclesiastical support for assigned units.
- w Provide routine and emergency sick call functions.

c. Concept of Organization

This organization will normally function as an integral unit. It is structured to operate as the command and control element of the MWSG.

d. Concept of Employment

This organization functions as an integral unit of the MWSG in support of the MAW and its assigned unit(s).

e. Administrative Capabilities

This organization is capable of self-administration.

f. Logistic Capabilities

(1) Maintenance. This organization is capable of organizational (1st echelon) maintenance on all assigned

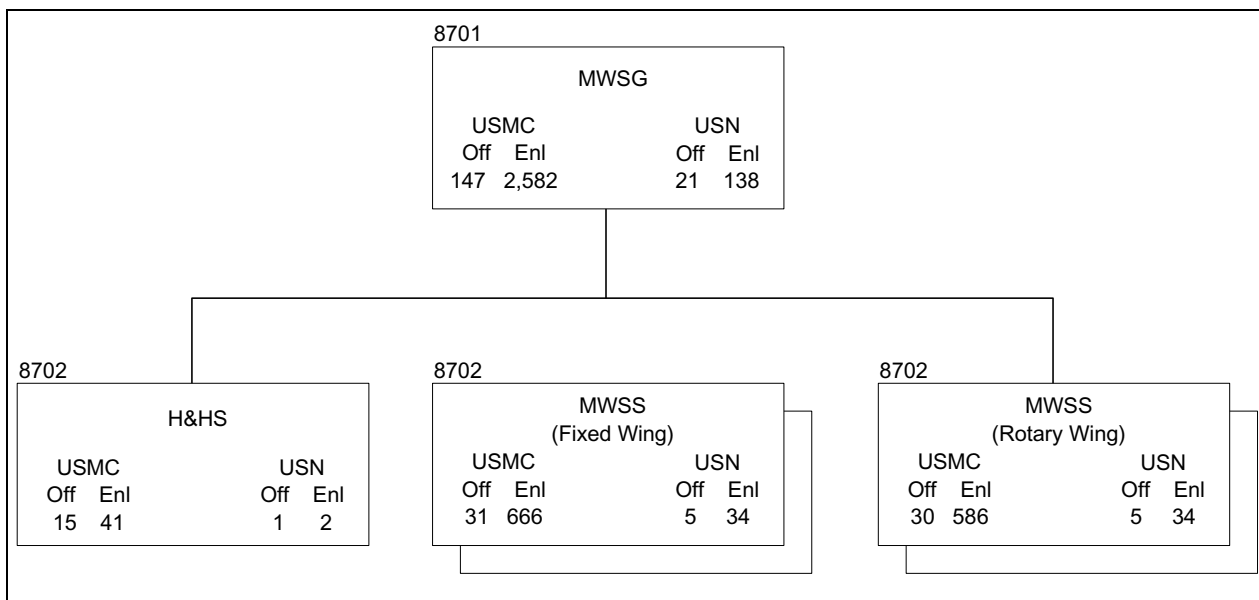

Figure 3-11. Marine Wing Support Group.

equipment and organizational (2nd echelon) maintenance on assigned NBC defense equipment.

(2) Supply. The H&HS possesses the capability to perform organic supply functions. It supervises organic supply functions of subordinate MWSG units.

(3) Transportation. Transportation is provided by collocated MWSG unit(s).

(4) Medical. The H&HS is capable of providing routine and emergency sick call.

(5) Messing. Messing support is provided by collocated MWSG unit(s).

3503. Marine Wing Support Squadron: Fixed Wing/Rotary Wing

a. Mission

The MWSS provides all essential aviation ground support requirements to a designated fixed-wing/ rotary-wing component of an ACE and all supporting or attached elements of the MACG.

b. Tasks

The MWSS conducts airfield operations, except for ATC, for supported ACE unit(s). These operations include:

- w Providing internal airfield communications, including tactical telephone service in and about the airfield as well as for tenant ACE units, communications for airfield security, communications for ground transportation management, and communications between an airfield and its adjacent facilities (i.e., ammunition dump and petroleum, oils, and lubricants sites).
- w Providing weather services.
- w Providing expeditionary airfield services, including maintaining M-21 aircraft recovery equipment, fresnel lens, communications, airfield lighting, and other related equipment necessary to support air operations.
- w Supplying crash/fire/rescue and structural firefighting equipment.
- w Providing aircraft and ground refueling.
- w Providing essential engineer services, including engineer reconnaissance/survey; repair, improvement, and maintenance of existing road nets within the ACE area of responsibility; construction and maintenance of expedient roads; construction (except for subsurface and surface preparation) improvement and maintenance of V/STOL facilities, not to exceed 900 feet; construction and maintenance of mission-essential base camp requirements, including tactical airfield fuel distribution systems and helicopter expeditionary refueling system installations, temporary bunkers, temporary aircraft revetments, and strongbacks; technical and equipment assistance for erection of shelters; utilities support, including essential mobile electric power, water, and hygiene support; development, improvement, and maintenance of drainage systems; supervision of camouflage requirements; equipment and personnel required for rapid runway repair; materials handling equipment to support base operations; limited mine detection capability; and limited combat engineer services.
- w Providing motor transport for operations internal to the air base.
- w Providing messing facilities.
- w Providing routine and emergency sick call and aviation medical functions.
- w Providing individual and unit training or organic personnel and selected personnel of support units.
- w Providing organic NBC defense.
- w Providing security and law enforcement services, including security of flight line and critical airfield facilities; traffic control/enforcement, convoy escort, and traffic accident investigation; straggler collection and refugee control; and criminal investigation, physical security surveys, and related activities.
- w Providing air base commandant functions.

c. Concept of Organization

The MWSS will normally function as an integral unit. It is structured to operate as a subordinate unit of the MWSG.

d. Concept of Employment

This organization functions as an integral unit of the ACE.

e. Administrative Capabilities

This organization is capable of self-administration.

f. Logistic Capabilities

(1) Maintenance. This organization is capable of organizational (1st and 2nd echelon) maintenance of all assigned engineer, motor transport, communications, field food service, and NBC defense equipment, as well as weapons. It is capable of intermediate (3d and limited 4th echelon) maintenance on expeditionary airfield systems equipment and provides organizational (2d echelon) maintenance of engineer and motor transport equipment of supported unit(s), except for the elements of the MACG.

(2) Supply. This organization is capable of performing supply and fiscal functions that are required for squadron operations with the exception of Navy-funded equipment, which requires support from a designated aviation element.

(3) Transportation. This organization possesses sufficient motor transport equipment to accomplish assigned missions and tasks.

(4) Medical. This organization is capable of providing routine and emergency medical support.

(5) Messing. This organization provides food services support for the air base/facility.

(6) Selected Items of Equipment. For a list of equipment items, see table 3-7.

Table 3-7. Selected Items of Equipment for the MWSS.

TAM Number	Item	Quantity
A0421	Communications system, crash/fire/rescue (base station mode), AN/GRC237	3
A0422	Communications system, crash/fire/rescue (vehicle mode), OG196/PRC	12
A0815	Lighting set, helicopter, portable	4
A1011	Marine CSS Command and Control System	14
A1415	Radar set (LBSR), AN/PPS15A(V)2	8
B0055	Bath shower unit, expeditionary, field	5
B0443	Crane, high speed, high mobility, with pile-driver capacity	2
B0471	Demolition equipment, engineer squad	2
B0475	Detecting set, mine, metallic, portable, AN/PSS12	2
B0590	Excavator, hydraulic, multipurpose, wheeled, MC40DR	2 fixed wing/1 rotary wing
B0591	Excavator, hydraulic, medium weight, rough terrain, MC1085C	1
B0675	Fuel dispensing system, airfield, tactical (Firestone), MM1966	6 fixed wing/ 4 rotary wing
B1082	Grader, road, motorized, 130G	2
B1135	Refueling system, expedient, helicopter	2 fixed wing/7 rotary wing
B1226	Laundry unit, field, MTR-3510-013	4 fixed wing/3 rotary wing
B1300	Platform, maintenance, crane, air mobile	3
B1775	Ripper attachment, three shank, MTG F/TRCTR, full-tracked D7G	2
B1785	Roller, compactor, vibratory, 420-C RAYGO	2 fixed wing/1 rotary wing
B2460	Tractor, full tracked, with angle blade, T5	2
B2462	Tractor, full tracked, medium, D7G	4
B2464	Tractor, full tracked, with multipurpose bucket, MC1150E	2
B2482	Tractor, all wheel drive, with attachments, FLU 419	2
B2561	Truck, forklift, extendable boom, DT-970424	13 fixed wing/14 rotary wing
B2566	Truck, forklift, rough terrain, 4,000 lb, 8606	6
B2567	Tractor, rough terrain, articulated steer, 644E	9 fixed wing/8 rotary wing
B2604	Purification unit, water, reverse osmosis	12 fixed wing/9 rotary wing
B2628	Purification unit, water, fresh, medium, 3,000-gal limit	2 fixed wing/3 rotary wing
D0215	Semitrailer, refueler, 5,000 gal, four wheel, M970	10
D0235	Semitrailer, low bed, 40 ton, M870A1	4
D0876	Trailer, powered, 22 1/2 ton, container hauler, 4 x 4, make 14 model 0	1 fixed wing/2 rotary wing
D0878	Trailer, powered, fifth wheel, semitrailer adapter, 4 x 4, make 16 model 0	4
D1061	Truck, cargo, 5 ton, long bed, M928	4
D1064	Truck, fire fighting, aircraft and structure, A/S32P19A	25 fixed wing/21 rotary wing
D1072	Truck, dump, 5 ton, 6 x 6, M929	6
D1082	Truck, fire fighting, 1 1/4 ton, 4 x 4, M1028FF	2
D1212	Truck, wrecker, 5 ton, 6 x 6, M936	2
E0312	Dual mount, machine gun, MK93 model 0	84
E0980	Machine gun, .50 cal, Browning, heavy barrel, flexible, M2	6
E0989	Machine gun, medium, 7.62 mm, ground version, M240G	18
E0993	Machine gun, 7.62 mm, M60E3	18
E0994	Machine gun, 40 mm, MK19 model 3	6

Chapter 4

Marine Divisions

4001. Marine Division

a. Mission

The mission of the Marine division is to execute amphibious assault operations and such other operations as may be directed. The Marine division must be able to provide the ground amphibious forcible-entry capability to an amphibious task force (ATF) and conduct subsequent land operations in any operational environment. The division commander fights by using combined-arms tactics and tailors the force to the demands of each mission.

b. Concept of Employment

The Marine division is employed as the GCE of the MEF or may provide task-organized forces for smaller MAGTFs. See figure 4-1 for Marine division organization.

c. CSS

The Marine division depends on the FSSG as its primary source of CSS. However, the organic capability of the division must be fully understood and used before requesting support from the FSSG. In the areas of combat engineer

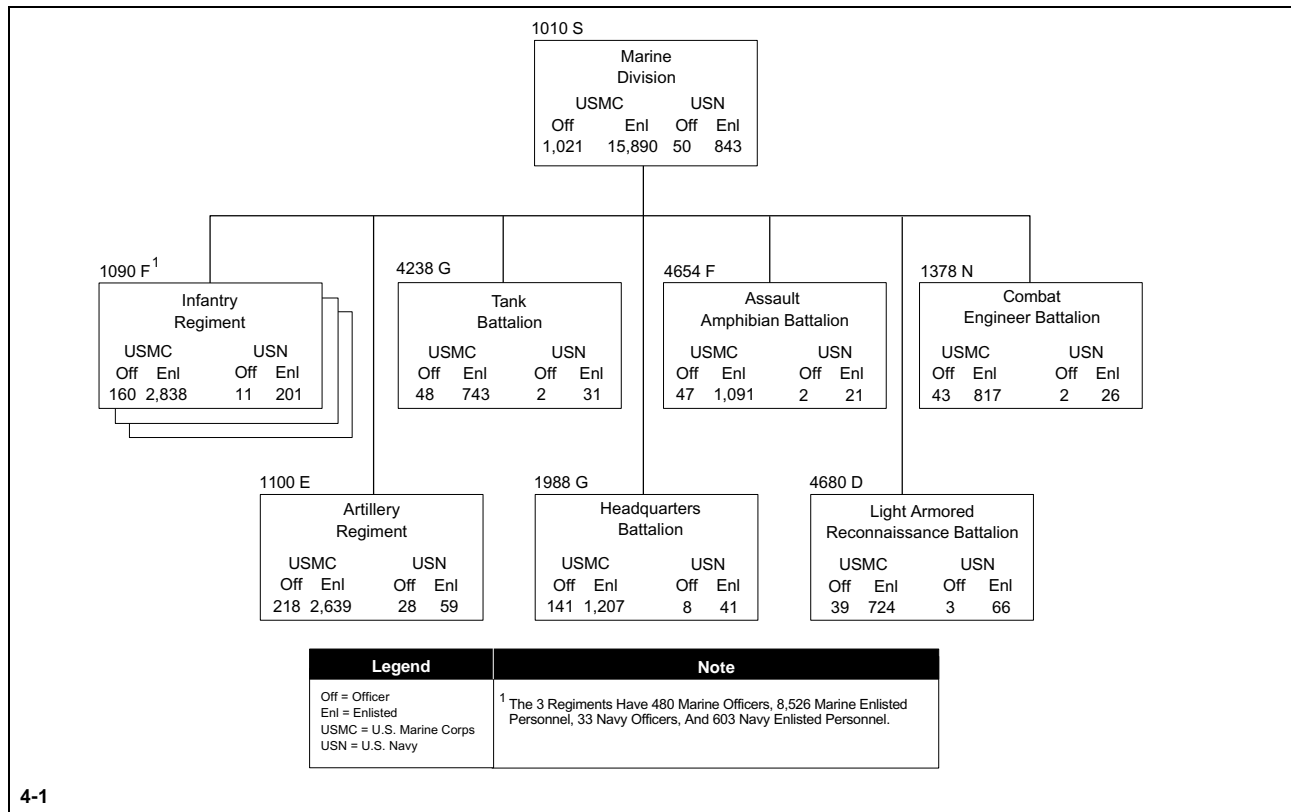

4-1

Figure 4-1. Marine Division Organization.

support and motor transport support, the division possesses the significant capabilities of the combat engineer battalion and the truck company of the headquarters battalion. The CSS capabilities of all division units and a list of significant major items (class VII) of equipment are contained in this section.

4002. Headquarters Battalion, Marine Division

a. Mission and Organization

The primary mission of the headquarters battalion is to exercise command, control, and administration of the Marine division. (See figure 4-2.)

It contains an H&S company, a division headquarters with an H&S company, a reconnaissance company, a special security communications team, a communications company, a military police (MP) company, the division band, and a truck company.

- w The H&S Company provides command, administrative, and security functions as well as organic supply for the headquarters battalion.
- w The Reconnaissance Company provides ground reconnaissance and surveillance in support of the division or its subordinate elements. The company consists of a company headquarters section and six reconnaissance platoons. Employment of the company emphasizes directed reconnaissance rather than passive surveillance.
- w The MP Company provides route reconnaissance, evacuation and control of enemy prisoners of war (EPW), beach and perimeter defense, area security, crowd control, and investigative services.
- w The Communications Company installs, operates, and maintains communications facilities for the division headquarters, including multichannel radio, wire, and communications center facilities.
- w The Truck Company provides general support motor transport to the Marine division.

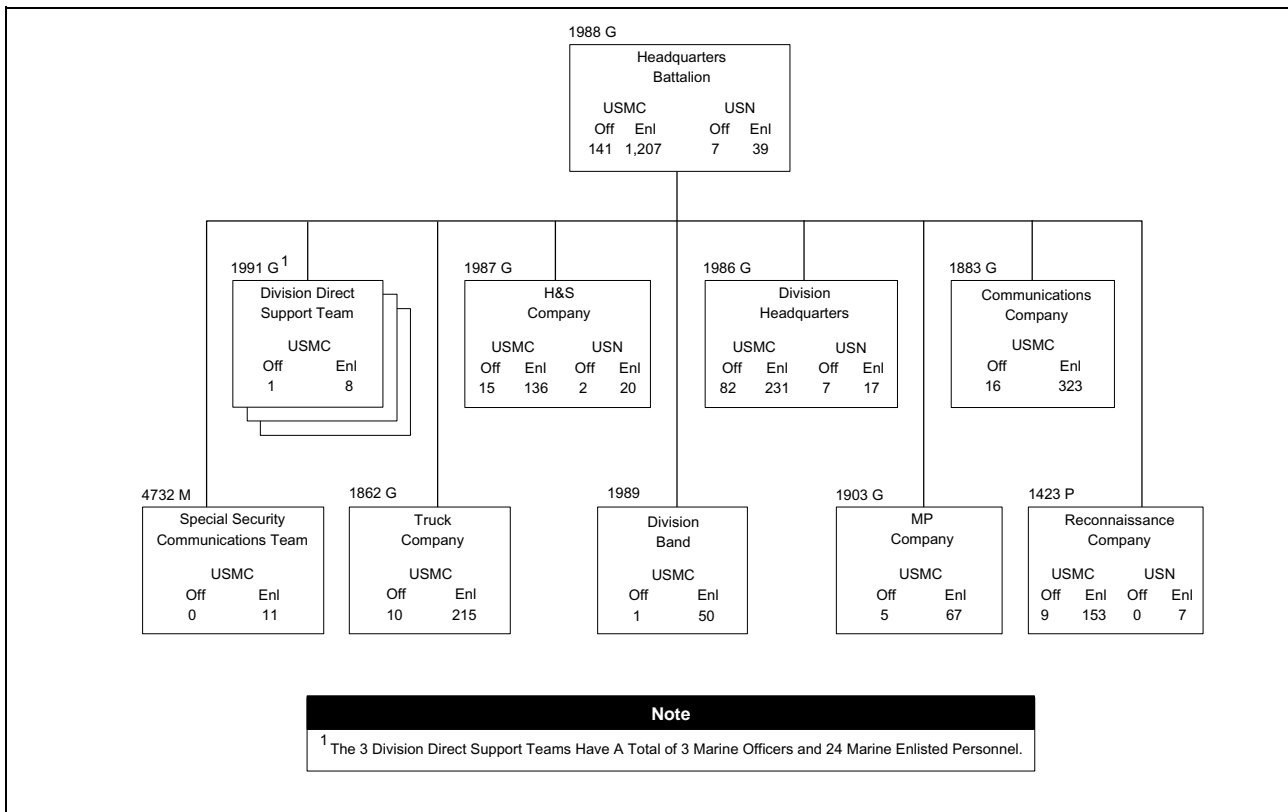

Figure 4-2. Headquarters Battalion.

b. Logistic Capabilities (Except for the Truck Company)

(1) Administrative Capability. The headquarters battalion is capable of self-administration.

(2) Maintenance. Each company is capable of organizational (1st echelon) maintenance on assigned equipment. The service company provides organizational (2d echelon) maintenance on battalion motor transport, engineering, and ordnance equipment. Organizational (2d echelon) and intermediate (3d echelon) maintenance on communications-electronics equipment is provided by the communications company. Organizational and intermediate (3d echelon) maintenance on open- and closed-circuit self-contained underwater breathing apparatus (SCUBA) equipment and boats is provided by the reconnaissance company.

(3) Supply. The service company operates the organic supply account for the battalion.

(4) Medical. The medical section of the headquarters company provides for emergency treatment and preparation for evacuation of all casualties, treats minor illness and injuries, and supervises disease prevention and control measures for the battalion.

(5) Transportation. The battalion has the organic transportation capability that is required to support its mission. The service company provides motor transport support to

augment the organic capabilities of the companies of the battalion, as required.

(6) Messing. The messing section of the service company provides food service support to the battalion.

4003. Infantry Regiment, Marine Division

a. Mission

The primary mission of the infantry regiment is to locate, close with, and destroy the enemy by fire and maneuver or to repel his assault by fire and close combat.

b. Concept of Organization

The infantry regiment consists of a headquarters company and two or more infantry battalions (normally three infantry battalions). (See figure 4-3.) The infantry battalions are the basic tactical units with which the regiment accomplishes its mission. The headquarters company of the infantry regiment contains a regimental headquarters and a reconnaissance platoon. When combined with other combat support and CSS units, it will form a regimental landing team. Command and staff functions for the regiment are exercised through a compact operational command group that consists of the commander and an executive staff. The staff is capable of integrating the efforts of attached units with those of supporting units. The staff can support a tactical, main, and rear command echelon during displacement. The basic means of ground mobility of the regiment is by foot, supplemented by

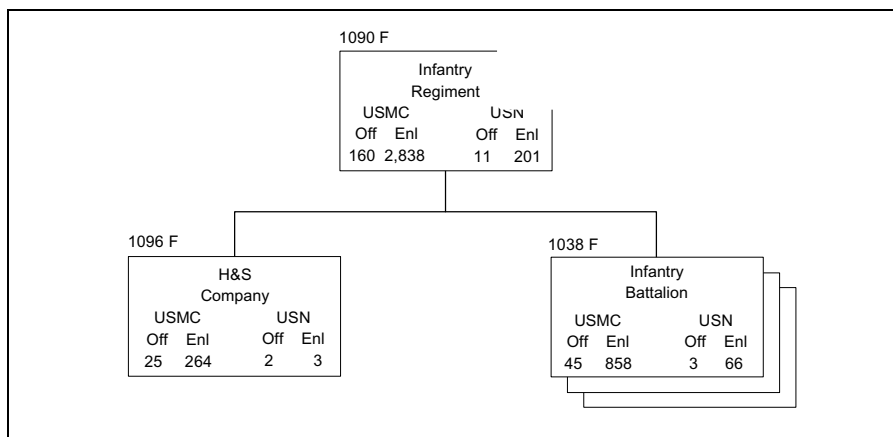

Figure 4-3. Infantry Regiment.

small, lightweight vehicles for transportation of electronic equipment, weapons, and limited amounts of ammunition and supplies. All elements are helicopter transportable and compatible with other means of transportation (e.g., assault amphibious vehicles (AAVs), motor transport, fixed-wing aircraft, and ships).

c. Concept of Employment

The infantry regiment is the major element of close combat power of the Marine division. (See figure 4-4.) The regiment, with appropriate attachments, is capable of independent, sustained operations.

d. Logistic Capabilities

The following logistic capabilities are those of the headquarters company and the infantry regiment and its individual battalions. The regiment's total capability is the sum of the capabilities of its subordinate units.

(1) Administrative Capability. The regiment is capable of self-administration.

(2) Maintenance. The regiment is capable of 1st and 2d echelon maintenance on all organic equipment.

(3) Supply. Regiment supply is capable of providing organic supply support for the regiment. Generally, unit distribution is the preferred method of supply, but supply point distribution may also be used.

(4) Medical. The regiment medical platoon provides preventive medicine, treatment for minor illnesses and injuries, and emergency lifesaving for battle and nonbattle casualties. Injured and sick persons requiring hospitalization are readied and evacuated to the rear. Normally, a regiment aid station (RAS) serves as the hub for medical support. Headquarters company medical personnel provide emergency treatment and preparation for evacuation for the company.

(5) Transportation. High-mobility, multipurpose wheeled vehicles (HMMWVs) provide organic transportation for the infantry.

(6) Messing. The infantry regiment is capable of organic food service support.

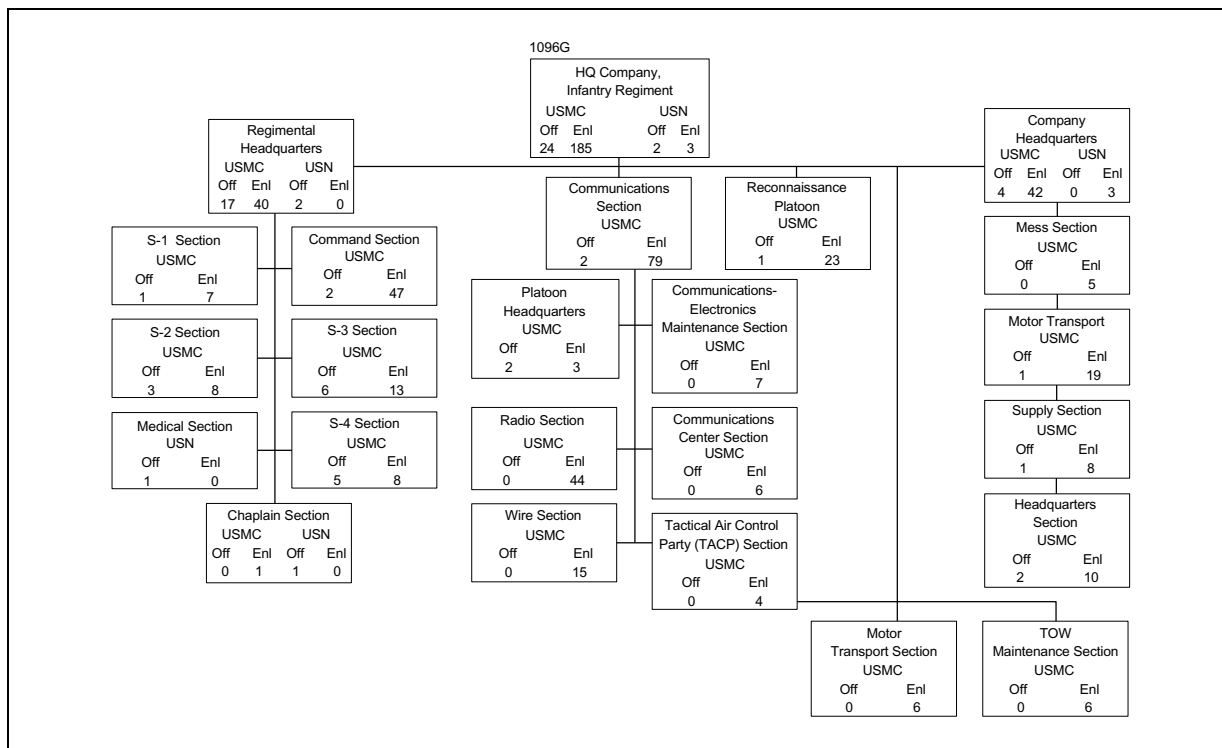

Figure 4-4. HQ Company, Infantry Regiment.

TAM Number	Item	Quantity	
		Infantry Battalion	Headquarters Company
		(Each)	Infantry Regiment (Each)
A0662	FMF end-user computer	13	13
A0815	Heliport lighting set	1	1
A1530	Radar transponder beacon, AN/PPN-19	2	4
A1815	Radio set, AN/GRC 160	21	43
A1930	Radio set, AN/MRC 110A	5	5
A1935	Radio set, AN/MRC 138A	3	5
A1957	Radio set, AN/MRC 145	5	7
A2030	Radio set, AN/PRC 68A	94	6
A2050	Radio set, AN/PRC 119	72	21
A2051	Radio set, position location reporting system (PLRS)	15	6
A2065	Radio set, AN/PRC 104(B)	5	5
A2069	Radio set, VHF, AN/PRC 113	5	2
A2070	Radio set, PRC 119	58	11
B0730	Generator set, 3 kW, 60 Hz, MEP 016B	1	2
B1650	Refrigeration unit, 100 ft ³	2	2
D1002	Truck, ambulance, two litter, 1/4 ton, HMMWV, M1035	2	1
D1016	Truck, cargo, 1 1/4 ton, diesel, 4 x 4, M1008	4	3
D1158	Truck, utility, cargo troop carrier, 1 1/4 ton, M998	27	12
D1159	Truck, utility, armament carrier, M1043	10	
E0892	Launcher, grenade, 40 mm, M203	107	0
E0310	Dragon day/night tracker	12	0
E0915	Launcher, assault rocket, 83 mm, MK153 (SMAW)	18	0
E0935	TOW launcher	8	
E0960	Machine gun, light squad, M249	81	6
E0980	Machine gun, .50 cal	6	0
E0980	Machine gun, 7.62 mm, 240G		29
E0994	Machine gun, 40 mm, MK14	11	8
E1065	Mortar, 60 mm, M224	9	0
E1090	Mortar, infantry, 81 mm, M252 8	0	
H2045	Antenna, RC292	12	15
H2442	Telephone set, TA-1/PT	44	12
H2443	Telephone set, TA-312/PT	35	36

Table 4-1. Selected Items of Equipment for the Infantry Regiment/Battalion.

(7) Selected Items of Equipment. For a list of selected items of equipment, see table 4-1.

4004. Infantry Battalion, Infantry Regiment

a. Mission

The primary mission of the infantry battalion is to locate, close with, and destroy the enemy by fire and maneuver or to repel his assault by fire and close combat.

b. Concept of Organization

The infantry battalion structure is shown in figure 4-5 on page 4-6.

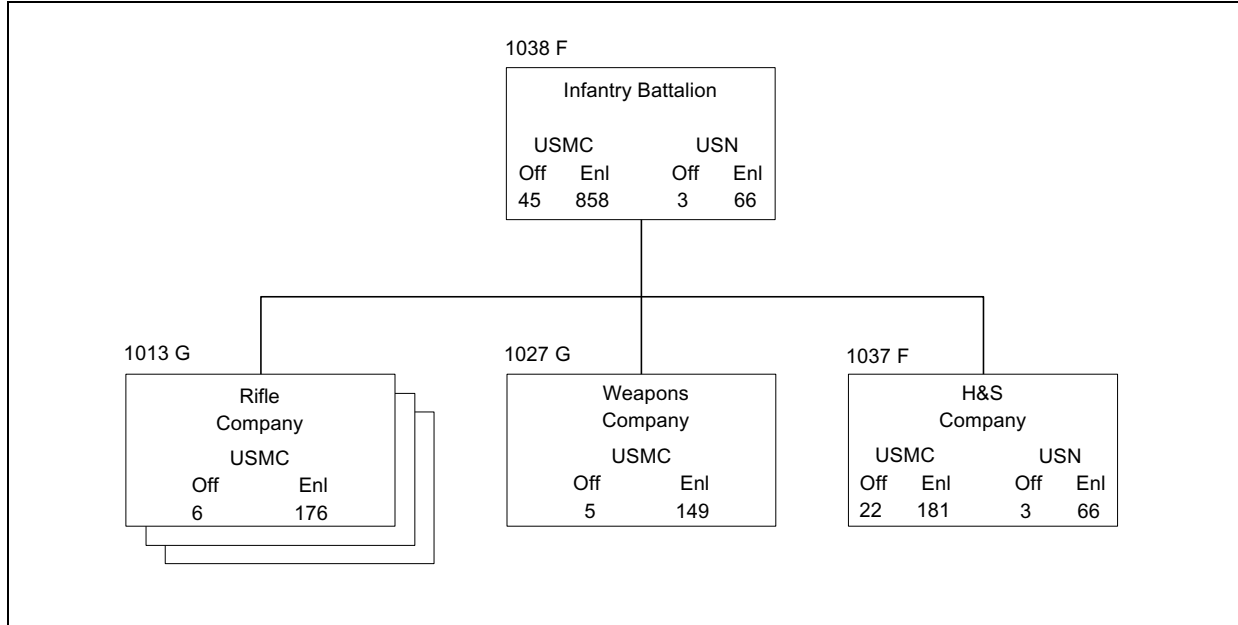

Figure 4-5. Infantry Battalion, Infantry Regiment (Three Rifle Companies).

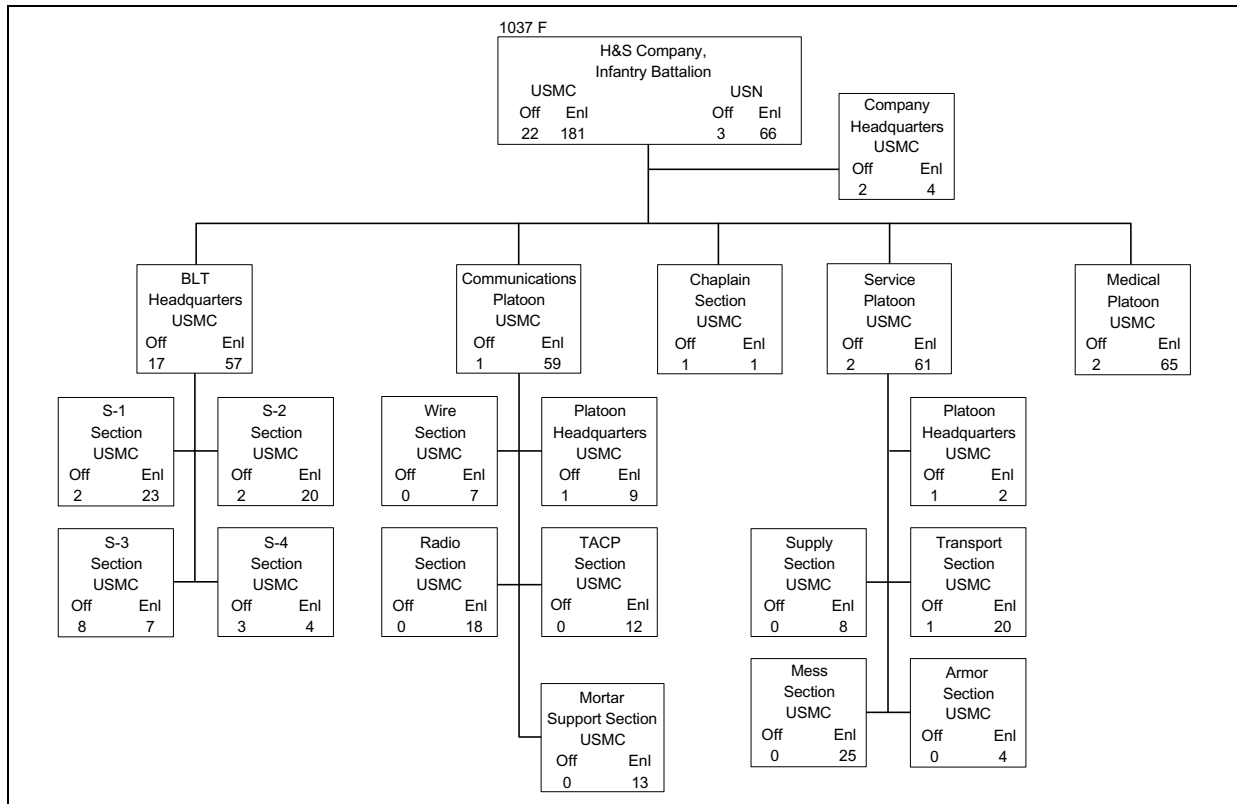

Figure 4-6. H&S Company, Infantry Battalion.

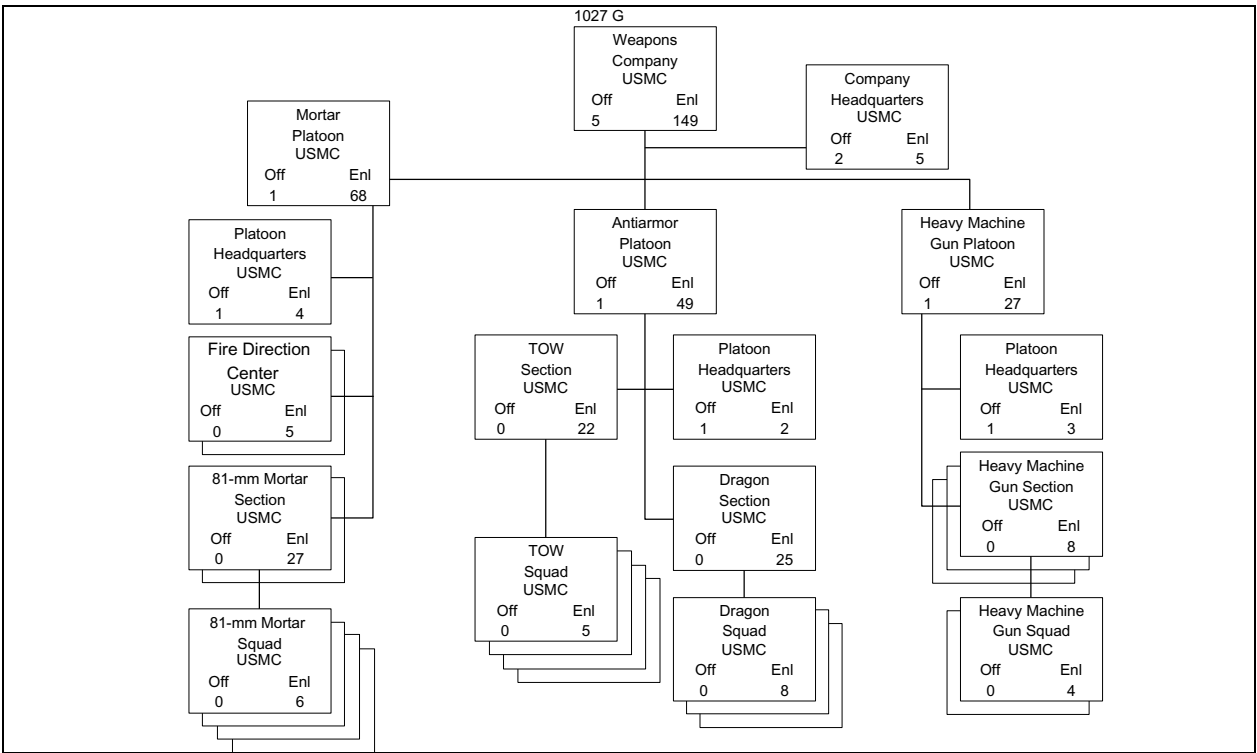

Figure 4-7. Weapons Company.

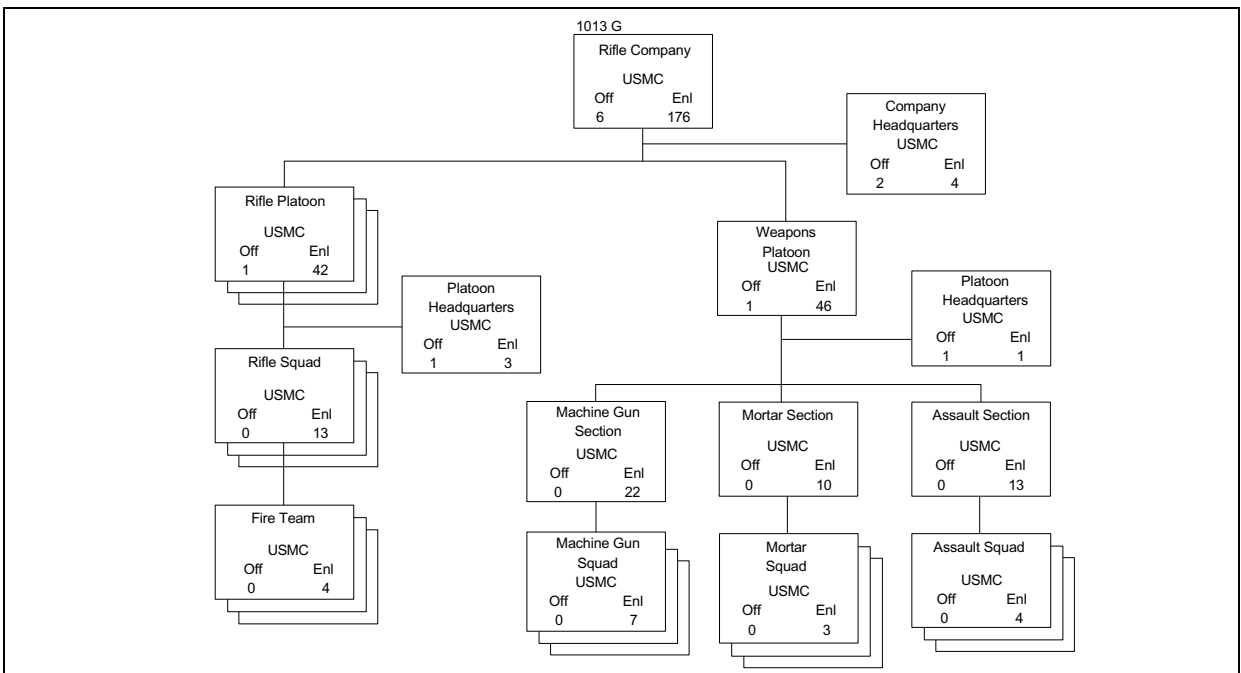

Figure 4-8. Rifle Company.

(1) Infantry Battalion. The infantry battalion consists of an H&S company, a weapons company, and three rifle companies. (See figure 4-6 on page 4-6, figure 4-7 on page 4-7, and figure 4-8 on page 4-7.) The rifle companies are the basic tactical units with which the battalion accomplishes its mission. When the battalion is combined with combat support and CSS units, it forms a battalion landing team (BLT).

(2) Command and Staff Functions. Command and staff functions are exercised through a compact operational command group that consists of the commander and his executive staff. The staff is capable of integrating the efforts of attached units with those of supporting units by using representatives of these elements provided for that purpose. The staff is capable of supporting a tactical and main echelon and alternatives during displacement. All fire in support of the battalion is coordinated by the weapons company commander, who functions as the battalion fire support coordinator under the staff cognizance of the operations officer.

(3) Battalion Firepower. In addition to individual weapons, the organic battalion firepower consists of light, medium, and heavy machine guns; light and medium mortars; and light and medium antiarmor weapons that are capable of supporting the rifle companies.

(4) Mobility. The basic means of mobility is by foot, supplemented by use of organic, small, lightweight vehicles for the transportation of electronics equipment, weapons, and limited amounts of ammunition and supplies. All elements are helicopter transportable and are compatible with other means of transportation (e.g., AAVs, motor transport, fixed-wing aircraft, and ships).

(5) Logistic Capability. Logistic capability is compatible with the mobility and combat power of the battalion. The battalion is structured on the basis of unit distribution of supplies within the battalion.

(6) Total Weapons in the Infantry Battalion. For a complete list of infantry battalion weapons, see table 4-2.

(7) Weapon Distribution. Within the rifle company, the fire team leader carries an M16A2 rifle and an M203 grenade launcher. The squad automatic rifleman carries the M249 squad automatic weapon (SAW); all other riflemen, including the assistant automatic rifleman, carry an M16A2. Squad leaders and the officers and enlisted personnel of the platoon headquarters carry M16A2 rifles.

The weapons platoon machine gun section has six M240G machine guns, the mortar section has three M224 60-mm mortars, and the assault section has six MK153 83-mm

Weapon	Series F (Three Rifle Companies)
M9 9-mm pistol	245
M16A2 rifle	645
M203 grenade launcher	107
MK153 SMAW 18	
M249 SAW	81
M240G machine gun	29
M2 .50-cal machine gun	6
MK19 40-mm grenade machine gun	11
M47 Dragon (antitank weapon)	12
M224 60-mm mortar	9
M252 81-mm mortar	8
M40A1 Sniper rifle, 7.62 mm	8
TOW	8

Table 4-2. Infantry Battalion Weapons.

shoulder-launched multipurpose assault weapons (SMAWs).

The weapons company mortar platoon has 8 M252 81-mm mortars, the antiarmor platoon has 12 M47 Dragons, and its tube-launched, optically tracked, wire command link guided missile (TOW) section has 8 TOWs.

The heavy machine gun platoon has six each of M2 .50-cal machine guns and MK19 40-mm grenade machine guns.

c. Concept of Employment

The battalion is the basic tactical unit of ground combat power and the nucleus of the BLT. As a balanced firepower and maneuver team, it attacks and destroys all targets in the assigned area of responsibility. With detachments, it is capable of independent, sustained operations for a period of several days as permitted by combat conditions. It is capable of conducting a coordinated deliberate defense.

d. Logistic Capabilities

For information on logistic capabilities, see paragraph 4003.d. For selected items of equipment, see table 4-1 on page 4-5.

4005. Artillery Regiment, Marine Division

a. Mission

The mission of artillery in the Marine division is to furnish close and continuous fire support by neutralizing, destroying, or suppressing targets that threaten the success of the supported unit.

b. Concept of Organization

All artillery regiments have a headquarters battery. There are four artillery battalions in the 10th and 11th Marine Regiments and two in the 12th Marine Regiment. (See figure 4-9.) Each of these battalions is capable of performing the responsibilities associated with any of the four standard artillery tactical missions. Artillery regimental functions are discharged through a command group, which consists of the commander and executive staff, augmented by sufficient technical personnel. The staff is capable of integrating the efforts of any attached, reinforcing, or supporting units. The staff is capable of supporting a tactical, main, and rear command echelon during displacements and, when augmented, can operate as an alternate division COC for short periods of time. The basic means of ground mobility is

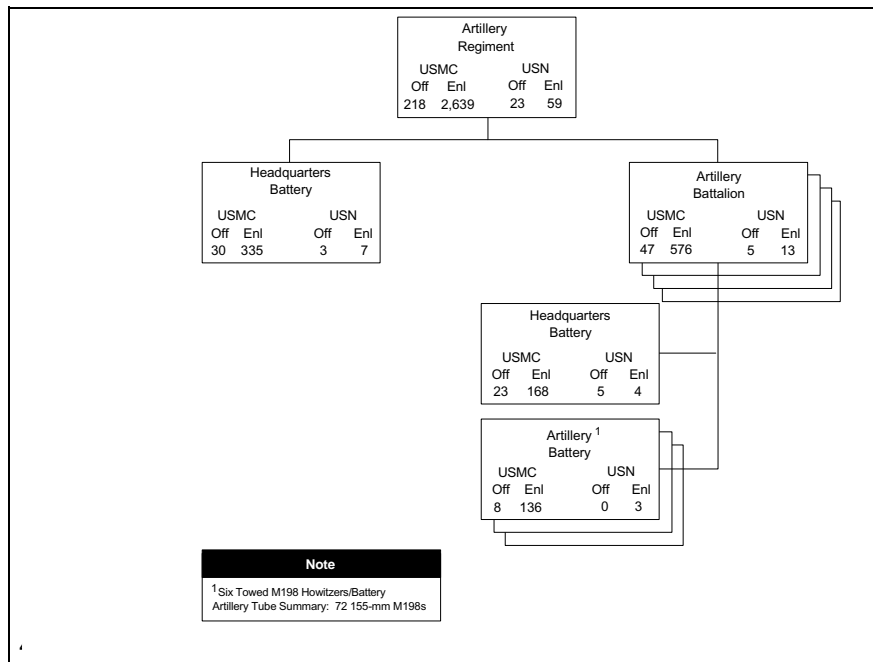

Figure 4-9. Artillery Regiment.

organic vehicular transportation. All CEs and some fire support assets are helicopter transportable. With the M198 weapons system, helicopterborne mobility is severely limited.

c. Concept of Employment

The artillery regiment is the primary source of fire support for the Marine division. Its operations and actions are closely integrated with those of the infantry to be responsive to rapidly changing tactical situations. The artillery regiment provides a fire support coordination section to assist in establishing and operating an FSCC at the division COC.

d. Target Acquisition

Each regiment is equipped with a counterbattery radar platoon that is capable of locating enemy indirect-fire weapons within the division's sector. The platoon has five AN/TPQ-46A counterbattery radars.

e. Logistic Capabilities

The logistic capabilities that follow cover the capabilities of the headquarters battery, the artillery regiment, and the individual artillery battalions. The total logistic capability of the regiment is the sum of the capabilities of its subordinate units.

(1) Administrative Capabilities. The artillery regiment is capable of self-administration.

(2) Maintenance. The artillery regiment performs organizational (1st and 2d echelon) maintenance on all equipment (except fire control). The headquarters battery of the artillery regiment performs intermediate (3d and 4th echelon) maintenance on electronics systems within the command and performs intermediate (4th echelon) maintenance on weapons-loading radar equipment.

(3) Supply. Artillery units perform all supply functions to some degree. Supply operations are performed in each class of supply, with particular emphasis on classes I, III, V, and IX. External supply support is obtained from the CSSE.

(4) Health Services. Medical personnel provide emergency treatment and preparation for evacuation of all casualties, treat minor illnesses and injuries, and supervise disease prevention and control measures.

(5) Transportation. The organic transportation assets of the artillery unit provide the necessary mobility to deliver continuous artillery support. Artillery units are capable of moving their personnel, equipment, and a limited quantity of supplies. Organic vehicles consist of wheeled vehicles. Artillery is capable of being transported by landing craft, transport aircraft, and, to a limited extent, helicopters.

(6) Messing. The headquarters battery is capable of operating a battery mess hall. The battalions can operate a battalion mess hall.

(7) Selected Items of Equipment. The composition of artillery battalions varies in I, II, and III MEF. The equipment list in table 4-3 is provided for planning purposes and is divided by the type of battery that the equipment supports. For a list of equipment for a specific unit, refer to the appropriate T/E.

4006. Artillery Battalion, Artillery Regiment

a. Mission

The mission of the artillery battalion in the Marine division is to furnish close and continuous fire support by neutralizing, destroying, or suppressing targets that threaten the success of the supported unit.

b. Concept of Organization

An artillery battalion consists of a headquarters battery and firing batteries. The headquarters battery provides the equipment and personnel to assist the battalion commander in controlling and supporting his battalion. Like the regiment, the battalion headquarters may be employed in a main or rear echelon configuration. Artillery battalions have three or four firing batteries of six howitzers. Marine artillery currently employs the M198, 155mm towed howitzer.

c. Concept of Employment

The artillery battalion is the basic tactical unit of the artillery. It has enough firing units to effectively mass its fires and to engage several targets simultaneously. The battalion is normally employed as a unit to meet the fire support requirements that are defined by its assigned tactical mission. The battalion maintains communications with its batteries and any attachments, the supported/reinforced units, and the artillery regiment as appropriate. When a battalion deploys

TAM Number	Item	Quantity		
		Headquarters Battery, Regiment	Headquarters Battery, Battalion	155 M198 Battery
A1935	Radio set, AN/MRC 138	9	5	
A1955	Radio set, AN/MRC 142	4		
A2190	Radar set, firefinder, AN/TPQ-46A	5		
A1957	Radio set, AN/MRC 145	9	6	4
B0730	Generator set, 3 kW, 60 Hz, MEP-016A	50		
B0891	Generator set, 10 kW, 60 Hz, MEP-003A	12		
B0921	Generator set, 10 kW, 60 Hz, MEP-112A	10		
B0953	Generator set, 10 kW, 60 Hz, MEP-005A	10		
B1021	Generator set, 10 kW, 60 Hz, MEP-006A	6		
B2462	Tractor, medium, full tracked, 82-30		6	
B2464	Tractor, full tracked, MC-1150E	4		
B2566	Truck, forklift	8	2	1
D0230	Semitrailer, low bed, 40 ton, M870A1	3		
D0860	Trailer, cargo, 1 1/2 ton, M105A2	25	2	8
D1059	Truck, cargo, 5 ton, M923	57	10	16
D1158	Truck, utility, 1 1/4 ton, M998	45	18	5
D1212	Truck, wrecker, 5 ton, M936	2	2	
E0665	Howitzer, med, towed, 155mm, M198			6

Table 4-3. Selected Items of Equipment for the Artillery Regiment.

independently, it is augmented with appropriate support from the regiment; for example, the meteorological section.

d. Logistic Capabilities

For logistic capabilities, see paragraph 4005.e.

4007. Tank Battalion, Marine Division

a. Mission

The mission of the tank battalion is to close with and destroy the enemy by using armor-protected firepower, shock effect, and maneuver and to provide antimechanized fire in support of the Marine division.

b. Concept of Organization

A typical tank battalion consists of an H&S company, one antitank platoon, and four tank companies. The tank companies are the basic tactical unit with which the battalion accomplishes its mission. The antitank platoon provides antimechanized support to the division. (See figure 4-10 on

page 4-12.) The tank battalion has 58 M1A1 tanks (with 120-mm guns), 26 TOW weapons systems, and 5 M88A1 tank recovery vehicles.

c. Concept of Employment

The battalion is best employed as a maneuver force without detaching units. However, the division commander may task organize forces of tanks, mechanized infantry, and other division resources based on mission, enemy, terrain and weather, troops and support available-time available (METT-T) that require cross-attachment of tank battalion and infantry regiment assets. Employment of the tank battalion must take advantage of the speed, mobility, and firepower of the organization.

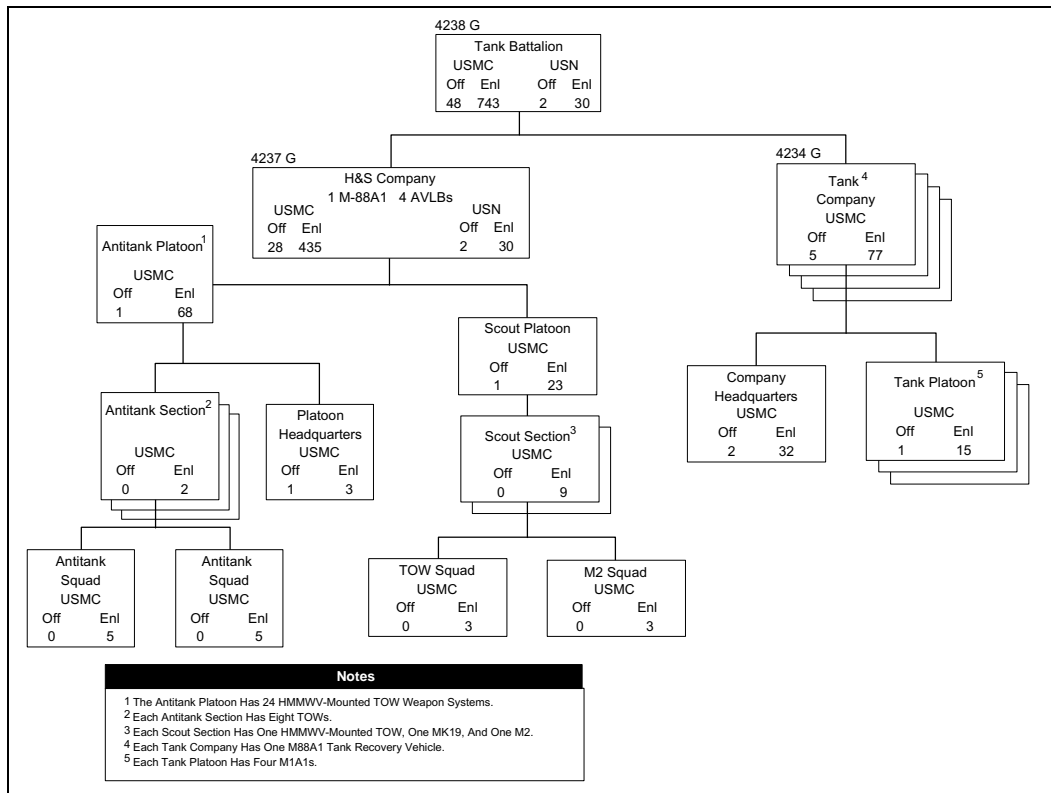

Figure 4-10. Tank Battalion.

d. Logistic Capabilities

(1) Administrative Capability. The tank battalion is capable of self-administration.

(2) Maintenance. All companies are capable of organizational (1st echelon and 2d echelon) maintenance on all equipment that is organic to the companies. The only exception to this is the tank company, which requires 2d echelon maintenance support for motor transport items. Intermediate (3d echelon) maintenance is performed by the H&S company on tanks, tank-mounted weapons, and very high frequency (VHF) equipment and its associated cabling and auxiliary audio equipment that is organic to the battalion. 3d echelon maintenance on TOW missile systems is performed by the antitank platoon.

(3) Supply. The tank battalion is capable of organic supply functions for the battalion. It maintains, within the battalion supply platoon, a limited level of supply for the companies.

(4) Medical. The tank battalion provides emergency treatment and prepares for evacuation by external means of all casualties within the battalion that require hospitalization. It also provides a field dispensary for treatment of minor illnesses and exercises technical supervision of measures for the prevention and control of disease.

(5) Transportation. Transportation means that are organic to the battalion consist of a sufficient number of trucks and small general-purpose vehicles for command, communications, medical, and high-usage resupply.

(6) Messing. The tank battalion is capable of organic food service support.

(7) Selected Items of Equipment. See table 4-4 for tank battalion selected items of equipment.

TAM		
Number	Item	Quantity
A1930	Radio set, MRC110A	5
A1935	Radio set, MRC 138A	3
B1580	Pump module (fuel)	12
B1581	Pump module,	6
B2085	Storage tank, fuel, 900-gal capacity	24
B2086	Storage tank, water, 900-gal capacity	12
B0730	Generator set, 3 kW, 60 Hz, MEP-016A	4
B0891	Generator set, 10 kW, 60 Hz, MEP-803A	4
B0953	Generator set, 30 kW, 60 Hz, MEP-005A	3
B2561	Truck, forklift	1
B2685	Welding machine, arc	2
D0860	Trailer, cargo, 1 1/2 ton, M105A2	21
D0875	Trailer, flatbed, 22 1/2 ton, M14	8
D0880	Trailer, tank, water, 400 gal, M149A1	9
D1002	Truck, ambulance, 1 1/4 ton, HMMWV, M1035	9
D1059	Truck, cargo, 5 ton, M923	38
D1125	Truck, TOW carrier with equipment, HMMWV, M1045	26
D1158	Truck, utility, 1 1/4 ton, M998	52
D1212	Truck, wrecker, M936	2
E0149	Bridge scissor for armored vehicle-launched bridge (AVLB)	6
E0150	Bridge, armored vehicle launched, M60A1	4
E1377	Recovery vehicle, full tracked, M88A2	12
E1888	Tank, combat, FT, 120mm gun, M1A1	58

Table 4-4. Selected Items of Equipment for the Tank Battalion.

4008. Assault Amphibian Battalion, Marine Division

a. Mission

The mission of the assault amphibian battalion is to land the surface assault elements of the landing force and their equipment in a single lift from assault shipping during amphibious operations to inland objectives and to conduct mechanized operations and related combat support in subsequent operations ashore.

b. Concepts of Organization

The battalion is organized with an H&S company and four assault amphibian companies. (See figure 4-11 on page 4-14.) The organization of the assault amphibian company permits independent deployment for limited operations.

c. Concept of Employment

The battalion and its subordinate units are assigned to or in support of a MAGTF to provide ship-to-shore lift capability during the amphibious assault. During operations ashore, the battalion elements provide mobility equal to that of tanks to the assaulting elements of the MAGTF. AAVs are primarily used to transport personnel in tactical operations. If assets permit, they may be used as cargo carriers forward of the forward edge of the battle area (FEBA).

d. Logistic Capabilities

(1) Administrative Capability. The assault amphibian battalion is capable of self-administration.

(2) Maintenance. The assault amphibian battalion is capable of organizational maintenance (1st and 2d echelon) on all equipment organic to the battalion and intermediate

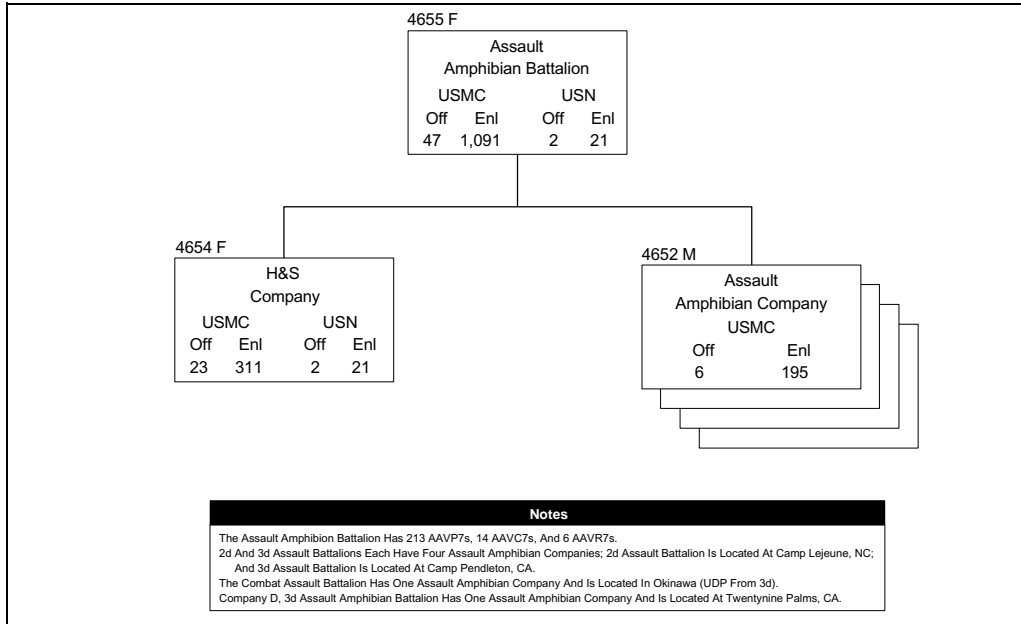

Figure 4-11. Assault Amphibian Battalion.

maintenance (3d echelon) on AAVs and their mounted weapons and VHF equipment and its associated cabling and auxiliary audio equipment that is organic to the battalion.

(3) Supply. The assault amphibian battalion maintains operation/training repair parts and supplies as directed.

(4) Selected Items of Equipment. See table 4-5 for assault amphibian battalion selected items of equipment.

4009. Combat Engineer Battalion, Marine Division

a. Mission and Tasks

(1) Mission. The mission of the combat engineer battalion is to enhance the mobility, countermobility, and survivability of the Marine division through close combat engineer support and to provide the limited general engineering

TAM Number	Item	Quantity
B0891	Generator set, 10 kW, 60 Hz, MEP-003A	6
B0953	Generator set, 30 kW, 60 Hz, MEP-005A	2
B1021	Generator set, 60 kW, 60 Hz, MEP-006A	1
B2685	Welding machine, arc, trailer mounted, 353-T	5
D0860	Trailer, cargo, 1 1/2 ton, M105A2	3
D0876	Trailer, powered, 22 1/2 ton, M14	6
D0880	Trailer, tank, water, 400 gal, M149A1	11
D1059	Truck, cargo, 5 ton, M923A1	22
D1158	Truck, utility, 1 1/4 ton, M998	26
D1212	Truck, wrecker, M936	1
E0796	AAV, AAVC7A1	14
E0846	AAV, AAVP7A1	213
E0856	AAV, AAVR7A1	6

Table 4-5. Selected Items of Equipment for the Assault Amphibian Battalion.

support that is required for the functioning of the Marine division.

(2) Tasks

(a) Mobility Tasks

- w Conduct engineer reconnaissance and support intelligence collection within the division zone or sector. In areas not under division control, support will be required when conducting this reconnaissance. Provide personnel to augment other division elements conducting reconnaissance missions that include requirements for engineer intelligence.
- w Plan, organize, and coordinate the assault breaching of explosive and nonexplosive obstacles from the high-water mark inland.
- w Employ assault bridge systems. When augmented, employ other standard bridge systems.
- w Provide expedient repair and reinforcement of existing bridges.
- w Construct expedient, short-span bridges from local materials in support of ground combat operations.
- w Provide temporary repair of existing roads and limited new construction of combat roads and trails, including the maintenance that is necessary to support combat operations of the division.

(b) Countermobility Tasks

- w Plan, organize, and coordinate the construction of simple and compound explosive and nonexplosive obstacle systems.
- w Plan and construct obstacles that require special engineering equipment and technical skills.
- w Perform specialized demolition missions that are beyond the capability of other division units.

(c) Survivability Task. The combat engineer battalion should provide technical assistance and the necessary equipment for the development of temporary protective positions for personnel and equipment.

(d) General Engineering Support Tasks

- w Provide essential construction support that is temporary and designed to meet minimum combat requirements.
- w Provide utility support, including mobile electric power equipment and potable water for essential troop consumption, bath services, and equipment operational and maintenance requirements.
- w Construct and improve expedient VTOL sites in support of division operations.

b. Concept of Organization

The combat engineer battalion consists of an H&S company, an engineer support company, and four combat engineer companies. (See figure 4-12.) The H&S company consists of elements that provide the battalion commander with facilities for command and control functions and communications support for subordinate elements of the

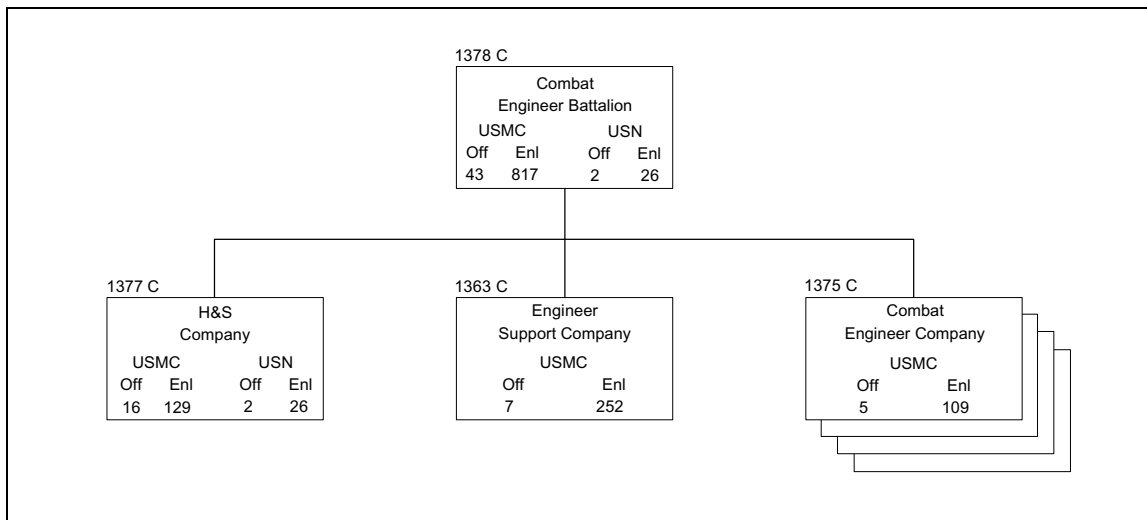

Figure 4-12. Combat Engineer Battalion.

battalion. The engineer support company consists of a company headquarters, an engineer equipment platoon, a utilities platoon, and a motor transport platoon. Four combat engineer companies are included in the battalion organization to provide support to infantry regiments and other division units, as required. Each of the combat engineer companies consists of a company headquarters and three combat engineer platoons.

(1) Command and Control. The battalion commanding officer exercises command and control through the battalion staff and company commanders.

(2) Firepower. Firepower is limited to light infantry weapons.

(3) Mobility. The combat engineer battalion is not self-mobile. It requires external motor transport to move the battalion as a unit and requires transport by support maneuver units to provide comparable mobility and survivability.

c. Concept of Employment

The combat engineer battalion provides close combat support and limited general engineer support for the division through task-organized combat engineer elements for GCE units. Operation of those elements supporting forward units is generally decentralized. Engineer support requirements to the rear of forward elements will be performed under centralized engineer battalion control. The engineer support company provides augmentation in the form of personnel and specialized engineering equipment to the combat engineer companies.

d. Administrative Capability

The combat engineer battalion is capable of self-administration.

e. Logistic Capabilities

(1) Maintenance

(a) Organic. The combat engineer battalion is capable of organizational (1st echelon) maintenance on all assigned equipment. The battalion is capable of 2d echelon maintenance on all equipment listed in table 4-6. Intermediate (3d and 4th echelon) maintenance is provided by the maintenance battalion of the FSSG.

(b) Support. The combat engineer battalion receives no external maintenance support.

(2) Supply. The combat engineer battalion is capable of providing organic supply to the battalion.

(3) Medical. The combat engineer battalion is capable of providing medical service support to the battalion.

(4) Transportation. The battalion has limited organic transportation capability. It requires external motor transport support to move the battalion as a unit and requires transport by supported maneuver units to provide comparable mobility and survivability.

(5) Messing. The combat engineer battalion is capable of organic food service support.

4010. H&S Company, Combat Engineer Battalion

a. Mission

The mission of the H&S company is to provide command, control, and administrative elements to supervise the operations of the battalion, including the provision of supply, food services, communications, chaplain services, administration, and medical support.

b. Concept of Organization

The H&S company consists of the battalion headquarters, which contains a headquarters section, an S-1/adjutant section, an S-2 section, an S-3 section, and an S-4 section; a supply platoon; a mess section; a communications platoon; a medical section; a chaplain section; and a company headquarters. (See figure 4-13.)

(1) Command and Control. The company provides the battalion commander with facilities for command and control. The company commander executes the normal command and staff functions.

(2) Firepower. Firepower is limited to light infantry weapons and crew-served machine guns.

(3) Communications. The H&S company is capable of providing communications support for the battalion.

TAM		
Number	Item	Quantity
A1815	Radio set, AN/GRC-160	6
A1930	Radio set, AN/MRC 110A	3
A1935	Radio set, AN/MRC 138B	6
A2050	Radio set, AN/PRC-77	13
A2065	Radio set, AN/PRC-104B	5
A2151	Radio set, vehicle, AN/SQ-1	1
A2480	Switchboard, telephone, manual, B-22/pt	3
A2167	Radio set, vehicle, AN/R88A	10
A2505	Switchboard, telephone, automatic, SB-3614(V)TT	1
A2635	Telephone set, TA-838_/_/TT	18
A2685	Terminal, telegraph/telephone, TH-85A/GCC	2
B0475	Detecting set, mine, portable, metal, AN/PSS12	2
B1298	Line charge launch kit	2
B1645	Refrigeration unit	2
B2119	Surveying set, general purpose	1
D1002	Truck, ambulance, two litter, M1035	1
D1158	Truck, utility, cargo, 1 1/4 ton, M998	2

Table 4-6. Selected Items of Equipment for the

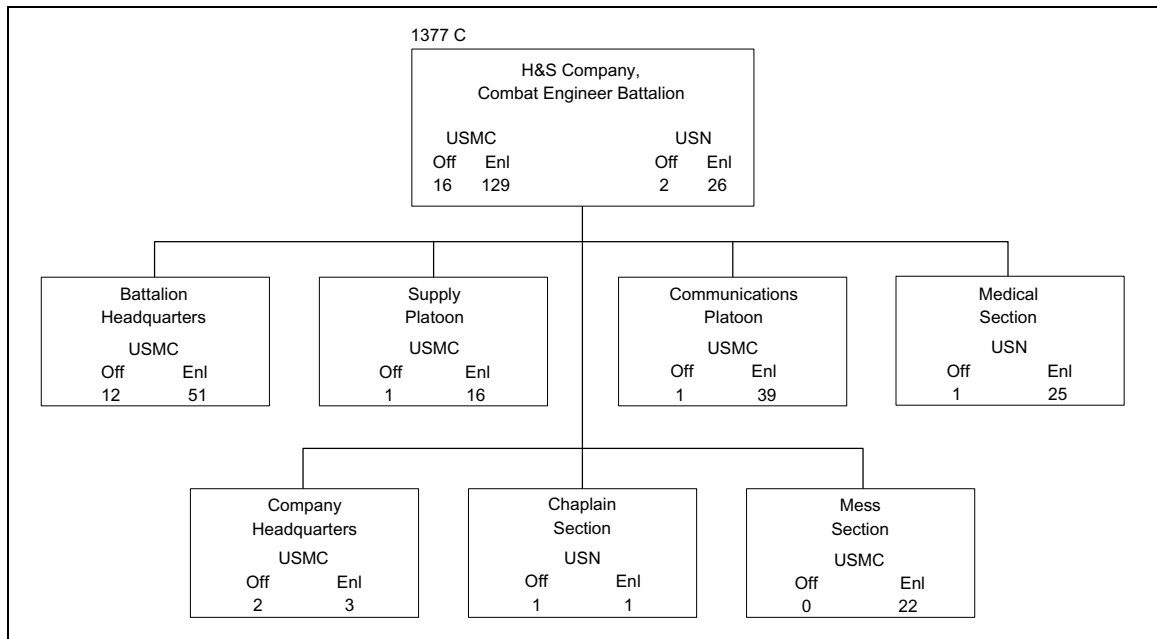

Figure 4-13. H&S Company, Combat Engineer Battalion.

(4) Mobility. The H&S company is not self-mobile. It requires motor transport support from external sources to move the company as a unit.

c. Concept of Employment

The company decentralizes support functions in the area of supply, messing, communications, medical, and chaplain services to the extent necessary to meet battalion operational requirements. It provides internal supply, communications, medical, and messing support to subordinate elements of the battalion.

d. Administrative Capability

Administrative support is provided at the battalion level.

e. Logistic Capabilities

(1) Maintenance

(a) Organic. The H&S company is capable of organizational (1st echelon) maintenance on all assigned equipment and organizational (2d echelon) maintenance on assigned communications equipment and infantry weapons. Organizational (2d echelon) maintenance on motor transport and engineering equipment is provided by the engineer support company of the engineer battalion. Intermediate (3d and 4th echelon) maintenance is provided by the maintenance battalion of the FSSG.

(b) Support. The H&S company receives no external maintenance support.

(2) Supply. The H&S company is capable of providing organic supply to the battalion.

(3) Medical. The H&S company is capable of providing medical service support to the battalion.

(4) Transportation. The H&S company has no organic transportation capability. Support is provided by the engineer support company of the combat engineer battalion.

(5) Messing. The H&S company is capable of providing food service support to the battalion.

(6) Selected Items of Equipment. For H&S company selected items of equipment, see table 4-6 on page 4-17.

4011. Engineer Support Company, Combat Engineer Battalion

a. Mission and Tasks

(1) Mission. The mission of the engineer support company is to provide personnel, equipment, and appropriate task units to other elements of the battalion in support of operational requirements and to provide minimum potable water for the Marine division and electrical power for designated elements of the Marine division.

(2) Tasks

- w Provide construction, materials handling and lifting equipment, and operators in support of other battalion elements or to perform separate mission assignments within the battalion.
- w Provide potable water and hygienic services to the Marine division.
- w Provide electrical power to division organizations that are not authorized generators and provide backup power to the division, as required.
- w Provide motor transport equipment and operations, as required, to support all battalion elements.

b. Concept of Organization

The engineer support company consists of a company headquarters, an equipment platoon, a motor transport platoon, and a utilities platoon. The functional support requirements of the company are provided by the three platoons, which are structured to permit task organization of the equipment and personnel as required. (See figure 4-14.)

(1) Command and Control. The company commander directs and controls all matters pertaining to company administration and logistic support.

(2) Firepower. Firepower is limited to light infantry weapons.

(3) Communications. The engineer support company has no organic communications capability. Support is

provided by the H&S company of the combat engineer battalion.

(4) Mobility. The engineer support company requires external motor transport support to lift the combat engineer company as a unit.

c. Concept of Employment

The engineer support company provides assistance in the accomplishment of essential engineer support functions in rear areas of the division. It also augments companies with motor transport vehicles, heavy equipment, utilities equipment operators, and support personnel when required by specific missions. When this occurs, control of the augmentation elements passes to the company requiring such assistance. The company provides motor transport for the H&S company and for operation of battalion headquarters. The desired company employment is under centralized control of the battalion commander. The company provides specialist personnel for service as individuals or for task elements tailored for specific missions. The utilities platoon provides power generation and electrical distribution, water, and bathing and decontamination facilities that are essential to division operations.

d. Administrative Capability

Administrative support is provided at the battalion level.

e. Logistic Capabilities

(1) Maintenance

(a) Organic. The engineer support company is capable of providing organizational (1st echelon) maintenance on all organic equipment and organizational (2d echelon) maintenance on battalion motor transport and engineering equipment. Intermediate (3d and 4th echelon) maintenance is provided by the maintenance battalion of the FSSG.

(b) Support. The engineer support company receives no external maintenance support.

(2) Supply. The engineer support company has no organic supply capability. Support is provided by the H&S company of the combat engineer battalion.

(3) Medical. The engineer support company has no organic medical capability. Support is provided by the H&S company of the combat engineer battalion.

(4) Transportation. The engineer support company has the organic transportation capability necessary to provide support to the combat engineer battalion and fulfill the primary mission of the company.

(5) Messing. Food service support is provided by the H&S company of the combat engineer battalion.

(6) Selected Items of Equipment. See table 4-7.

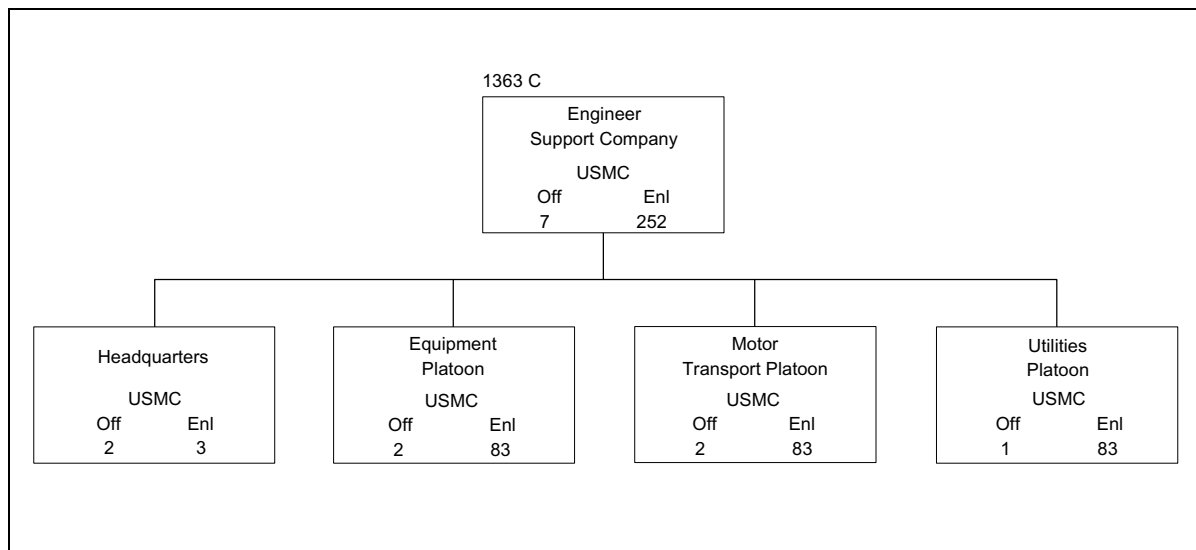

Figure 4-14. Engineer Support Company, Combat Engineer Battalion.

4012. Combat Engineer Company, Combat Engineer Battalion

a. Mission and Tasks

(1) Mission. The mission of the combat engineer company is to provide close combat support of an engineering nature as necessary to meet the essential requirements of an infantry regiment and other division elements in combat operations.

(2) Tasks

- w Provide engineer reconnaissance, as required.
- w Provide assistance for the cross-country movement of tracked and light wheeled vehicles.
- w Erect temporary engineer-type structures to assist in the movement of light vehicles and personnel across dry and wet gaps, subject to the availability of local materials.
- w Construct and operate light rafts, subject to the availability of materials.
- w Reinforce and repair existing bridges with local materials for the passage of light vehicles.
- w Improve existing terrain for use as helicopter terminal points.
- w Furnish technical assistance in the fabrication and positioning of light obstacles.
- w Supervise the emplacement of minefields and boobytraps.

- w Furnish technical and mechanical assistance in the installation of temporary cut-and-cover type field fortifications.
- w Perform specialized demolition missions that are beyond the capability of the infantryman.
- w Provide specialized assistance in breaching obstacles, including mines, from the high-water mark inland.
- w Supervise extensive or sensitive minefield clearance.
- w Perform any combat engineer related tasks when augmented with the necessary elements of the engineer support company.

b. Concept of Organization

The combat engineer company consists of a company headquarters and three combat engineer platoons. (See figure 4-15.) The company provides direct combat engineer support to infantry task groupings for operations. It can provide one combat engineer platoon for close support of each infantry battalion and associated task elements.

(1) Command and Control. The company commander directs and controls all matters pertaining to company administration and logistic support.

(2) Firepower. Firepower is limited to light infantry weapons.

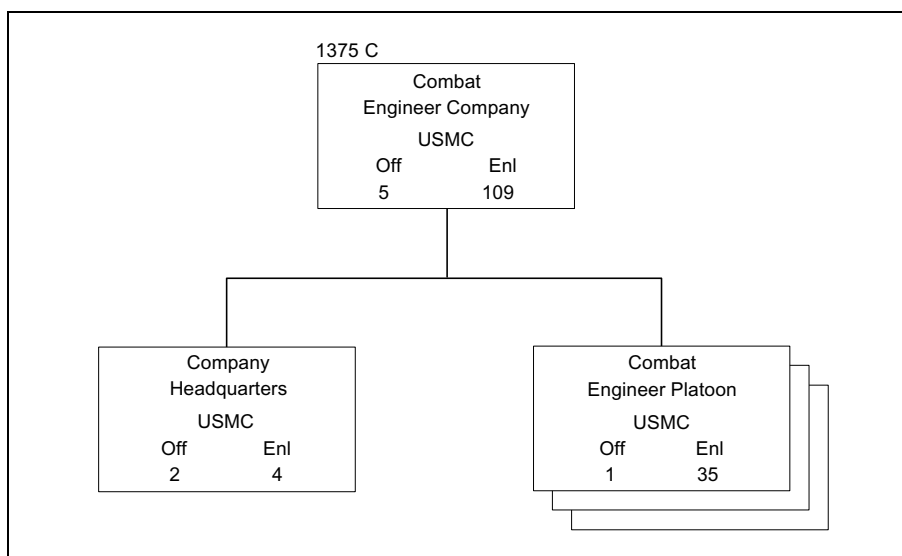

Figure 4-15. Combat Engineer Company, Combat Engineer Battalion.

TAM Number	Item	Quantity
B0055	Bath Shower Unit Expeditionary Field	36
B0286	SIXCONS (Water), 900-gal	40
B0395	Compressor, Air, 250 CFM, Trailer-Mounted w/Pneumatic	5
B0399	Crane, Rough Terrain, Hydraulic, 30-ton	4
B0589	Excavator, Combat, M9 Armored Combat Earthmover (ACE)	16
B0590	Excavator, Hydraulic, Multipurpose Wheel	1
B0635	Floodlight Set, Skid-Mounted, w/Tower	5
B0646	Forklift Attachment, 10,000-lb Capacity	8
B0953	Generator Set, 30 kW, 60 Hz, Skid-Mounted	40
B1021	Generator Set, 60 kW, 60 Hz, Skid-Mounted	18
B1045	Generator Set, 100 kW, 60 Hz, Skid-Mounted	10
B1082	Grader, Road, Motorized	6
B1326	Mixer, Concrete, Trailer-Mounted	1
B1785	Roller, Compactor, Vibratory	2
B1922	Scraper-Tractor, Wheeled	2
B2085	SIXCONS (Fuel)	2
B2086	Storage Tank Module, Water (SIXCONS)	40
B2130	Tank, Fabric, Collapsible, 3,000-gal	117
B2444	Tractor, Full-Track, Small, w/Bullgrader	5
B2460	Tractor, Full-Track, w/Angled Blade	18
B2462	Tractor, Medium, Full-Track	5
B2465	Tractor, Rubber Tired, Articulate Steering	10
B2467	Tractor, RT, Wheeled, Industrial	5
B2482	Tractor, All Wheel Drive, w/Attachments	15
B2560	Truck, Forklift	8
B2565	Truck, Forklift, Rough Terrain	5
B2600	Water Purification Set	12
B2604	Water Purification Unit-Reverse Osmosis	8
B2690	Welding Machine, Hard Surfacing	14
D0090	Cleaner, Steam Pressure Jet, Trailer-Mounted	2
D0190	Lubricating and Servicing Unit, Power Operated	2
D0209	Power Unit, Front, 12 1/2 -ton, 4 x 4	3
D0235	Trailer, Semi-, Lowbed, 40-ton	3
D0878	Trailer, Semi-, Powered, 5th Wheel, 4 x 4	3
D0880	Trailer, Water Tank, 400-gal	6
D1059	Truck, Cargo, 5-ton, 6 x 6, w/o Winch	10
D1072	Truck, Dump, 5-ton, 6 x 6, w/o Winch	24
D1110	Truck, Tank, Fuel Serv, 1,200-gal	2
D1134	Truck, Tractor	3
D1140	Truck, Tractor, 10-ton, 6 x 6, w/WN	3
D1212	Truck, Wrecker, 5-ton, 6 x 6	2

Table 4-7. Selected Items of Equipment for the Engineer Support Company, Combat Engineer Battalion.

(3) Communications. Communications support is provided by the H&S company of the combat engineer battalion.

(4) Mobility. The company possesses a limited amount of helicopter-transportable equipment. It requires heavy motor transport support to displace its various platoons and/or squads. When augmented with vehicles from the engineer support company, the combat engineer company can achieve mobility that is compatible with the support unit except in mechanized operations. In this case, it then becomes the responsibility of the support unit to allot sufficient space in its combat vehicles to provide comparable engineer mobility.

c. Concept of Employment

A combat engineer company is generally in direct support of an infantry regiment for operations. Although the company may operate under the centralized control of the company commander, it may more frequently operate under the control of the platoon leaders in widely dispersed areas, with the company commander acting as advisor to the infantry regimental commander. One combat engineer company is provided for support of division elements to the rear of forward areas and to augment the engineer companies in forward areas, as required. The combat engineer company has limited construction equipment, some of which is helicopter transportable. Equipment augmentation with operators is furnished as necessary from the engineer support company. In all such cases, control of augmenting elements is generally passed to the combat engineer company requiring such assistance.

d. Administrative Capability

Administrative support is provided at the battalion level.

e. Logistic Capabilities

(1) Maintenance

(a) Organic. The combat engineer company is capable of providing organizational (1st echelon) maintenance on all organic equipment. Organizational (2d echelon) maintenance on motor transport and engineer equipment is provided by the engineer support company of the combat engineer battalion. Intermediate (3d and 4th echelon) maintenance is provided by the maintenance battalion of the FSSG.

(b) Support. The combat engineer company receives no external maintenance support.

(2) Supply. Supply support is provided by the H&S company of the combat engineer battalion.

(3) Medical. Medical support is provided by the H&S company of the combat engineer battalion.

(4) Transportation. Transportation support is provided by the engineer support company of the combat engineer battalion.

(5) Messing. Food service support is provided by the H&S company of the combat engineer battalion.

(6) Selected Items of Equipment. For a list of selected items of equipment, see table 4-8.

4013. Light Armored Reconnaissance (LAR) Battalion

a. Mission

The mission of the LAR battalion is to conduct reconnaissance, security, and economy-of-force operations and, within capabilities, conduct limited offensive or delaying operations that exploit the unit's mobility and firepower.

TAM		
Number	Item	Quantity
A2051	Radio set, manpack (PLRS), AN/PSQ-4 1	3
B0471	Demolition equipment, engineer squad	9
B0475	Detecting set, mine, portable, metal, AN/PSS12	9
B1298	Line charge launch kit	9
B1830	Saw, chain, one-man portable	9
D1158	Truck, utility, 1 1/4 ton, M998	15

Table 4-8. Selected Items of Equipment for the Combat Engineer Company.

b. Concept of Organization

The LAR battalion consists of an H&S company and four LAR companies.

c. Concept of Employment

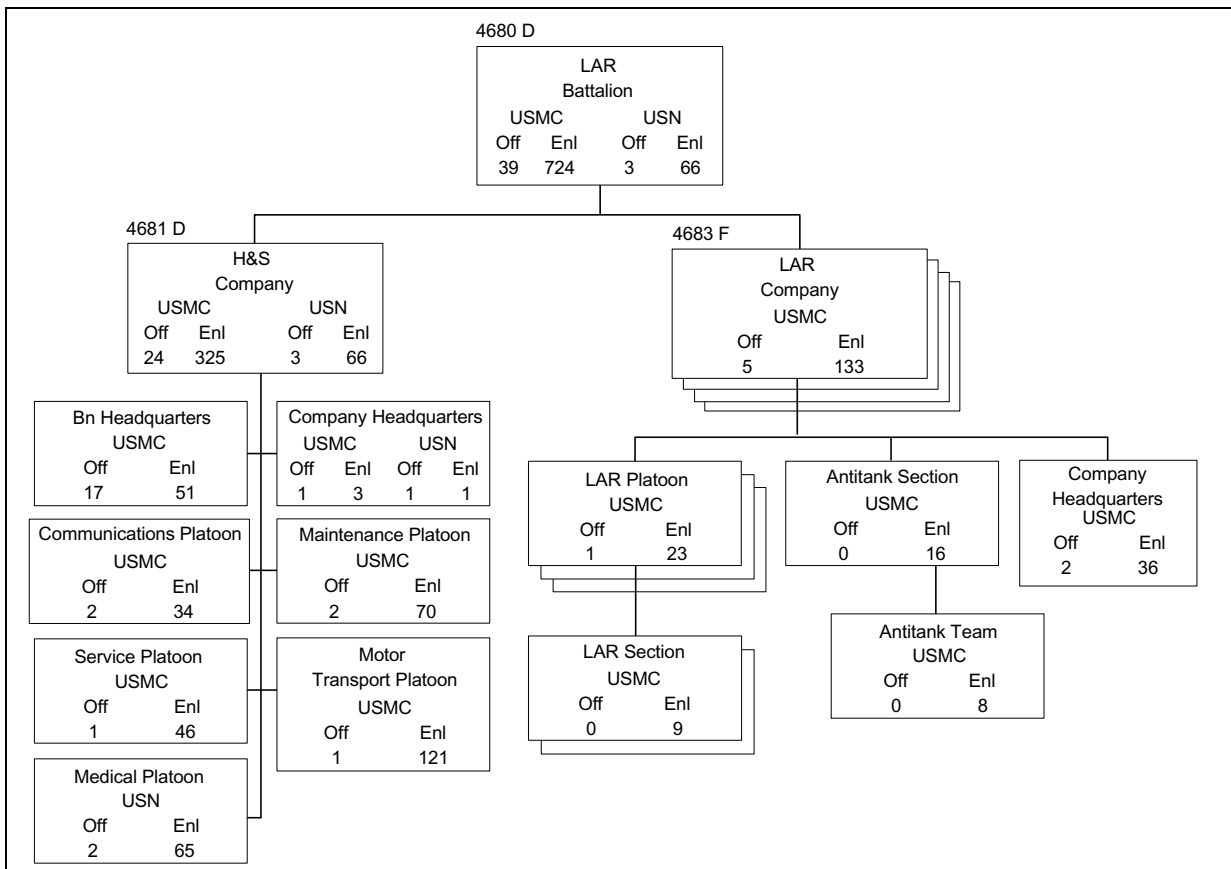

Figure 4-16. LAR Battalion.

The LAR battalion and its subordinate companies are capable of being employed separately or as part of a GCE. Speed and firepower, combined with maneuver, are used to exploit the offense in all types of combat operations. The LAR battalion assets emphasize the mobility and firepower that are characteristic of light armored vehicles (LAVs). See figure 4-16 for the basic tactical unit for employment of the LAR battalion in the reinforced LAR company.

d. Logistic Capabilities

(1) Administration. The LAR battalion is capable of self-administration.

(2) Maintenance. The LAR battalion is capable of organizational maintenance (1st and 2d echelon) on all equipment organic to the battalion and intermediate maintenance (3d echelon) on the LAV. The battalion also has limited intermediate (3d echelon) maintenance capability for organic communications equipment.

(3) Medical. The battalion medical platoon provides preventive medicine, treatment for minor illnesses and injuries, and emergency lifesaving for battle and other casualties. Injured and sick persons requiring hospitalization are readied and evacuated to the rear. Two battalion aid stations can be formed to permit mobile and flexible medical support.

(4) Transportation. Variants of the LAV provide tactical mobility for the battalion. When required, a light helicopter may be provided to the battalion commander for command and control, liaison, and observation purposes. Organic motor transport assets and motor transport assets from the MAGTF CSSE provide transportation for administrative and logistic functions.

(5) Supply. A combination of supply point and unit distribution methods of resupply is used to support the LAR battalion and its subordinate units. The battalion is capable of organic supply support.

TAM Number	Item	Quantity
A1957	Radio set, AN/MRC-145	3
A1935	Radio set, AN/MRC-138	3
B2567	Tractor, 644E	1
D0209	Logistics Vehicle System (LVS), MK48 FPU	3
D0080	Chassis, trailer, M353	7
D0090	Steam cleaner, JQM-1	4
D0190	Lubrication and service unit	2
D0860	Trailer, cargo, M105A2	10
D0880	Trailer, tank, water, 400 gal, M149A1	8
D1002	Ambulance, 1 1/4 ton, HMMWV	2
D1059	Truck, 5 ton, M923	20
D1158	HMMWV, 1 1/4 ton, M1008	23
D1212	Truck, wrecker, M936	2
E0942	LAV, antitank	16
E0946	LAV, command and control	10
E0947	LAV, light assault-25	60
E0948	LAV, logistic	16
E0949	LAV, mortar	8
E0950	LAV, maintenance/recovery	6

Table 4-9. Selected Items of Equipment for the LAR Battalion.

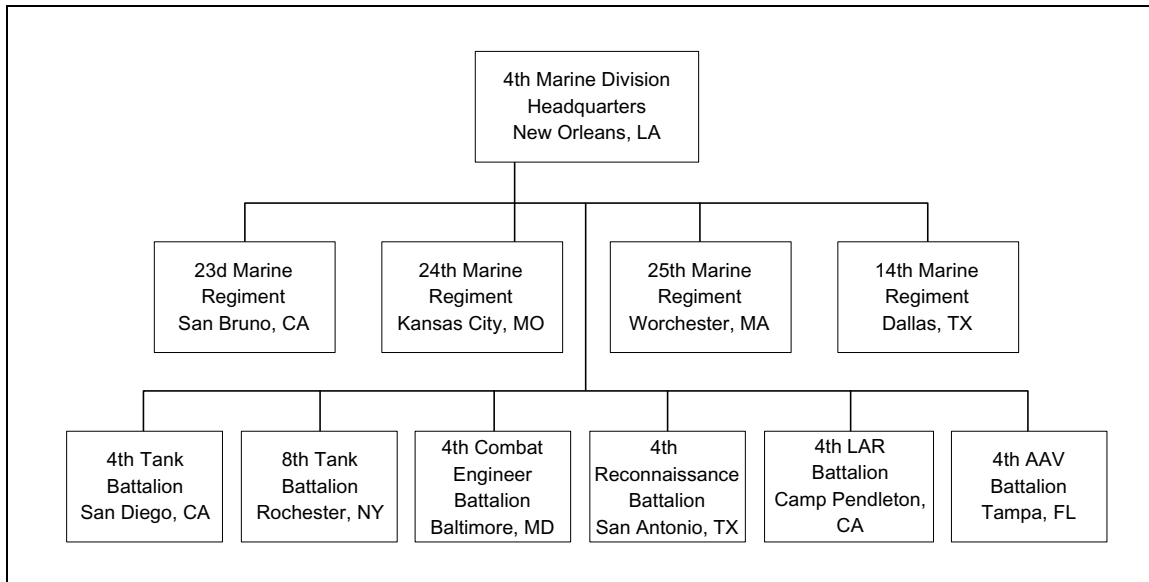

Figure 4-17. 4th Marine Division.

(6) Messing. The LAR battalion is capable of organic food service support.

(7) Selected Items of Equipment. For selected items of equipment, see table 4-9.

4014. Marine Corps Forces Reserve

a. Mission

The mission of the 4th Marine Division is to provide trained combat and combat support personnel and units to augment and reinforce the active component in time of war, in national emergencies, and at other times as national security requires and to have the capability to reconstitute the division, if required. (See figure 4-17.)

b. Mobilization

The MPLAN provides detailed guidance and procedures for mobilizing/recalling members of the Reserve.

Chapter 5

Marine Force Service Support Groups

5001. General

The FSSG is a composite grouping of functional components that provides CSS above the organic capability of supported units to all elements of the MEF. In this respect, it is structured to support, in garrison or deployed, a one-division/one-wing-configured MEF. All elements of the FSSG are structured to provide permanently organized subelements to support independently deployed battalions, regiments, MEUs (i.e., task-organized groups to provide support, as required and preplanned), or geographically separated units in garrison.

The most significant attribute of the FSSG is that it is a permanently organized command charged with the responsibility of providing all major CSS functions for the MEF beyond the organic capabilities of the supported units/organizations. Thus, it is staffed and equipped by T/Os and T/Es to support a one-division/one-wing MEF or four MEUs simultaneously.

The FSSG embodies a fundamental principle—economy of operations through centralization of CSS resources and decentralization in executing CSS tasks—in a conscious effort to attain efficient use of these scarce resources (personnel, supplies, and equipment) and a rational, aggressive assignment of work priorities. The FSSG commander, through his staff and by a coordinated, mutual exchange of operational information with supported MAGTF organizational/unit commanders, tailors each FSSG organization to meet specific preplanned requirements. Task-organized CSSEs, in support of deployed forces, provide the FSSG commander, his staff, and other CSS planners with operational and historical data on which to base future planning by means of narrative and statistical reports.

5002. Force Service Support Group Command Element

a. Mission

The FSSG CE provides general and direct support and sustained CSS above the organic capabilities of supported elements of MAGTFs in the functional areas of CSS during deployment and employment of the MEF and smaller, geographically separated MAGTFs in all levels of conflict.

b. Tasks

- w Provide centralized ground supply support, beyond supported units' organic capabilities, for the sustainment of the MEF, including procurement, storage, care in storage, distribution, salvage, disposal, and bulk fuel and water supply support.
- w Provide authorized overflow organizational (2d echelon) and intermediate (3d and 4th echelon) maintenance support, beyond supported units' organic capabilities, for Marine Corps-furnished ground equipment of the MEF, including inspection, classification, servicing, adjustment, tuning, testing, calibration, repair, modification, rebuilding overhaul, reclamation, recovery assistance, and evacuation.
- w Coordinate transportation and throughput support, beyond supported units' organic capabilities, for the deployment and employment of the MEF, including embarkation, landing support, port and terminal operations, motor transport, air delivery, and freight/passenger transportation support.
- w Provide general engineering support to the MEF, including engineering reconnaissance; horizontal construction of roads, CSS installations, and other support facilities; vertical construction and maintenance of encampment and other personnel support facilities; emplacement of standard and nonstandard bridging and rafting; demolition and obstacle

removal; augmentation for tasks beyond the organic engineering capabilities of supported units; and explosive ordnance disposal (EOD).

- w Provide health service (medical and dental) support, beyond the supported units' organic capabilities, to the MEF, including health maintenance, patient collection and treatment, temporary hospitalization, patient regulation and evacuation, disease control, hygienic services, and a comprehensive dental program.
- w Coordinate services support, beyond supported units' organic capabilities for the MEF, including security support, postal, disbursing, and exchange services; legal services (including active duty nucleus capability for CA); CSS-related CA support; and graves registration.

c. Concept of Organization

The FSSG is a permanently structured command that constitutes the CSSE of the MEF. When manned and equipped at full T/O and T/E levels, the FSSG can support

a MEF, or four MEUs simultaneously, or a combination of various smaller CSSEs, MEU service support groups (MSSGs), or CSSDs in support of MAGTF operations below MEF level. It is capable of providing the CE nucleus for three MSSGs/CSSEs to support MAGTFs. The FSSG includes an H&S battalion for command and control and seven permanently organized battalions that provide logistics and CSS along functional area lines. Similar functions are generally centralized at the battalion level to facilitate command and control, coordination of taskings and training, and maintenance of equipment. Within the limits of their capabilities, each battalion provides personnel and equipment to source task-organized CSSEs that are established to support MAGTFs. See figures 5-1a, 5-1b, 5-1c, and 5-1d.

(1) Command and Control. The FSSG commander exercises command and control of the FSSG through the general/special staff and subordinate commanders by using organic communications assets. This system permits the FSSG commander to structure organizations, assign appropriate missions and tasks, and establish appropriate command relationships that enhance efforts to achieve centralized control while facilitating decentralized execution of CSS tasks. When required, the FSSG commander task organizes CSSEs from the assets of the functional battalions.

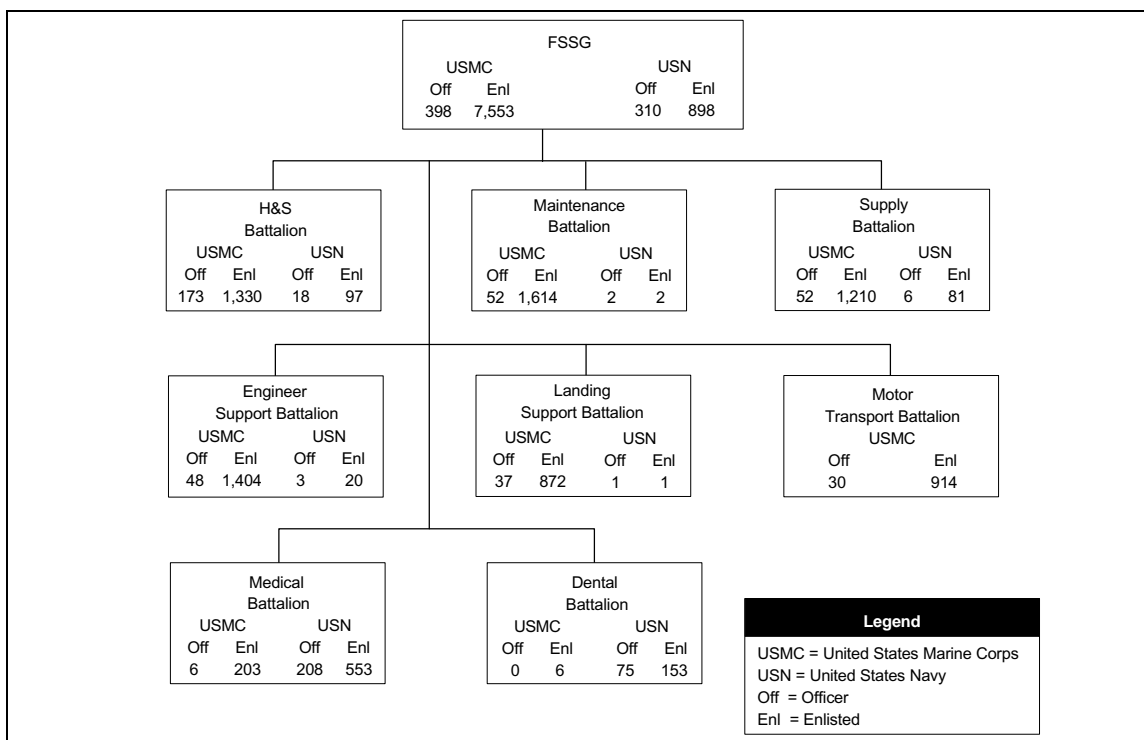

Figure 5-1a. FSSG Organization.

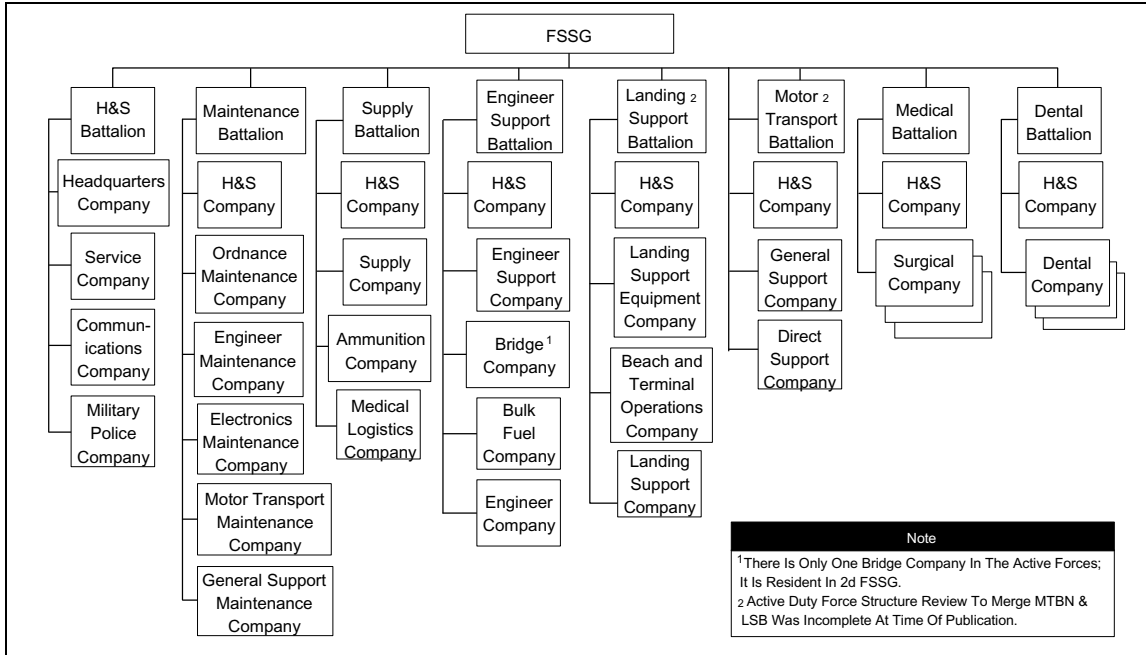

Figure 5-1b. 1st and 2d FSSG Organization.

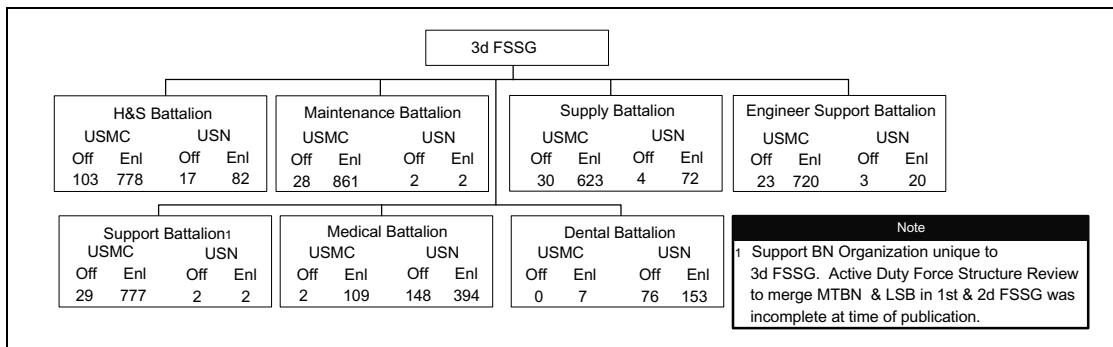

Figure 5-1c. 3d FSSG Organization.

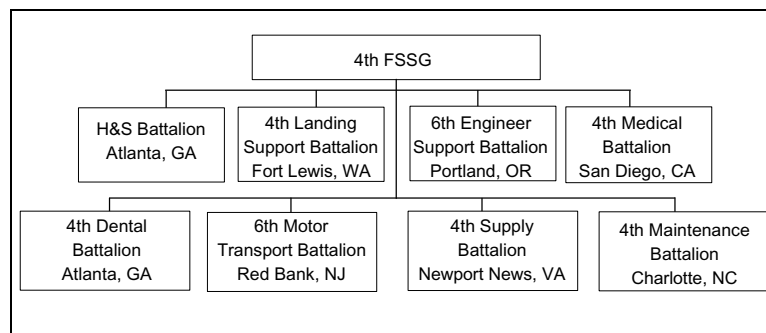

Figure 5-1d. 4th FSSG Organization.

The mission and composition of supported MAGTFs dictate the type, size, and composition of the supporting CSSEs.

(2) Firepower. Organic firepower capability is limited to individual and crew-served weapons. The FSSG must rely on other MEF elements for artillery, NGF, and aviation fire support, including fire support coordination capabilities.

(3) Mobility. Organic medium- and heavy-lift vehicles can displace the FSSG in echelons. Use of organic transportation to move the FSSG degrades its ability to provide simultaneous transportation support to the MEF.

(4) Communications. The FSSG possesses sufficient organic communications capabilities to install, operate, and maintain communications systems for internal and limited external communications requirements.

(5) Intelligence. The organic intelligence gathering and processing capabilities of the FSSG are limited. They include limited tactical and logistical intelligence support for the FSSG CE and organic battalions.

(6) Security. The FSSG is responsible for the local security of established CSS installations against ground attack and employs passive defense measures against other forms of attack. When tasked by the MEF commander, it also coordinates security within the MEF rear area. Antiair and antimechanized rear area security requirements must be satisfied by other elements of the MEF. Within its capability, the FSSG provides security for lines of communications in the MEF rear area used by the FSSG in transporting supplies, equipment, and personnel. It coordinates security requirements with supported units for such movements within the supported units' areas of responsibility.

d. Concept of Employment

The FSSG provides sustained CSS to each element of the MEF in the functional areas of CSS beyond the organic capabilities of supported units. It provides CSSEs to smaller MAGTFs that may be permanently organized or task organized for specific missions. When supporting a task-organized force that is greater than the combined assets of one division and one aircraft wing, the FSSG may require augmentation for requirements beyond its organic capabilities. To provide the necessary throughput support to the MEF, the FSSG establishes, as required, beach support areas, landing zone support areas, CSS areas (CSSAs), a

force CSSA (FCSSA), and other CSS installations commensurate with the level of operations to ensure responsive, timely support for the sustainment of the MEF.

e. Administrative Capability

Each organic battalion and CSSD CE nucleus is capable of self-administration.

f. Logistic Capabilities

(1) Supply. The FSSG is capable of organic supply support. It provides selected consumer-level and full intermediate-level ground supply support, including class I subsistence supply support to the MEF and other FMF units, as required.

(2) Maintenance. The FSSG is capable of organizational and intermediate-level (1st through 4th echelon) maintenance on organic equipment. It provides general support intermediate maintenance (3d and 4th echelons) on Marine Corps-furnished ground equipment to other units of the MEF for those units not authorized those levels of maintenance and, when performance of authorized maintenance exceeds supported units' capability, overflow organizational (2d echelon) maintenance.

(3) Transportation. The FSSG is capable of organic transportation support. It provides medium- and heavy-lift motor transport support and coordinates the movements of elements of the MEF to, from, and through ports of embarkation and debarkation.

(4) General Engineering. The FSSG is capable of general support engineering support to organic FSSG and supported MEF units that require EOD support and intensive engineering efforts involving detailed planning and preparation to meet standards, design, and construction criteria beyond the organic capabilities of supported units.

(5) Health Services. The FSSG is capable of providing medical and dental support to organic battalions and other units of the MEF when those units' needs exceed their organic capabilities.

(6) Services. The FSSG is capable of services support to organic FSSG units and supported MEF units in the functional areas of security support, disbursing, postal, and exchange services; logistic information systems; legal services support; CA support; and graves registration.

(7) Messing. The FSSG is capable of organic food service support.

5003. Headquarters and Service Battalion

a. Mission

The H&S battalion provides command and control, administration, services, communications, and security support to the FSSG and coordination of services support beyond supported-unit organic capabilities to MAGTFs.

b. Tasks

- w Provide necessary command support functions for the FSSG, including food service support to FSSG organizations (except for engineering support, landing support, and medical bat- lions).
- w Provide administrative support, including maintenance of personnel records for Navy personnel assigned to the MEF.
- w Coordinate services support provided to MAGTFs, beyond organic capabilities of supported units, in the functional areas of disbursing, postal, and exchange services; legal services; and graves registration.
- w Provide communications support for the CEs of the FSSG, subordinate FSSG organizations, and CSSEs of MAGTFs.
- w Provide security support to the FSSG and the MEF, including battlespace circulation control, area security, EPW management, and support for the maintenance of law and order.
- w Provide the nucleus staff for the coordination of marshalling and deployment support for the MEF, with necessary augmentation from supported units as required.

c. Concept of Organization

The battalion is organized to provide command, control, and command support functions for the FSSG and its H&S battalion and to provide appropriate support in CSS functional areas for the deployment/employ- ment of the MEF or the simultaneous deployment/em- ployment of two brigade service support groups (BSSGs) and the remaining FSSG elements. (See figure 5-2 on page 5-6.)

(1) Command and Control. The battalion commander exercises command and control through the battalion staff and subordinate company commanders. He directs and controls command support functions relating to operations, administration, and logistics/CSS for the battalion. The command structure and centralization of services support functions in the H&S battalion permit the battalion commander to coordinate services support tasks assigned to the battalion and to plan and structure appropriate CSSEs for MAGTF deployments.

(2) Firepower. Organic firepower capability is limited to individual and crew-served weapons for personal and local security.

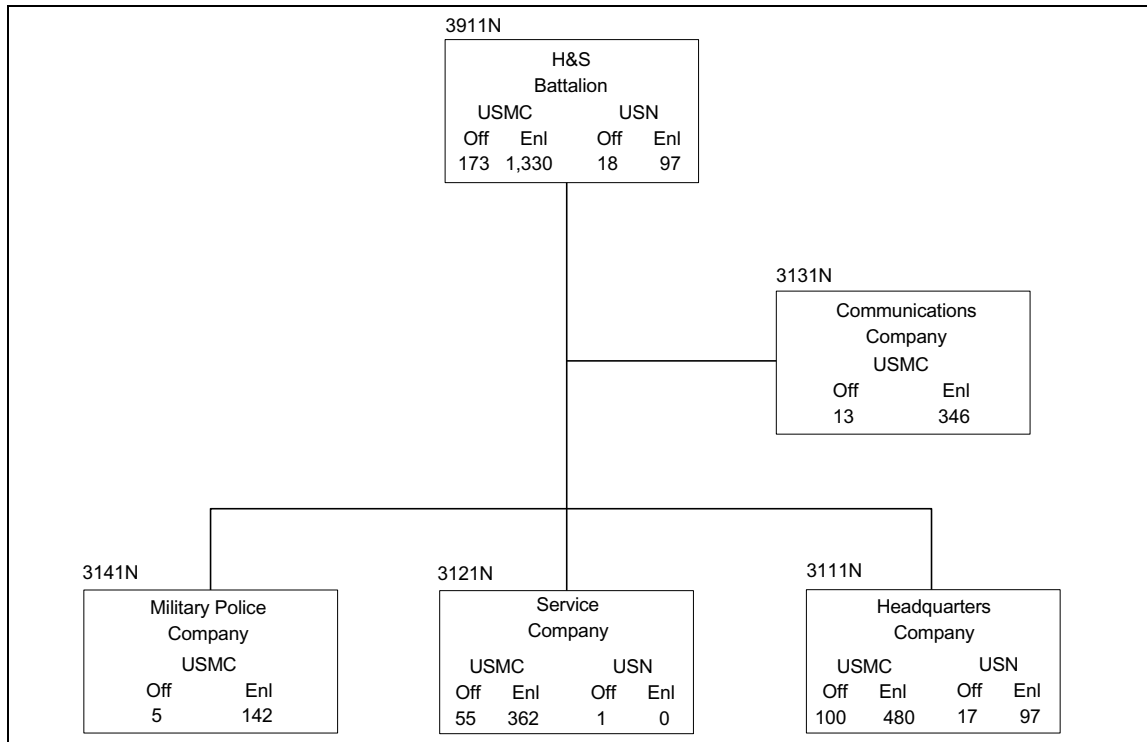

Figure 5-2. H&S Battalion.

(3) Mobility. Organizational vehicles of the battalion provide limited mobility. Transportation support from the motor transport battalion of the FSSG is required to effect displacement.

(4) Communications. The battalion is capable of organic communications support for the requirements of subordinate units and those of the CEs of the FSSG and subordinate CSSEs.

(5) Intelligence. The H&S battalion has no organic intelligence capability. Intelligence support is provided by the FSSG headquarters.

(6) Security. The H&S battalion is responsible for the local security of CSS installations established within its area of responsibility against ground attack and employs passive defense measures against other forms of attack. Antiair and antimechanized rear area security requirements must be satisfied by other elements of the MAGTF. Within its capability, the H&S battalion provides security for lines of communications in the MAGTF rear area used by the FSSG in transporting supplies, equipment, and personnel. It coordinates security requirements with supported units for such movements within the supported units' areas of responsibility.

d. Concept of Employment

The H&S battalion provides, under a single services-oriented commander, the command and control organization to achieve an integration of capabilities that are essential to the services support requirements of the MEF and the FSSG. Subordinate units of the battalion, under the centralized control of the battalion commander, are capable of responsive, adaptable task organization to meet the particular support requirements to establish and sustain the relative combat power of the MEF and/or MAGTFs smaller than a MEF.

e. Administrative Capability

The battalion is capable of self-administration.

f. Logistic Capabilities

(1) Supply. The battalion is capable of organic supply support for the battalion and maintenance float supply support for the communications company's critical low-density communications-electronics equipment.

(2) Maintenance. The battalion is capable of organizational (1st and 2d echelon) maintenance on organic equipment, except for motor transport equipment.

(a) The headquarters company of the H&S battalion provides organizational (2d echelon) maintenance support for organic motor transport equipment.

(b) The communications company provides organizational (1st echelon) maintenance support for organic equipment and organizational (2d echelon) maintenance support for engineering and communications-electronics equipment that is organic to the communications company.

(c) The maintenance battalion provides intermediate (3d and 4th echelon) maintenance support for critical low-density communications-electronics equipment and for other organic equipment.

(3) Transportation. The battalion is capable of organic transportation support for command and administrative purposes.

(4) General Engineering. Engineering support, as required, is provided by the engineer support battalion of the FSSG.

(5) Health Services. Health Services is organic to and provides primary care for the H&S battalion and those battalions of the FSSG that do not possess an organic medical support capability. The dental battalion provides the necessary dental support.

(6) Services. The battalion is capable of coordinating those service support functions provided to the FSSG and supported MEF units in the functional areas of security support, disbursing, postal, and exchange services; logistic information systems; legal services; CA support; and graves registration.

(7) Messing. The battalion is capable of operating a single consolidated mess to provide food service support for the H&S, maintenance, supply, and motor transport battalions. It can operate up to three separate mess halls in support of task-organized elements of the FSSG.

5004. Headquarters Company, Headquarters and Service Battalion

a. Mission

The headquarters company provides command and control, administration, and command support functions for the H&S battalion, the FSSG, and the CSSE nucleus CEs. (See table 5-1 on page 5-8.)

b. Tasks

- w Provide command, control, and coordination of H&S battalion and FSSG operations in support of MEF operations.
- w Provide command support functions, including consolidated administration, organic supply, food service, and motor transport support for the battalion.
- w Provide food service support for the maintenance, supply, and motor transport battalions of the FSSG.

c. Concept of Organization

The company is organized to plan, coordinate, and supervise the command support functions for the FSSG in support of MEF operations and for the CEs of CSSEs that are task organized for operations of MAGTFs smaller than a MEF. (See figure 5-3 on page 5-9.)

(1) Command and Control. The company commander directs and controls command support functions relating to operations, administration, and logistics/CSS for the company.

(2) Firepower. Organic firepower capability is limited to individual and crew-served weapons for personal and local security.

(3) Mobility. Organizational vehicles of the company provide limited mobility. Transportation support is required from the motor transport battalion to effect displacement.

(4) Communications. Communications support, as required, is provided by the communications company of the H&S battalion.

d. Concept of Employment

The company is structured to facilitate task organization for operations conducted by the battalion in support of MAGTF operations.

e. Administrative Capability

	Marine Officer	Marine Enlisted	Navy Officer	Navy Enlisted
Group command section	2	2	0	1
Chief of staff section	2	2	0	0
Tactical readiness and training section	1	3	0	0
G-1 section	9	34	0	3
G-2 section	5	19	0	0
G-3 section	22	115	3	4
G-4 section	6	19	1	2
G-6 section	6	8	0	0
CSSE CE (Nucleus) (3)	21	23	0	0
Comptroller section	3	7	0	0
Staff Judge Advocate section	2	2	0	0
Chaplain section	0	0	2	3
Group medical section	0	0	10	84
Battalion headquarters	2	2	0	0
S-1 adjutant section	2	31	0	0
Chaplain section	0	0	1	0
S-3 section	1	5	0	0
S-4 section	3	13	0	0
Battalion supply section	1	15	0	0
Motor transport platoon	1	26	0	0
Food service platoon	0	122	0	0
Company headquarters	<u>1</u>	<u>3</u>	<u>0</u>	<u>0</u>
Total	90	452	16	91

Table 5-1. Personnel of the Headquarters Company, H&S Battalion.

The company is capable of self-administration and contains the consolidated administration section for the H&S battalion.

f. Logistic Capabilities

(1) Supply. The company is capable of organic supply support.

(2) Maintenance. The company is capable of organizational (1st and 2d echelon) maintenance on organic equipment. Intermediate (3d and 4th echelon) maintenance support is provided by the maintenance battalion.

(3) Transportation. The company is capable of organic transportation support for command and administrative purposes.

(4) General Engineering. Engineering support, as required, is provided by the engineer support battalion.

(5) Health Services. Medical support is provided by H&S battalion, and dental support is provided by the dental battalion.

(6) Services. Services support, as required, is provided by the service company of the H&S battalion.

(7) Messing. The company is capable of organic food service support and provides food service support to the H&S, maintenance, supply, and motor transport battalions.

(8) Selected Items of Equipment. See table 5-2.

5005. Service Company, Headquarters and Service Battalion

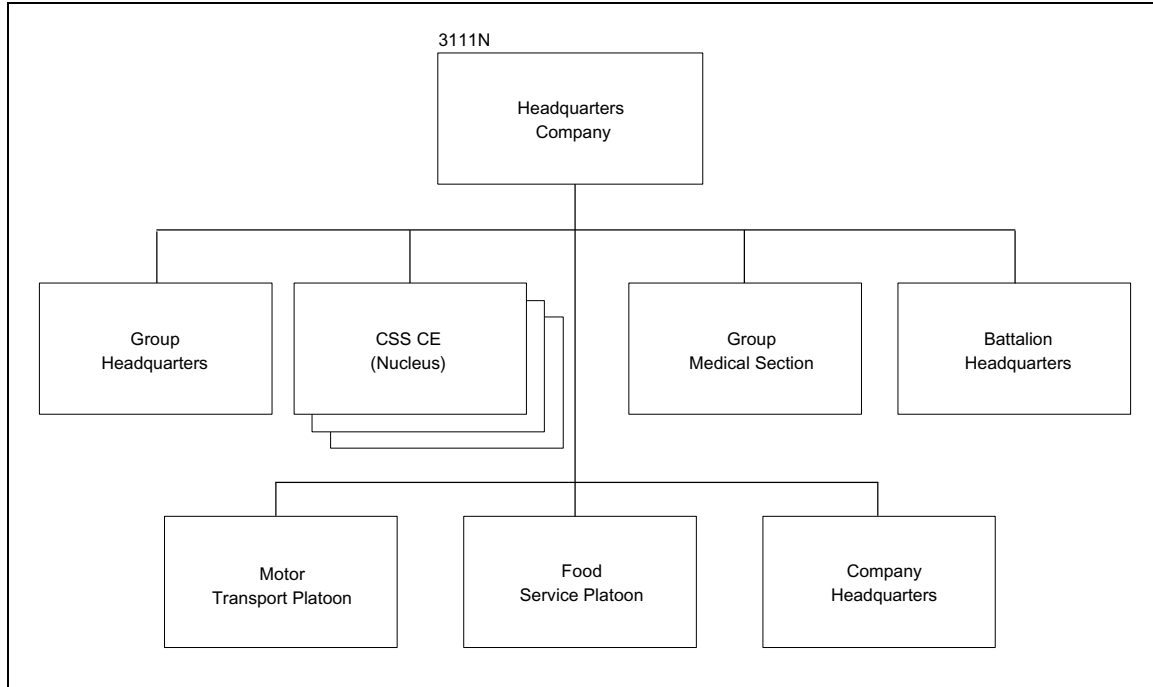

Figure 5-3. Headquarters Company, H&S Battalion.

a. Mission

The service company provides general support services support for the MEF and administrative and disbursing support for U.S. Navy personnel assigned to the MEF.

- w Provide general support services support to the MEF in the areas of disbursing, postal, and exchange services; logistic information systems; and legal services.
- w Provide the nucleus for initial active duty CA support for the MEF.

b. Tasks

TAM Number	Item	Quantity
A2030	Radio set, AN/PRC-68A	6
B1291	Decon sys, ltwt, M1731	6
D0201	Motorcycle, military, M1030	2
D0850	Trailer, cargo, 3/4 ton, M101	21
D0860	Trailer, cargo, 1 1/2 ton, M105	10
D0880	Trailer, tank, water, 400 gal, M149	12
D1001	Truck, ambulance, M997	3
D1002	Truck, ambulance, M1035	1
D1059	Truck, cargo, 5 ton, M923	26
D1158	Truck, utility, 1 1/4 ton, M998	75
D1212	Truck, wrecker, 5 ton, M936	1
E0980	Machine gun, .50 cal, M2	10
E0989	Machine gun, 7.62 mm, M240G	2
F0994	Machine gun, 40 mm, MK19	13

Table 5-2. Selected Items of Equipment for the Headquarters Company of the H&S Battalion.

w Provide administrative support, including maintenance of personnel records, for Navy personnel assigned to the MEF.

c. Concept of Organization

The company is organized in functionally oriented, general support platoons that are structured to provide subsections in each of the functional capabilities for support of the MEF.

(1) Command and Control. The company commander directs and controls command support functions relating to operations, administration, and logistics/CSS for the company.

(2) Firepower. Organic firepower capability is limited to individual and crew-served weapons for personal and local security.

(3) Mobility. Transportation support, as required, is provided by the headquarters company of the H&S battalion and the motor transport battalion to effect displacement.

(4) Communications. Communications support, as required, is provided by the communications company of the H&S battalion.

d. Concept of Employment

The company provides general support services support to the MEF and/or task organizes detachments for MAGTFs smaller than a MEF to support specific services support requirements. (See figure 5-4.)

e. Administrative Capability

The MEF Navy personnel support section of the service company provides administrative and disbursing support for U.S. Navy personnel assigned to the MEF. Administrative support for assigned Marine Corps personnel is provided by the consolidated administration section of the headquarters company of the H&S bat- talion.

f. Logistic Capabilities

(1) Supply. Supply support is provided by the headquar- ters company of the H&S battalion.

(2) Maintenance. The company is capable of organiza- tional (1st and 2d echelon) maintenance on organic equipment.

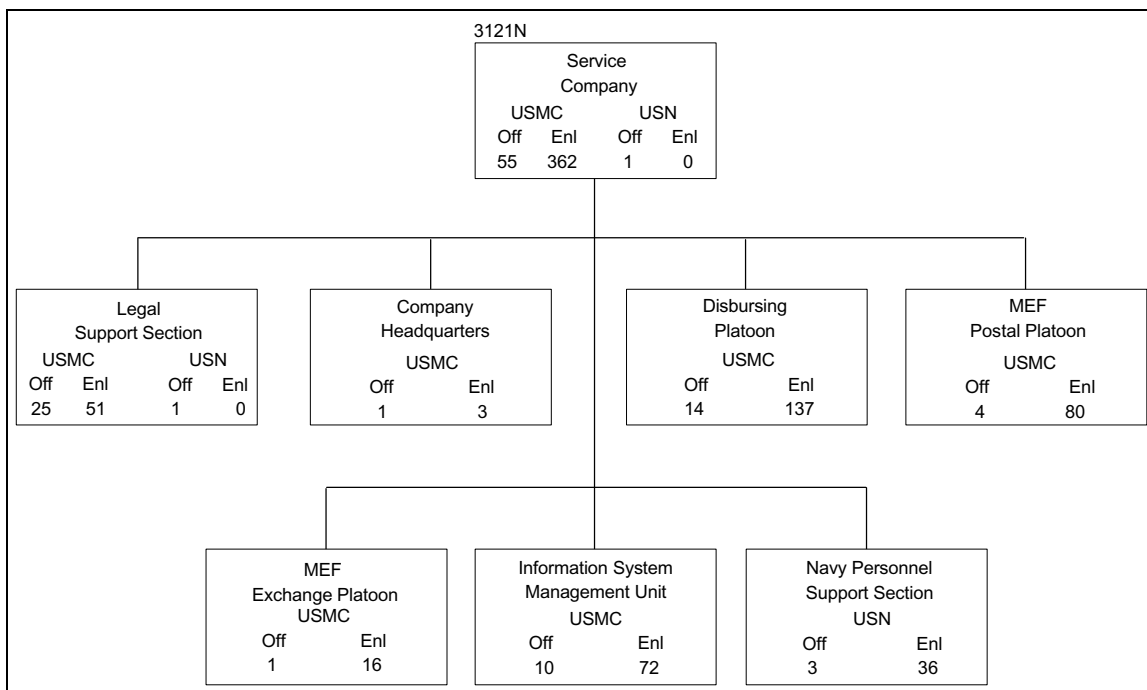

Figure 5-4. Service Company, H&S Battalion.

(3) Transportation. Transportation support, as required, is provided by the motor transport battalion or by supported units.

(4) General Engineering. Engineering support, as required, is provided by the engineer support battalion.

(5) Health Services. Medical support is provided by the headquarters company of the H&S battalion, and dental support is provided by the dental battalion.

(6) Services. The company is capable of services support for organic FSSG and supported MEF units in the functional areas of disbursing, postal, and exchange services; logistic information systems; legal services support; CA support; and graves registration.

(7) Messing. Food service support is provided by the headquarters company of the H&S battalion.

(8) Selected Items of Equipment. See table 5-3.

5006. Communications Company, Headquarters and Service Battalion

a. Mission

The communications company provides communications support to the CEs of the FSSG and subordinate CSSEs without organic communications capabilities in support of MAGTF operations.

b. Tasks

- w Provide communications support for the FSSG headquarters/FCSSA.
- w Provide communications support to the CEs of three MSSGs. Install, operate, and maintain communications control facilities within the FSSG communications system.
- w Install, operate, and maintain tactical automatic switching and wire communications for the FCSSA/FSSG headquarters and three CSSAs and, when required, provide small-scale switching within maintenance, supply, medical, and dental battalions, and the bulk fuel company of the engineer support battalion.

c. Concept of Organization

The company is structured to provide communications support to the FSSG headquarters in MEF operations and task-organized detachments to the CEs of CSSEs that are deployed with MAGTFs smaller than a MEF. (See figure 5-5 on page 5-12.)

(1) Command and Control. The company commander directs and controls command support functions relating to operations, administration, and logistics/CSS for the company.

(2) Firepower. Organic firepower capability is limited to individual and crew-served weapons for personal and local security.

(3) Mobility. Organizational vehicles of the company provide limited mobility. Transportation support is required to effect displacement.

TAM Number	Item	Quantity
B0005	Air conditioner, MCS vertical, 60 H2 36K Btu	5
E0989	Machine gun, M240G	2
E0994	Machine gun, 40 mm, MK19	4

Table 5-3. Selected Items of Equipment for the Service Company of the H&S Battalion.

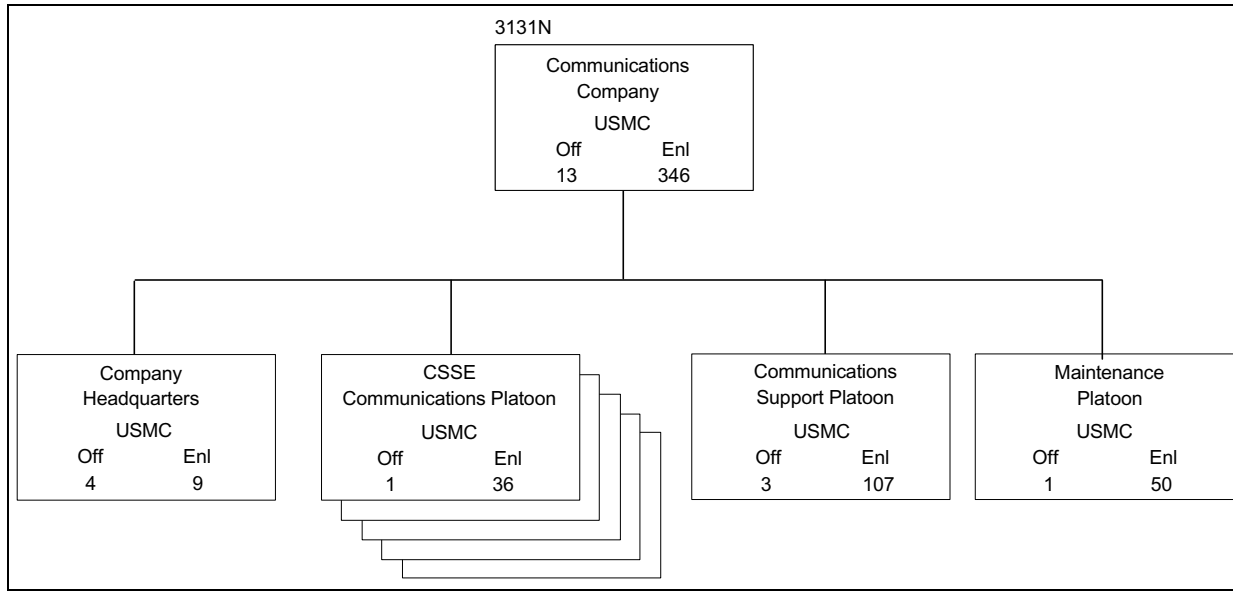

Figure 5-5. Communications Company, H&S Battalion.

(4) Communications. The company is capable of organic communications support. Augmentation from the MEF communications battalion is required if a dedicated naval telecommunications system/defense communications system entry is required.

d. Concept of Employment

The company is the primary source of communications support for the FSSG headquarters and other CSSE CEs.

e. Administrative Capability

Administrative support is provided by the consolidated administrative section of the headquarters company of the H&S battalion.

f. Logistic Capabilities

(1) Supply. Supply support is provided by the headquarters company of the H&S battalion.

(2) Maintenance. The company is capable of organizational (1st echelon) maintenance on organic equipment; organizational (2d echelon) maintenance on organic engineering, motor transport, and communications-electronics equipment, except for test equipment; and intermediate (3d echelon) maintenance on ground communications-electronics critical low-density equipment that is organic to the H&S battalion.

(3) Transportation. The company is capable of organic transportation support for command and administrative purposes.

(4) General Engineering. Engineering support, as required, is provided by the engineer support battalion.

(5) Health Services. Medical support is provided by the H&S battalion, and dental support is provided by the dental battalion.

(6) Services. Services support, as required, is provided by the service company of the H&S battalion.

(7) Messing. Food service support is provided by the headquarters company of the H&S battalion.

(8) Selected Items of Equipment. See table 5-4.

5007. Military Police Company, Headquarters and Service Battalion

a. Mission

The MP company provides security support, including battlespace circulation control, area security, EPW control, and law-and-order operations to the FSSG and the MEF and to MAGTFs smaller than a MEF.

b. Tasks

- w Provide foot and motor patrols to perform battlespace circulation control and reconnaissance along main supply routes and lines of communications to—
 - { Ensure the uninterrupted movement of troops and supplies
 - { Assist in the control of refugees and strag- glers
 - { Reconnoiter new routes, road trafficability, and signs of enemy activity
 - { Prevent infiltration and surprise attacks
 - { Enforce main supply route regulations and provide traffic control and traffic enforce- ment.
- w Perform intelligence gathering functions and disseminate the intelligence obtained through appropriate channels.
- w Coordinate security activities with the rear area operations center to assist in the rear area security effort and with MAGTF and/or non-MAGTF CA units, as appropriate, to assist in efforts to protect the local populace and its resources.
- w Operate a temporary detention facility for U.S. military prisoners awaiting trail or evacuation.
- w Operate a MAGTF EPW holding facility that provides for the processing, temporary internment, and transfer of EPWs to U.S. Army or host nation facilities.

TAM		
Number	Item	Quantity
A2048	Central office, telephone, AN/TTC-42(V)	3
A0311	Control central, AN/TSQ84	1
A1816	Radio set, AN/GRC-210	1
A1957	Radio set, AN/MRC-145	14
A1935	Radio set, AN/MRC-138	10
A1955	Radio terminal set, AN/MRC-142	16
A2070	Radio set, AN/PRC-119A	65
A2065	Radio set, AN/PRC-104	21
A2151	Radio set, AN/VSQ-1	3
A2167	Radio set, AN/VRC-88A	15
A2168	Radio set, AN/VRC-89A	3
A2480	Switchboard, telephone, manual, SB-22/PT	10
A2505	Switchboard, telephone, automatic, SB-3614(V)TT	6
A2635	Telephone set, TA-838-/TT	120
B0730	Generator set, 3 kW, 60 Hz, MEP-016A	10
D0850	Trailer, cargo, 3/4 ton, two wheel, M101A1	2
D0860	Trailer, cargo, 1 1/2 ton, two wheel, M105A2	2
D0880	Trailer, tank, water, 400 gal, M149A1	1
D1059	Truck, cargo, 5 ton, M923	3
D1158	Truck, utility, 1 1/4 ton, M998	9
D0201	Motorcycle, military, M1030	4
E0980	Machine gun, .50 cal, M2	4
E0989	Machine gun, 7.62 mm, M240G	2
F0994	Machine gun, 40 mm, MK19	3

Table 5-4. Selected Items of Equipment for the Communications Company.

- w Perform law-and-order functions, including law enforcement, criminal investigations, accident investigations, and crime prevention/physical security services.
- w Perform offensive and defensive operations, within capabilities, against minor enemy units operating in the rear area and as a reaction force in support of friendly units engaged with the enemy.

c. Concept of Organization

The company is structured to provide task-organized security support detachments to deployed MAGTFs. (See figure 5-6.)

(1) Command and Control. The company commander directs and controls command support functions relating to operations, administration, and logistics/CSS for the company.

(2) Firepower. Organic firepower capability is limited to individual and crew-served weapons for personal and local security.

(3) Mobility. The company is primarily footmobile. Organizational vehicles of the company provide limited mobility. Transportation support is required to effect displacement.

(4) Communications. The MP company possesses sufficient communications assets to support itself.

d. Concept of Employment

The company can support simultaneously deployed CSSEs of MAGTFs smaller than a MEF. It provides a mobile security force to patrol main supply routes/lines of communications within the MAGTF's area of responsibility and areas surrounding main supply routes/lines of communications, assists the CSSE commander in area security, manages EPW operations, and performs law-and-order tasks to assist in the maintenance of good order and discipline throughout the MAGTF's area of responsibility.

e. Administrative Capability

Administrative support is provided by the consolidated administrative section of the headquarters company of the H&S battalion.

f. Logistic Capabilities

(1) Supply. Supply support, as required, is provided by the headquarters company of the H&S battalion.

(2) Maintenance. The company is capable of organizational (1st and 2d echelon) maintenance on organic equipment. Intermediate (3d and 4th echelon) maintenance support is provided by the maintenance bat- talion.

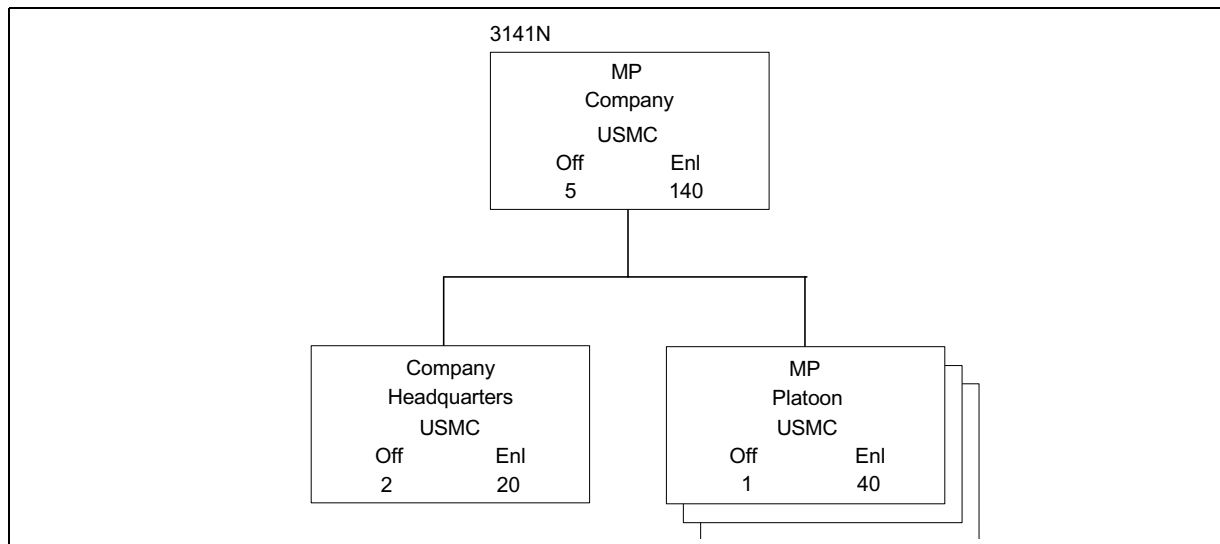

Figure 5-6. MP Company, H&S Battalion.

(3) Transportation. The company is capable of organic transportation support for command and administrative purposes.

(4) General Engineering. Engineering support, as required, is provided by the engineer support battalion.

(5) Health Services. Medical support is provided by the H&S battalion, and dental support is provided by the dental battalion.

(6) Services. Services support, as required, is provided by the service company of the H&S battalion.

(7) Messing. Food service support is provided by the headquarters company of the H&S battalion or by the supported unit.

(8) Selected Items of Equipment. See table 5-5.

5008. Maintenance Battalion

a. Mission

The maintenance battalion provides general support and intermediate (3d and 4th echelon) maintenance support for Marine Corps-furnished tactical ordnance, engineering, motor transport, communications electronics, and general support equipment of the MEF.

b. Tasks

- w Provide 3d echelon maintenance on end items by means of component/subassembly replacement or repair.
- w Provide intermediate (4th echelon) maintenance in support of the secondary repairable program, including repairing and rebuilding components and subassemblies of end items.
- w Provide a tracked-vehicle evacuation capability.
- w Provide calibration services for electronic and mechanical TMDE.
- w Provide organizational (2d echelon) and intermediate (3d and 4th echelon) maintenance on end items.
- w Provide technical assistance and overflow organizational (2d echelon) maintenance for supported units as directed by higher headquarters.
- w Provide intermediate maintenance and modification applications on in-stock equipment.
- w Provide technical inspection services, as required, in support of equipment maintenance programs of the MEF.

c. Concept of Organization

The battalion is structured to provide command and control for centralized coordination and decentralized execution of maintenance efforts to sustain the combat power of the MEF. Subordinate companies are organized along functional area lines to provide maintenance support in

TAM Number	Item	Quantity
A1957	Radio set, AN/MRC-145	14
A2070	Radio set, AN/PRC-119	17
A2167	Radio set, AN/VRC-88A	24
D0201	Motorcycle, military, M1030	2
D1158	Truck, utility, 5 ton, M998	7
E0980	Machine gun, .50 cal, M2	9
E0989	Machine gun, 7.62 mm, M240G	9
E0994	Machine gun, 40 mm, MK19	4

Table 5-5. Selected Items of Equipment for the MP Company.

commodity areas that are critical to the warfighting capability of the MEF. (See figure 5-7.)

(1) Command and Control. The battalion commander exercises command and control of the battalion through the battalion staff and the company commanders. He directs and controls command support functions relating to operations, administration, and logistics/CSS for the battalion.

(2) Firepower. Organic firepower capability is limited to individual and crew-served weapons for personal and local security.

(3) Mobility. Organizational vehicles of the battalion provide limited mobility. Heavy motor transport support from the motor transport battalion is required to effect displacement.

(4) Communications. Communications support is provided by the communications company of the H&S battalion.

(5) Intelligence. Intelligence support, as required, is provided by the H&S battalion.

(6) Security. Security support, as required, is provided by the H&S battalion.

d. Concept of Employment

The battalion establishes and operates direct and general support intermediate maintenance facilities in support of the MEF or any combination of smaller MAGTFs. When not deployed as a battalion, the structure supports MAGTF operations through detachments composed of platoons from each of the functional companies; these platoons are task organized to provide the full range and depth of intermediate (3d and 4th echelon) maintenance. The detachments are assigned to the supporting CSSE. Depending on the tactical situation, decentralized execution of maintenance support is provided through task-oriented maintenance support teams that can provide on-site repair support. When maintenance needs exceed the capability of the maintenance support teams, unserviceable components normally are evacuated to the rear for rebuilding at an established CSSA or repair facility. The battalion (-) provides

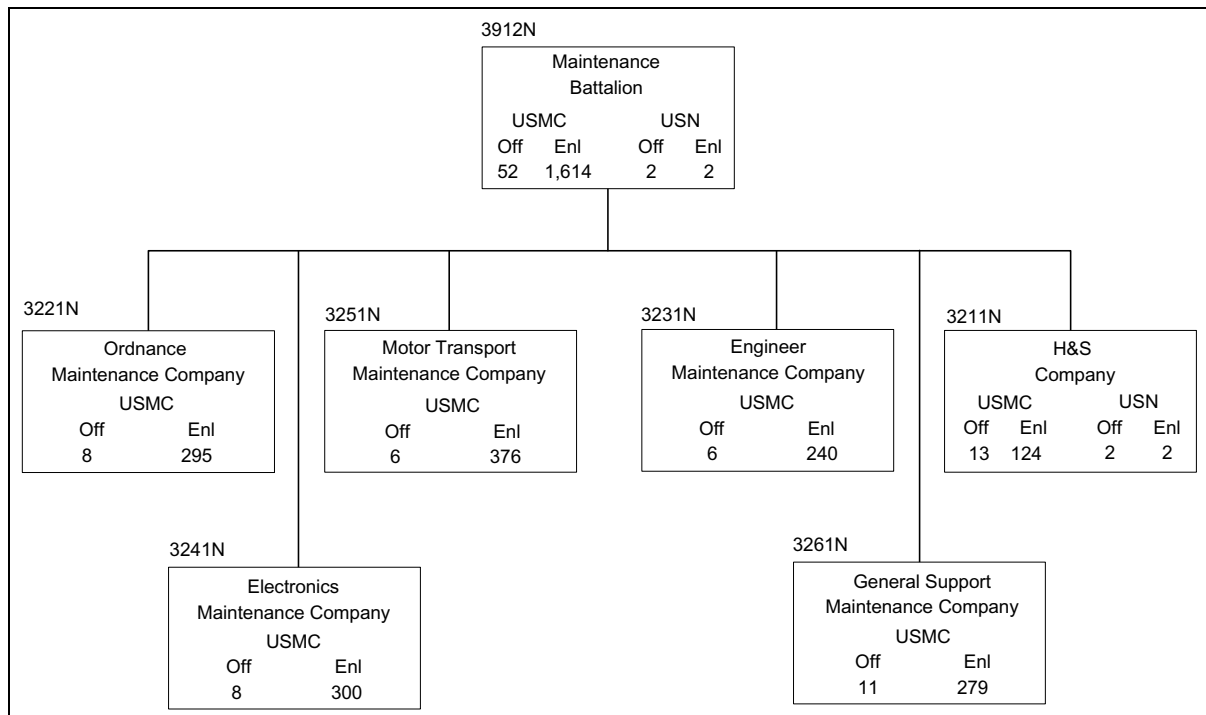

Figure 5-7. Maintenance Battalion.

intermediate (3d and 4th echelon) maintenance for residual MEF units, within its remaining organic capability.

e. Administrative Capability

The battalion is capable of self-administration.

f. Logistic Capabilities

(1) Supply. The battalion is capable of organic supply support.

(2) Maintenance. The battalion is capable of organizational (1st and 2d echelon) maintenance on organic equipment and intermediate (3d and 4th echelon) maintenance support for Marine Corps-furnished equipment of the MEF, except for those items that are subject to support/maintenance through inter-Service or other contract agreements.

(3) Transportation. The battalion is capable of organic transportation support for command and administrative purposes.

(4) General Engineering. Engineering support, as required, is provided by the engineer support battalion.

(5) Health Services. Medical support is provided by H&S battalion, and dental support is provided by the dental battalion.

(6) Services. Services support is provided by the service company of the H&S battalion.

(7) Messing. Food service support is provided by the H&S battalion.

5009. Headquarters and Service Company, Maintenance Battalion

a. Mission

The H&S company provides command and control, administration, and command support functions for the maintenance battalion.

b. Tasks

- w Provide command, control, and coordination of maintenance battalion operations in support of MEF operations.
- w Provide organizational (1st and 2d echelon) maintenance, within capabilities, on organic equipment.
- w Provide consolidated administrative and necessary logistics/CSS for the battalion.

c. Concept of Organization

The company is organized to plan, coordinate, and supervise the logistic/CSS functions of the subordinate elements of the battalion with assistance from the battalion supply and motor transport sections. It is structured to facilitate task organization for maintenance operations in support of the MEF or any combination of smaller MAGTFs. (See figure 5-8 on page 5-18.)

(1) Command and Control. The company commander directs and controls command support functions relating to operations, administration, and logistics/CSS for the company.

(2) Firepower. Organic firepower capability is limited to individual and crew-served weapons for personal and local security.

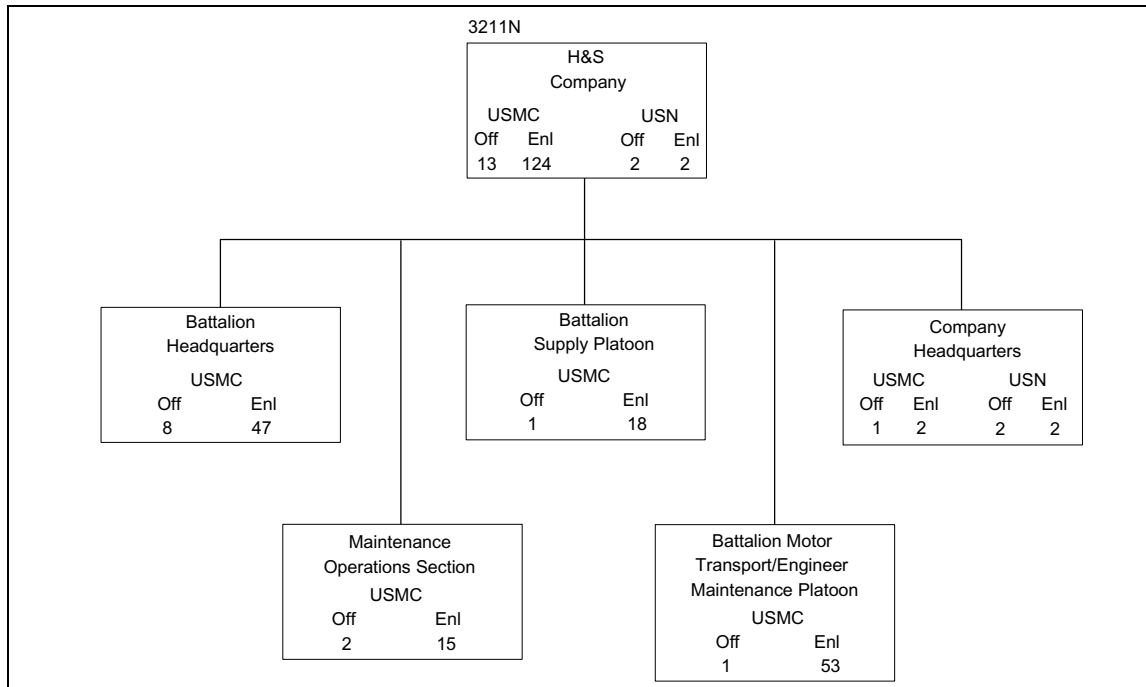

Figure 5-8. H&S Company, Maintenance Battalion.

(4) Mobility. Organizational vehicles of the company provide limited mobility. Heavy motor transport support from the motor transport battalion is required to effect displacement.

(5) Communications. Communications support, as required, is provided by the communications company of the H&S battalion.

d. Concept of Employment

The company deploys under the centralized control of the maintenance battalion and operates from a CSSA to provide command and administrative facilities for the battalion. Under decentralized control, detachments deploy to provide the same functions in two geographically separated areas.

e. Administrative Capability

The company is capable of self-administration and contains the consolidated administration section for the maintenance battalion.

f. Logistic Capabilities

(1) Supply. The company is capable of organic supply support.

(2) Maintenance. The company is capable of organizational (1st echelon) maintenance on organic equipment and organizational (2d echelon) maintenance on maintenance battalion ordnance and motor transport assets, except for general support maintenance on company vehicles. Maintenance support (2d through 4th echelons) for other organic equipment is provided by the appropriate companies of the maintenance battalion.

(3) Transportation. The company is capable of organic transportation support for command and administrative purposes.

(4) General Engineering. Engineering support, as required, is provided by the engineer support battalion.

(5) Health Services. Medical support is provided by H&S battalion, and dental support is provided by the dental battalion.

(6) Services. Services support, as required, is provided by the service company of the H&S battalion.

(7) Messing. Food service support is provided by the H&S battalion.

(8) Selected Items of Equipment. See table 5-6.

TAM Number	Item	Quantity
B1291	Decontaminating sys, ltwt, M1731	12
B0630	Floodlight set, skid-mtd	2
B0891	Generator set, 10 kW, 60 Hz, skid mounted, MEP-803A	26
B0953	Generator set, 30 kW, 60 Hz, skid mounted, MEP-805A	17
B1021	Generator set, 60 kW, 60 Hz, skid mounted, MEP-806A	15
B1045	Generator set, 100 kW, 60 Hz, skid mounted, MEP-007B	7
B1620	Pump set, 65 gal/min, 50-ft head	2
D0080	Chassis, trailer, general purpose, 3 1/2 ton, M-353	32
D0860	Trailer, cargo, 1 1/2 ton, two wheel, M105A2	8
D0880	Trailer, tank, water, 400 gal, M149A1	4
D1059	Truck, cargo, 5 ton, M923	10
D1061	Truck, cargo, 5 ton, extra-large wide bed (XLWB), with winch, M928	4
D1158	Truck, utility, 1 1/4 ton, M998	9
D1212	Truck, wrecker, M936	2

Table 5-6. Selected Items of Equipment for the H&S Company of the Maintenance Battalion.

5010. Ordnance Maintenance Company, Maintenance Battalion

a. Mission

The ordnance maintenance company provides intermediate (3d and 4th echelon) maintenance support for Marine Corps-furnished ordnance equipment of a MEF.

b. Tasks

- w Provide task-oriented maintenance support teams to effect on-site repairs of ordnance equipment as feasible, including tracked-vehicle evacuation.
- w Provide end-item maintenance at established repair facilities when maintenance requirements exceed the capability of maintenance support teams to effect repairs.
- w Provide technical assistance and overflow organizational maintenance for supported units as directed by higher headquarters.
- w Provide required maintenance on stored ordnance equipment before issue.

w Provide technical inspection services in support of the MEF commanders' equipment maintenance programs.

w Provide heavy recovery for a MEF or MAGTF.

c. Concept of Organization

The company is structured to provide the appropriate technical and supervisory personnel and equipment, plus ordnance maintenance support, for a MEF or MAGTFs smaller than a MEF. It is organized to facilitate the task organization of ordnance maintenance assets for support of a MEF or up to four MEUs deployed in widely separated geographical areas. (See figure 5-9 on page 5-20.)

(1) Command and Control. The company commander directs and controls command support functions relating to operations, administration, and logistics/CSS for the company.

(2) Firepower. Organic firepower capabilities are limited to individual and crew-served weapons for personal and local security.

(3) Mobility. Organizational vehicles of the company provide limited mobility. Transportation support is required to effect displacement.

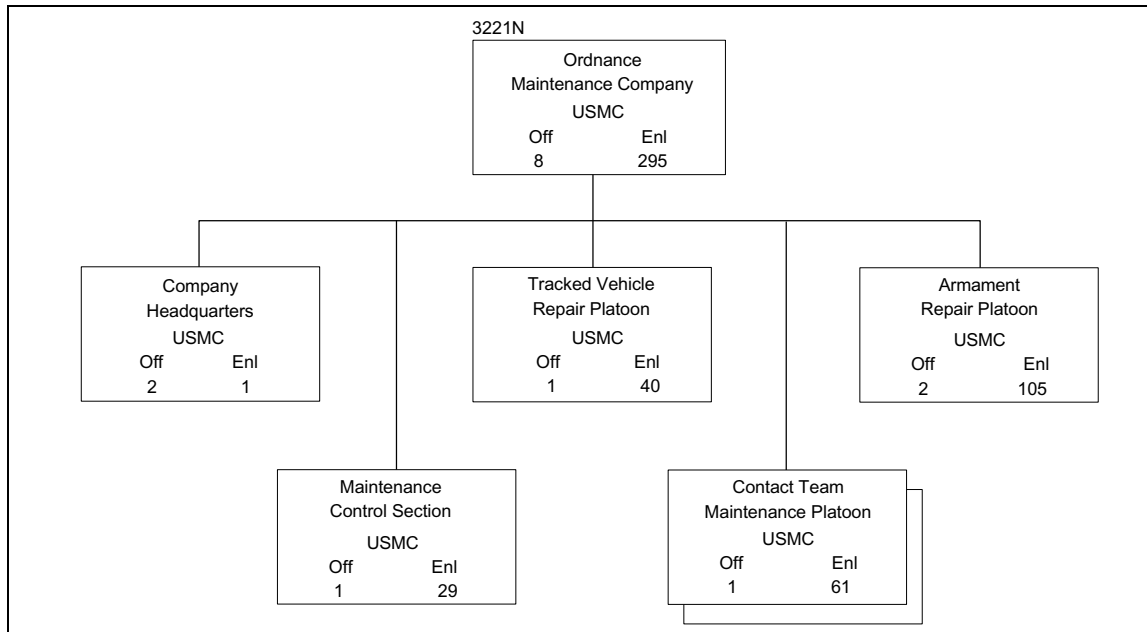

Figure 5-9. Ordnance Maintenance Company, Maintenance Battalion.

(4) Communications. Communications support, as required, is provided by the communications company of the H&S battalion.

d. Concept of Employment

When operating as a unit under centralized control in the FCSSA or under decentralized control from two CSSAs, the company operates intermediate maintenance facilities for the repair of ground ordnance equipment. The primary method of employment is decentralized execution of maintenance support provided through task-oriented maintenance support teams to effect on-site repairs that exceed the organic maintenance capabilities of supported units. When repairs cannot be accomplished on site, disabled/unserviceable equipment is evacuated to company repair facilities.

e. Administrative Capability

Administrative support is provided by the consolidated administrative section of the H&S company of the maintenance battalion.

f. Logistic Capabilities

(1) Supply. Supply support is provided by the H&S company of the maintenance battalion.

(2) Maintenance. The company is capable of organizational (1st echelon) maintenance on organic equipment; organizational (2d echelon) maintenance on organic ordnance equipment, except for motor transport equipment; and intermediate (3d and 4th echelon) maintenance on Marine Corps-furnished ground ordnance equipment of the MEF. For other organic equipment, appropriate companies of the maintenance battalion provide organizational (2d echelon) and intermediate (3d and 4th echelon) maintenance support.

(3) Transportation. The company is capable of organic transportation support for command and administrative purposes.

(4) General Engineering. Engineering support, as required, is provided by the engineer support battalion.

(5) Health Services. Medical support is provided by H&S battalion, and dental support is provided by the dental battalion.

(6) Services. Services support, as required, is provided by the service company of the H&S battalion.

(7) Messing. Food service support is provided by the headquarters company of the H&S battalion.

(8) Selected Items of Equipment. See table 5-7.

5011. Engineer Maintenance Company, Maintenance Battalion

a. Mission

The engineer maintenance company provides intermediate (3d and 4th echelon) maintenance support for Marine Corps-furnished engineering equipment of a MEF.

b. Tasks

- w Provide task-oriented maintenance support teams to effect on-site repairs of engineering equipment as feasible, including the Marine Corps-furnished engineering equipment of an MPF.
- w Provide end-item maintenance at established repair facilities when maintenance requirements exceed the capabilities of maintenance support teams to effect repairs.

- w Provide technical assistance and overflow organizational maintenance for supported units as directed by higher headquarters.
- w Provide required maintenance on stored engineering equipment before issue.
- w Provide technical inspection services in support of the MEF commanders' equipment maintenance programs.

c. Concept of Organization

The company is structured to provide the appropriate technical and supervisory personnel and equipment to provide engineering maintenance support for a MEF or MAGTFs smaller than a MEF. It is organized to facilitate the task organization of engineering maintenance assets for support of a MEF or up to four MEUs deployed in widely separated geographical areas. (See figure 5-10 on page 5-22.)

(1) Command and Control. The company commander directs and controls command support functions relating to operations, administration, and logistics/CSS for the company.

(2) Firepower. Organic firepower capability is limited to individual and crew-served weapons for personal and local security.

TAM Number	Item	Quantity
B1620	Pump set, 65 gal/min, 50-ft head	2
B2130	Tank, fabric, collapsible, 3,000 gal	2
B2685	Welding machine, arc, trailer mounted	2
D0190	Lubricating and servicing unit, power	1
D1158	Truck, utility, 1 1/4 ton, M998	9
D1212	Truck, wrecker, M936	2
E0856	Assault amphibious vehicle (AAV) recovery, AAVR7A1 4	
E1377	Recovery vehicle, full tracked, medium, M88A1	4
E1713	Shop set, electro-optics	4
E1712	Shop set, maint, artillery	4
E1715	Shop set, ordnance contact, M1010	4
D1714	Shop set, small arms	4

Table 5-7. Selected Items of Equipment for the Ordnance Maintenance Company of the Maintenance Battalion.

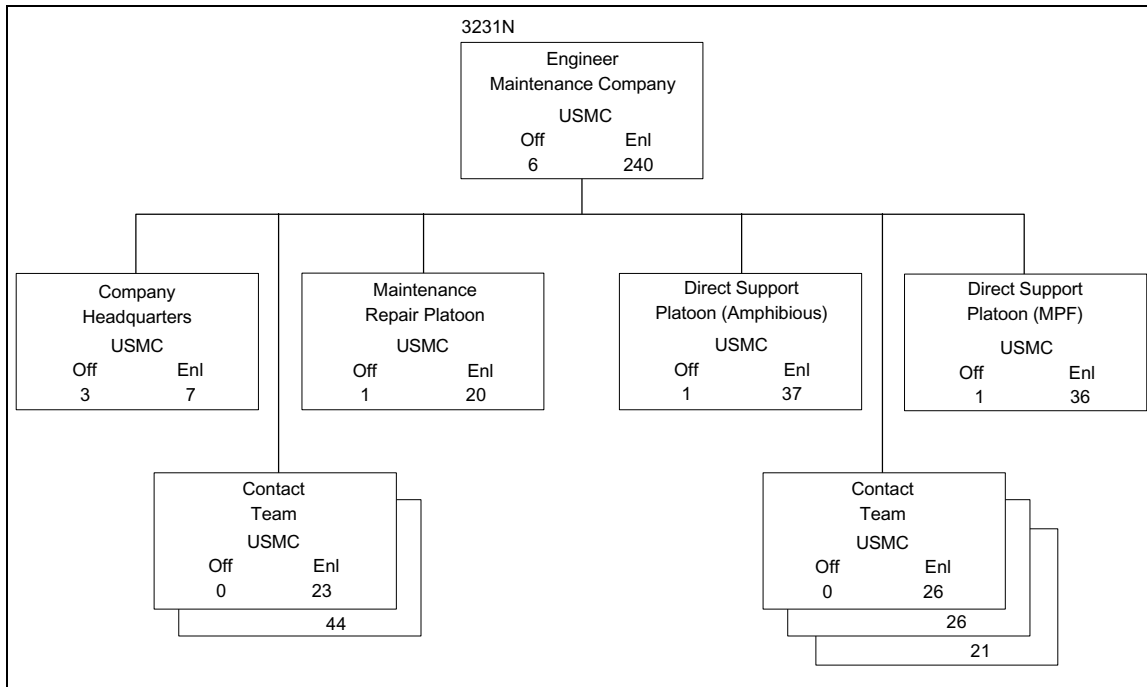

Figure 5-10. Engineer Maintenance Company, Maintenance Battalion.

(3) Mobility. Organizational vehicles of the company provide limited mobility. Transportation support is required from the motor transport battalion or the supported unit to effect displacement.

(4) Communications. Communications support, as required, is provided by the communications company of the H&S battalion.

d. Concept of Employment

When operating as a unit under centralized control in the FCSSA or under decentralized control from two CSSAs, the company operates intermediate maintenance facilities for the repair of engineering equipment. The primary method of employment is decentralized execution of maintenance support provided through task-oriented maintenance support teams to effect on-site repairs that exceed the organic maintenance capabilities of supported units. When repair cannot be accomplished on site, disabled/unserviceable equipment is evacuated to company repair facilities.

e. Administrative Capability

Administrative support is provided by the consolidated administrative section of the H&S company of the maintenance battalion.

f. Logistic Capabilities

(1) Supply. Supply support is provided by the H&S company of the maintenance battalion.

(2) Maintenance. The company is capable of organizational (1st echelon) maintenance on organic equipment and organizational (2d echelon) and intermediate (3d and 4th echelon) maintenance on fabric and engineering equipment of the MEF, except for motor transport equipment. For other organic equipment, appropriate companies of the maintenance battalion provide organizational (2d echelon) and intermediate (3d and 4th echelon) maintenance support.

(3) Transportation. The company is capable of organic transportation support for command and administrative purposes and of heavy transportation support to effect the evacuation of engineering equipment.

(4) General Engineering. Engineering support, as required, is provided by the engineer support battalion.

(5) Health Services. Medical support is provided by H&S battalion, and dental support is provided by the dental battalion.

(6) Services. Services support, as required, is provided by the service company of the H&S battalion.

(7) Messing. Food service support is provided by the headquarters company of the H&S battalion.

(8) Selected Items of Equipment. See table 5-8.

5012. Electronics Maintenance Company, Maintenance Battalion

a. Mission

The electronics maintenance company provides intermediate maintenance (3d and 4th echelon) support for the Marine Corps-furnished ground communications-electronics equipment of a MEF.

b. Tasks

- w Provide a repair capability for ground-common communications-electronics equipment of the MEF.
- w Provide task-oriented maintenance support teams to effect on-site repairs of ground communications-electronics equipment as feasible.
- w Provide end-item maintenance at established repair facilities when maintenance requirements exceed the capabilities of maintenance support teams to effect repairs.
- w Provide technical assistance and overflow organizational maintenance for supported units as directed by higher headquarters.
- w Provide technical inspection services in support of the MEF commanders' equipment maintenance programs.
- w Provide calibration services for Marine Corps-furnished TMDE that is organic to the MEF.

TAM Number	Item	Quantity
B0395	Compressor, 250 CFM	1
B0443	Crane, high speed	1
B0446	Crane, RT light	1
B1620	Pump set, 65 gal/min, 50-ft head	1
B1945	Shop equipment, contact maintenance	4
B1951	Shop equipment, general purpose, repair	1
B2060	Spray outfit, paint, 91-4500	3
B2130	Tank, fabric, collapsible, 3,000 gal	1
B2462	Tractor, medium, full tracked, D7G	1
B2567	Tractor, RT, articulated steer	1
B2566	Truck, fork lift, rough terrain, 4000 lbs	2
B2685	Welding machine, arc, trailer mounted	2
B2705	Winch attachment, single drum, FTRCT, G-80-SG	1
D0190	Lubricating and servicing unit, power	1
D0880	Trailer, tank, water, 400 gal, M149A1	1
D1158	Truck, utility, 1 1/4 ton, M998	7
D1212	Truck, wrecker, 5 ton, M936	2

Table 5-8. Selected Items of Equipment for the Engineer Maintenance Company.

- w Provide technical assistance on stored communications-electronics equipment before issue.
- w Provide computer repair support within capabilities.

c. Concept of Organization

The company is structured to provide the appropriate technical and supervisory personnel and equipment to provide communications-electronics maintenance support for a MEF or MAGTFs smaller than a MEF. It is organized to facilitate the task organization of communications-electronics maintenance assets for support of a MEF or up to four MEUs deployed in widely separated geographical areas. (See figure 5-11.)

(1) Command and Control. The company commander directs and controls command support functions relating to operations, administration, and logistics/CSS for the company.

(2) Firepower. Organic firepower capability is limited to individual and crew-served weapons for personal and local security.

(3) Mobility. Organizational vehicles of the company provide limited mobility. Transportation support is required to effect displacement.

(4) Communications. Communications support, as required, is provided by the communications company of the H&S battalion.

d. Concept of Employment

When operating as a unit under centralized control in the FCSSA or under decentralized control from two CSSAs, the company operates intermediate maintenance facilities for the repair of ground communications-electronics equipment. The primary method of employment is decentralized execution of maintenance support provided through task-oriented maintenance support teams to effect on-site repairs that exceed the organic maintenance capabilities of supported units. When repair cannot be accomplished on site, disabled/unserviceable equipment is evacuated to company repair facilities.

e. Administrative Capability

Administrative support is provided by the consolidated administrative section of the H&S company of the maintenance battalion.

f. Logistic Capabilities

(1) Supply. Supply support is provided by the H&S company of the maintenance battalion.

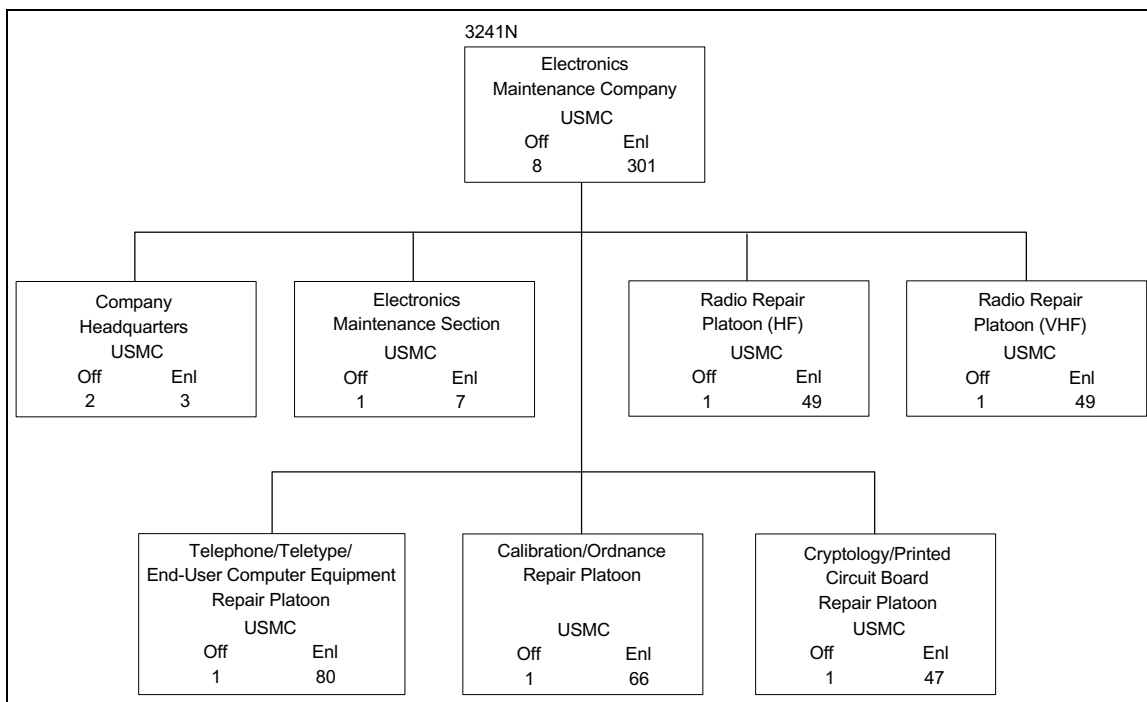

Figure 5-11. Electronics Maintenance Company, Maintenance Battalion.

(2) Maintenance. The company is capable of organizational (1st echelon) maintenance on organic equipment, organizational (2d echelon) maintenance on ground communications-electronics equipment, and intermediate (3d and 4th echelon) maintenance on Marine Corps-furnished ground-common communications-electronics equipment of the MEF. For other organic equipment, appropriate companies of the maintenance battalion provide organizational (2d echelon) and intermediate (3d and 4th echelon) maintenance support.

(3) Transportation. The company is capable of organic transportation support for command and administrative purposes and to effect evacuation of ground communications-electronics equipment to repair facilities.

(4) General Engineering. Engineering support, as required, is provided by the engineer support battalion.

(5) Health Services. Medical support is provided by H&S battalion, and dental support is provided by the dental battalion.

(6) Services. Services support, as required, is provided by the service company of the H&S battalion.

(7) Messing. Food service support is provided by headquarters company of the H&S battalion.

(8) Selected Items of Equipment. See table 5-9.

5013. Motor Transport Maintenance Company, Maintenance Battalion

a. Mission

The mission of the motor transport maintenance company is to provide intermediate (3d and 4th echelon) maintenance support for the motor transport equipment of the MEF.

b. Tasks

- w Provide task-oriented maintenance support teams to effect on-site repairs of motor transport equipment, as feasible.
- w Provide end-item maintenance at established repair facilities when maintenance requirements exceed the capabilities of maintenance support teams to effect repairs.
- w Provide technical assistance and overflow organizational maintenance for supported units as directed by higher headquarters.
- w Provide required maintenance on stored motor transport equipment before issue.

TAM Number	Item	Quantity
A1253	Power supply set, PP-7333	8
A1415	Radar set (LBSR), AN/PPS-15(V)	4
A1816	Radio set, AN/GRC-210	1
A2167	Radio set, AN/VRC-88A	5
A2335	Shelter, 10 ft, EMI	10
A2336	Shelter, 20 ft, EMI	20
A2480	Switchboard, telephone, SB-22/PT	2
A2505	Switchboard, telephone, SB-3614(V) TT	1
A2740	Test set, field cable, AN/GTM-3	2
A2835	Test set, electronic TS-4118/G	4
D1059	Truck, cargo, 5 ton, M928	8
D1061	Truck, 5 ton, XLWB, with winch, M998	3
D1158	Truck, utility, 1 1/4 ton, M923	5

Table 5-9. Selected Items of Equipment for the Electronics Maintenance Company.

w Provide technical inspection services in support of the MEF commanders' equipment maintenance programs.

c. Concept of Organization

The company is structured to provide the appropriate technical and supervisory personnel and equipment to provide motor transport maintenance support for a MEF or MAGTFs smaller than a MEF. It is organized to facilitate the task organization of motor transport maintenance assets for support of a MEF or up to four MEUs deployed in widely separated geographical areas. (See figure 5-12.)

(1) Command and Control. The company commander directs and controls command support functions relating to operations, administration, and logistics/CSS for the company.

(2) Firepower. Organic firepower capability is limited to individual and crew-served weapons for personal and local security.

(3) Mobility. Organizational vehicles of the company provide limited mobility. Heavy motor transport support is required to effect displacement.

(4) Communications. Communications support, as required, is provided by the communications company of the H&S battalion.

d. Concept of Employment

When operating as a unit under centralized control in the FCSSA or under decentralized control from two CSSAs, the company operates intermediate maintenance facilities for the repair of motor transport equipment. The primary method of employment is decentralized execution of maintenance support provided through task-oriented maintenance support teams to effect on-site repairs that exceed the organic maintenance capabilities of supported units. When repair cannot be accomplished on site, disabled or unserviceable equipment is evacuated to company repair facilities.

e. Administrative Capability

Administrative support is provided by the consolidated administrative section of the H&S company of the maintenance battalion.

f. Logistic Capabilities

(1) Supply. Supply support is provided by the H&S company of the maintenance battalion.

(2) Maintenance. The motor transport maintenance company is capable of organizational (1st echelon) maintenance on organic equipment; organizational (2d echelon) maintenance on motor transport equipment organic to the maintenance battalion, except for that belonging to the H&S company and the general support maintenance company;

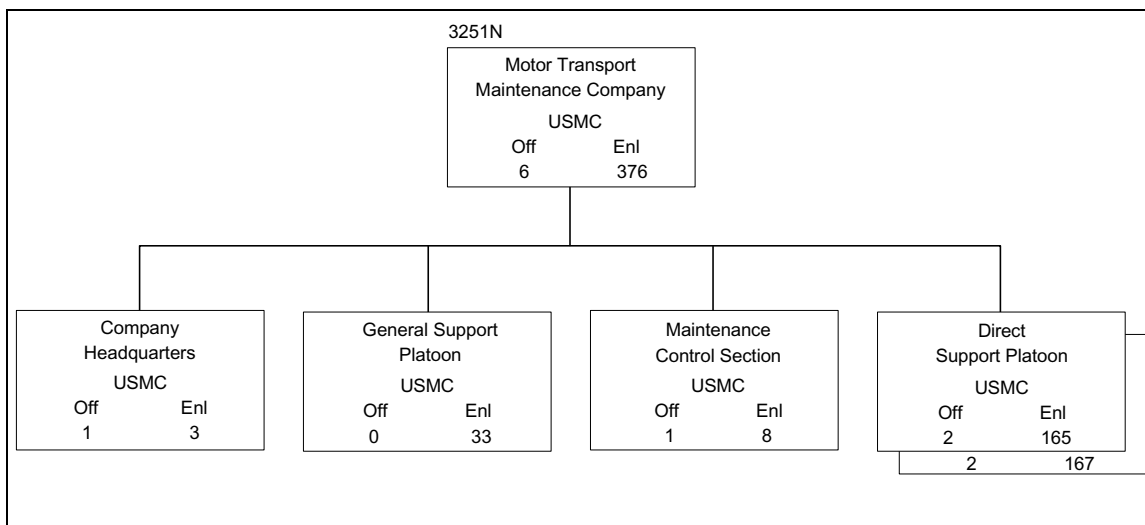

Figure 5-12. Motor Transport Maintenance Company, Maintenance Battalion.

and intermediate (3d and 4th echelon) maintenance on Marine Corps-furnished motor transport equipment of the MEF.

(3) Transportation. The motor transport maintenance company is capable of organic transportation support for command and administrative purposes and heavy transportation support to effect the evacuation of motor transport equipment.

(4) General Engineering. Engineering support, as required, is provided by the engineer support battalion.

(5) Health Services. Medical support is provided by H&S battalion, and dental support is provided by the dental battalion.

(6) Services. Services support, as required, is provided by the service company of the H&S battalion.

(7) Messing. Food service support is provided by the headquarters company of the H&S battalion.

(8) Selected Items of Equipment. See table 5-10.

5014. General Support Maintenance Company, Maintenance Battalion

a. Mission

The general support maintenance company provides general support intermediate (3d and 4th echelon) maintenance support, including component rebuilding for Marine Corps-furnished ground equipment of a MEF, except for

communications-electronics equipment and fire control components.

b. Tasks

- w Provide intermediate (3d and 4th echelon) maintenance on secondary repairables from the repairable issue point.
- w Provide body and fender maintenance and machine shop facilities for the accomplishment of intermediate (3d and 4th echelon) maintenance.
- w Prepare in-stock items for issue.

c. Concept of Organization

The company is structured to provide the appropriate technical and supervisory personnel and equipment to augment the maintenance elements of a CSSE with a general support intermediate maintenance capability. It is organized to facilitate the task organization of general support maintenance assets for support of a MEF or up to four MEUs deployed in widely separated geographical areas. (See figure 5-13 on page 5-28.)

(1) Command and Control. The company commander directs and controls command support functions relating to operations, administration, and logistics/CSS for the company.

(2) Firepower. Organic firepower capability is limited to individual and crew-served weapons for personal and local security.

TAM Number	Item	Quantity
B2130	Tank, fabric, collapsible, 3,000 gal	4
D0190	Lubricating and servicing unit, power	1
D0209	Power unit, front, 12 1/2 ton, MK48	3
D0877	Trailer, powered, wrecker/recovery, MK15	3
D0880	Trailer, tank, water, 400 gal, M149A1	2
D1158	Truck, utility, 1 1/4 ton, M998	8
D1212	Truck, wrecker, M936	3

Table 5-10. Selected Items of Equipment for the Motor Transport Maintenance Company.

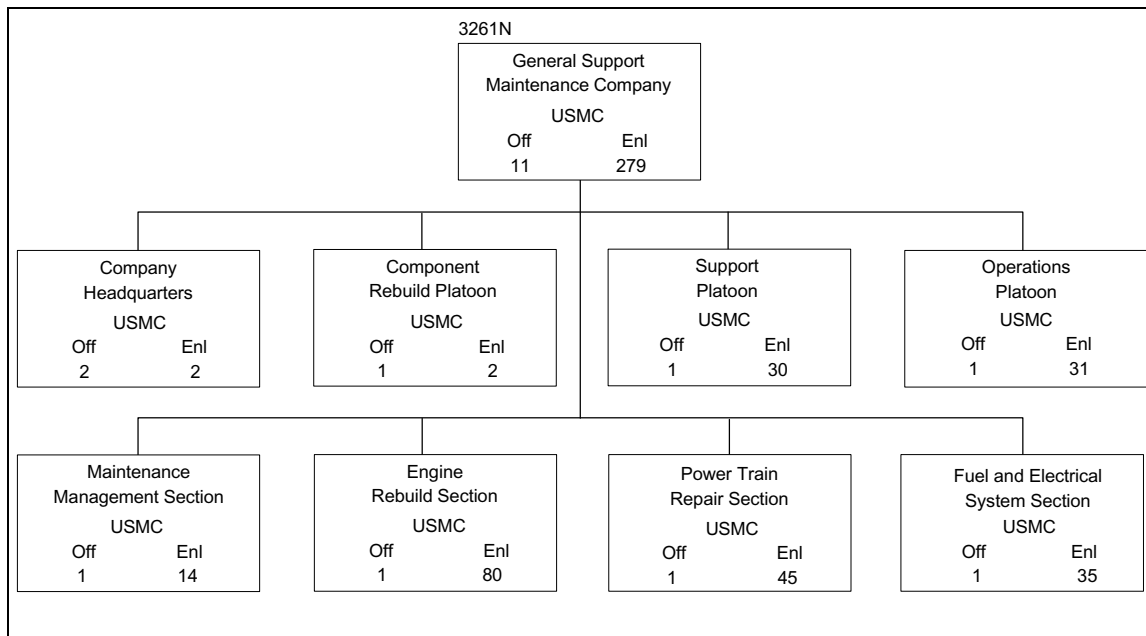

Figure 5-13. General Support Maintenance Company.

(3) Mobility. Organizational vehicles of the company provide limited mobility. Transportation support is required from the motor transport battalion to effect displacement.

(4) Communications. Communications support, as required, is provided by the communications company of the H&S battalion.

d. Concept of Employment

When operating as a unit under centralized control in the FCSSA or under decentralized control from two CSSAs, the company operates general support intermediate (3d and 4th echelon) maintenance repair facilities for the repair of Marine Corps-furnished ground equipment of the MEF, except for communications-electronics equipment.

e. Administrative Capability

Administrative support is provided by the consolidated administrative section of the H&S company of the maintenance battalion.

f. Logistic Capabilities

(1) Supply. Supply support is provided by the H&S company of the maintenance battalion.

(2) Maintenance. The general support maintenance company is capable of organizational (1st and 2d echelon) maintenance on organic equipment and intermediate (3d and 4th echelon) maintenance support for ground equipment of the MEF, except for communications-electronics equipment.

(3) Transportation. The company is capable of organic transportation support for command and administrative purposes.

(4) General Engineering. Engineering support, as required, is provided by the engineer support battalion.

(5) Health Services. Medical support is provided by H&S battalion, and dental support is provided by the dental battalion.

(6) Services. Services support, as required, is provided by the service company of the H&S battalion.

(7) Messing. Food service support is provided by the headquarters company of the H&S battalion.

(8) Selected Items of Equipment. See table 5-11.

5015. Supply Battalion

a. Mission

The supply battalion provides general support supply support, except for bulk fuel and Navy-funded stock/ programs, for sustaining MAGTF operations.

b. Tasks

- w Provide supply support management, for the FSSG and other MEF elements beyond organic capabilities of supported units, including the following stock control functions:
 - { Management of the MEF’s special allowance training pool items and initial issue provisioning assets
 - { Management of the MEF’s secondary repairables through the maintenance float
 - { Technical management, data research, customer service, and general assistance to the MEF for supply matters
 - { Supplying status management reports for the MEF, as required
 - { Interface for the MEF with financial and maintenance management systems.
- w Provide contracting support and cross servicing services for supported units, as required.
- w Provide a warehousing capability in support of the MEF.

- w Provide accounting for classes I, II, IV, VII, VIII, and IX supplies, initial issue provisioning assets, and authorized levels of war reserve.
- w Provide subsistence support to the MEF, including operation of class I subsistence dumps and storage, issue, and accounting for subsistence items.
- w Provide receipt, storage, and forwarding of class III (packaged) supplies.
- w Provide receipt, storage, issue, and accounting functions for class V items.
- w Provide technical assistance in receipt, storage, assembly, and provision of nuclear ordnance.
- w Provide for the receipt, storage, issue, and organizational (2d echelon) and intermediate (3d and 4th echelon) maintenance support for class VIII supplies and equipment.
- w Provide intermediate-level shop stores issue points for the MEF.
- w Provide procurement services for the MEF for items decentralized by the integrated materiel manager.
- w Provide packing, preservation, and packaging (PP&P) services.

c. Concept of Organization

TAM		
Number	Item	Quantity
A2167	Radio set, AN/VRC-88A	2
B0005	Air conditioner, MCS, vertical, A/E 32C-24	10
B1945	Shop equipment, contact maintenance	3
B2685	Welding machine, arc, trailer mounted	4
D0880	Trailer, tank, water, 400 gal, M149A1	1
D1061	Truck, cargo, 5 ton, XLWB, with winch, M928	3
D1212	Truck, wrecker, 5T, M936	1
D1158	Truck, utility, 1 1/4 ton, M998	6
D1212	Truck, wrecker, M936	1

Table 5-11. Selected Items of Equipment for the General Support Maintenance Company.

The battalion is organized to provide commodity-oriented, task-organized detachments for the sustainment of MAGTF operations. (See figure 5-14.)

(1) Command and Control. The battalion commander exercises command and control of the battalion through the battalion staff and the company commanders. He directs and controls command support functions relating to operations, administration, and logistics/CSS for the battalion.

(2) Firepower. Organic firepower capability is limited to individual and crew-served weapons for personal and local security.

(3) Mobility. Organizational vehicles of the company provide limited mobility. Transportation support is required from the motor transport battalion to effect displacement.

(4) Communications. Communications support is provided by the communications company of the H&S battalion.

(5) Intelligence. Intelligence support is provided by the H&S battalion.

(6) Security. The battalion is capable of limited local security.

d. Concept of Employment

The battalion consolidates the intermediate supply capabilities of the FSSG. Commodity-oriented detachments are

task organized to support MAGTF requirements. When supporting the entire MEF, supply management and control are centralized in the Supported Activities Supply System (SASSY) of the supply management unit, which is part of the supply company of the supply battalion.

e. Administrative Capability

The battalion is capable of self administration.

f. Logistic Capabilities

(1) Supply. The battalion is capable of organic supply support and general support supply support of the MEF beyond the organic capabilities of supported units.

(2) Maintenance. The battalion is capable of organizational (1st and 2d echelon) maintenance on organic equipment and intermediate (3d and 4th echelon) maintenance on medical and dental equipment of the MEF. Intermediate (3d and 4th echelon) maintenance support for nonmedical/nondental equipment is provided by the maintenance battalion.

(3) Transportation. The battalion is capable of organic transportation support for command and administrative purposes.

(4) General Engineering. Engineering support, as required, is provided by the engineer support battalion.

(5) Health Services. Medical support is provided by

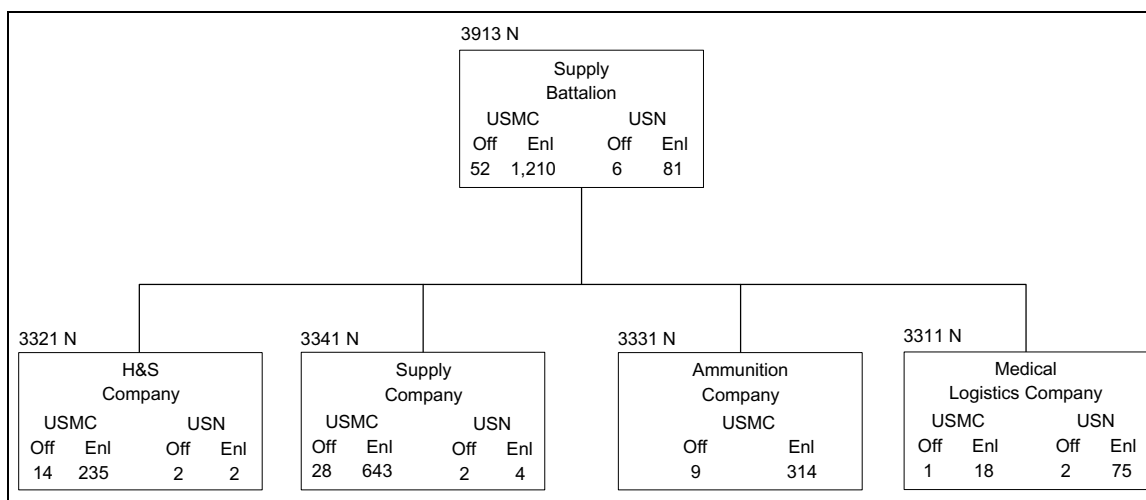

Figure 5-14. Supply Battalion.

H&S battalion, and dental support is provided by the dental battalion.

(6) Services. Services support, as required, is provided by the service company of the H&S battalion.

(7) Messing. Food service support provided by the headquarters company of the H&S battalion.

5016. Headquarters and Service Company, Supply Battalion

a. Mission

The H&S company of the supply battalion provides command and control, administration, and command support functions for the supply battalion and general support subsistence supply support to the MEF. (See table 5-12.)

b. Tasks

- w Provide direct support supply support for the battalion.
- w Provide direct support transportation support, within capabilities, for the internal transportation requirements of the battalion.
- w Provide a PP&P capability, as required, for MAGTFs.
- w Provide subsistence support to the MEF, including operation of class I subsistence dumps and storage, issue, and accounting for subsistence items.

c. Concept of Organization

	Marine Officer	Marine Enlisted	Navy Officer	Navy Enlisted
Battalion headquarters	11	80	0	0
Motor transport/maintenance platoon	1	95	0	0
Company headquarters	2	3	2	2
Direct support rations platoon (2)	0	29	0	0
Total	14	236	2	2

Table 5-12. Personnel of the H&S Company of the Supply Battalion.

The company is organized to plan, coordinate, and supervise the command support functions of the battalion and to provide specified general support supply functions for MAGTFs. It is structured to facilitate task organization of detachments for operations conducted by the battalion in support of MAGTF operations. (See figure 5-15 on page 5-32.)

(1) Command and Control. The company commander directs and controls command support functions relating to operations, administration, and logistics/CSS for the company.

(2) Firepower. Organic firepower capability is limited to individual and crew-served weapons for personal and local security.

(3) Mobility. Organizational vehicles of the company provide limited mobility. Transportation support is required from the motor transport battalion to effect displacement.

(4) Communications. Communications support, as required, is provided by the communications company of the H&S battalion.

d. Concept of Employment

The company is structured to provide task-organized detachments in support of MAGTF operations.

e. Administrative Capabilities

The company is capable of self administration and contains the consolidated administration section for the supply battalion.

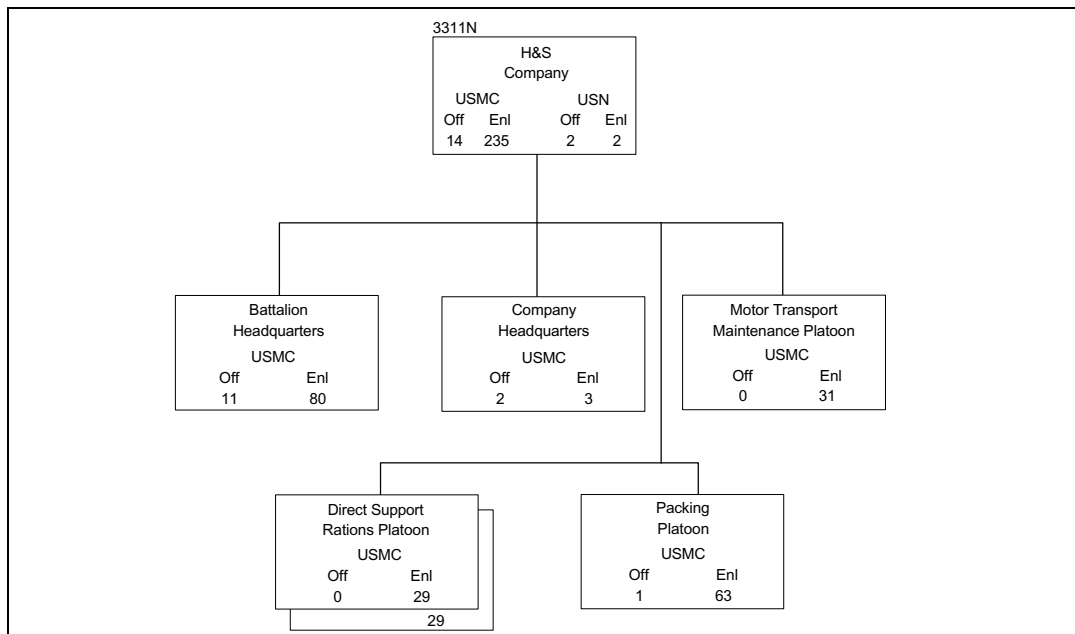

Figure 5-15. H&S Company, Supply Battalion.

f. Logistic Capabilities

(1) Supply. The company is capable of organic supply support for the battalion.

(2) Maintenance. The company is capable of organizational (1st and 2d echelon) maintenance on organic equipment. Intermediate (3d and 4th echelon) maintenance support is provided by the maintenance battalion.

(3) Transportation. The company is capable of organic transportation support to the battalion for command and administrative purposes and for the internal transportation requirements of the battalion.

(4) General Engineering. Engineering support, as required, is provided by the engineer support battalion.

(5) Health Services. Medical support is provided by the H&S battalion, and dental support is provided by the dental battalion.

(6) Services. Services support, as required, is provided by the service company of the H&S battalion.

(7) Messing. Food service support is provided by the headquarters company of the H&S battalion.

(8) Selected Items of Equipment. See table 5-13.

5017. Supply Company, Supply Battalion

a. Mission

The supply company provides general support supply support, including supply management and control, to sustain the operations of the MEF.

b. Tasks

w Provide supply support management and control for the MEF through the supply management unit, including the following stock control functions:

- { Technical management data research, customer service, and assistance to the MEF
- { Management of special allowance training pool items and initial issue provisioning assets
- { Management of secondary repairable items through the maintenance float
- { Submission of required supply status management reports to higher headquarters

TAM Number	Item	Quantity
B1291	Decontaminating system, M1731	8
D0190	Lubricating and servicing unit, power	1
D0850	Trailer, cargo, 3/4 ton, two wheel, M101A1	9
D0860	Trailer, cargo, 1 1/2 ton, two wheel, M105A2	3
D0880	Trailer, tank, water, 400 gal, M149A1	11
D1061	Truck, cargo, 5 ton, XLWB, with winch, M928	2
D1082	Truck, firefighting, 1 1/4 ton, 4 x 4, M1028	6
D1158	Truck, utility, 1 1/4 ton, M998	28
D1212	Truck, wrecker, M936	1
D1059	Truck, cargo, 5 ton, M923	4
E0980	Machine gun, .50 cal, M2	8
E0989	Machine gun, 7.62 mm, M240G	3
E0994	Machine gun, 40 mm, MK19	7

Table 5-13. Selected Items of Equipment for the H&S Company of the Supply Battalion.

- { Coordination with financial and maintenance management systems
 - { Requisitioning and direct asset management support, except for maintenance, for MEF prepositioned war reserves.
 - w Provide intermediate-level supply support to the intermediate maintenance activities of the FSSG.
 - w Provide procurement services for items decentralized by the item manager.
 - w Provide civilian contracting and cross servicing functional support for deployed units.
 - w Provide accounting for classes II, IV, VII, VIII, and IX supplies, initial issue provisioning assets, and authorized levels of war reserves.
 - w Provide medium bin and bulk storage of identified general account operating stocks.
 - w Provide supply locator services for storage functions.
 - w Provide total receipt, storage, and issue support for general account operating stocks.
 - w Provide warehousing capability for deployed CSSEs.
 - w Provide receipt, storage, and forwarding of class III (packaged) supplies to MAGTF elements or CSSAs.
 - w Provide supply expeditor and an emergency supply operations center capability to elements of the MEF.
 - w Provide deployment blocks for CSSEs deploying in support of a MAGTF.
 - w Provide continuous, sustaining supply support to deployed CSSEs.
 - w Provide a technical interface with deployed elements for the transmission and processing of supply status and mechanized records.
 - w Provide cross-support procedures for deployed CSSEs.
 - w Provide technical control over the mechanized supply support system.
 - w Provide accounting and distribution for classes of supply that are force fed to the MEF.
- c. Concept of Organization**
- The company is organized to facilitate the task organization of detachments that are capable of providing control and

management of supply support to elements of the MEF or MAGTFs smaller than a MEF. (See figure 5-16.)

(1) Command and Control. The company commander directs and controls command support functions relating to operations, administration, and logistics/CSS for the company.

(2) Firepower. Organic firepower capability is limited to individual and crew-served weapons for personal and local security.

(3) Mobility. Organizational vehicles of the company provide limited mobility. Heavy motor transport support from the motor transport battalion is required to effect displacement.

(4) Communications. Communications support, as required, is provided by the communications company of the H&S battalion.

d. Concept of Employment

The company is structured to provide centralized supply control and management for the supply battalion of the FSSG and the MEF through the supply management unit, which is capable of accounting for all classes of supply. The officer in charge of the supply management unit directs and controls external supply support and internal supply management unit operations. Processing support is provided by the local regional automated service centers.

e. Administrative Capability

Administrative support for the company is provided by the consolidated administration section of the H&S company of the supply battalion.

f. Logistic Capabilities

(1) Supply. Supply support is provided by the H&S company of the supply battalion.

(2) Maintenance. The company is capable of organizational (1st echelon) maintenance on organic equipment. Organizational (2d echelon) maintenance support is provided by the H&S company of the supply battalion, and

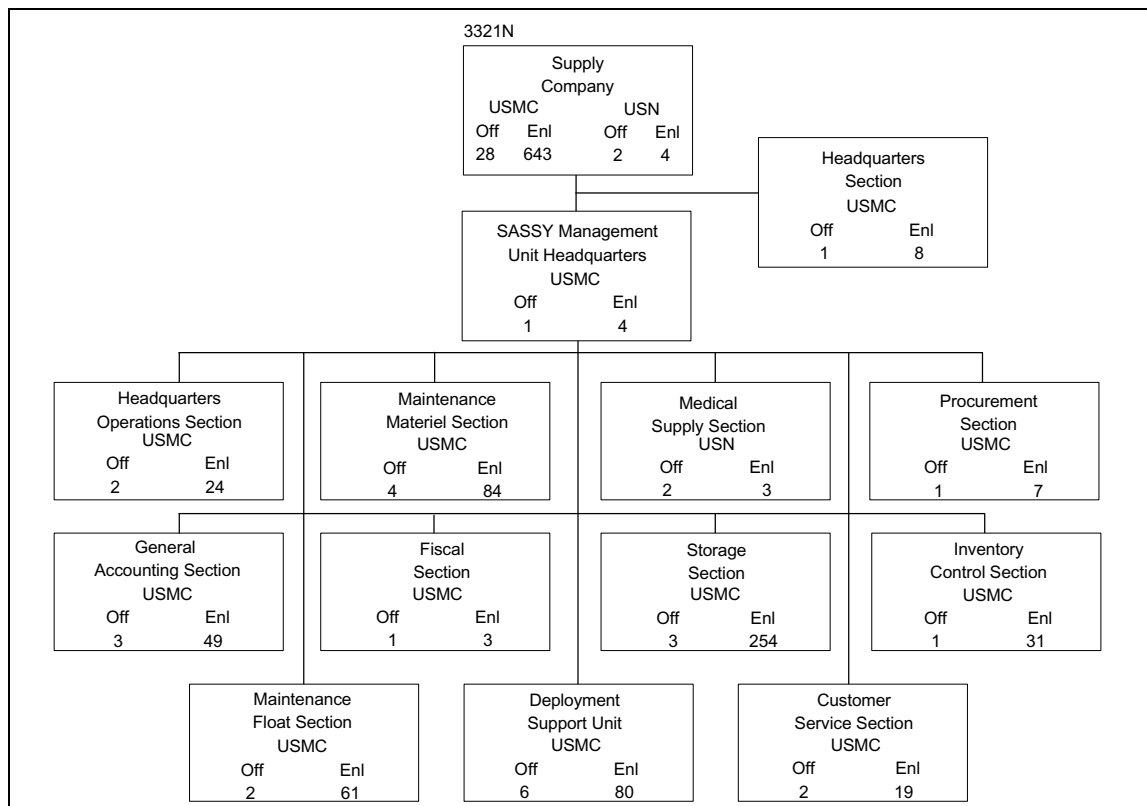

Figure 5-16. Supply Company, Supply Battalion.

intermediate (3d and 4th echelon) maintenance support is provided by the maintenance battalion.

(3) Transportation. The company is capable of organic transportation support for command and administrative purposes.

(4) General Engineering. Engineering support, as required, is provided by the engineer support battalion.

(5) Health Services. Medical support is provided by H&S battalion, and dental support is provided by the dental battalion.

(6) Services. Services support, as required, is provided by the service company of the H&S battalion.

(7) Messing. Food service support is provided by the headquarters company of the H&S battalion.

(8) Selected Items of Equipment. See table 5-14.

5018. Ammunition Company, Supply Battalion

a. Mission

The ammunition company provides general support, class V supply support to the MEF.

b. Tasks

- w Provide receipt, storage, issue, and accounting functions for class V items.
- w Provide minor rework of grade III ammunition and repackaging support for the MEF.

w Provide technical assistance in the receipt, storage, assembling, and forwarding of nuclear ordnance to ground and aviation elements of the MEF.

w Provide handling and forwarding of class V(A) ammunition and aviation ordnance.

c. Concept of Organization

The company is organized to plan, coordinate, and supervise class V support functions. It is structured to facilitate task organization of detachments for operations conducted by the supply battalion in support of the MEF and any combination of smaller MAGTFs. (See figure 5-17 on page 5-36.)

(1) Command and Control. The company commander directs and controls command support functions relating to operations, administration, and logistics/CSS for the company.

(2) Firepower. Organic firepower capability is limited to individual and crew-served weapons for personal and local security.

(3) Mobility. Organizational vehicles of the company provide limited mobility. Transportation support is required from the motor transport battalion to effect displacement.

(4) Communications. Communications support, as required, is provided by the H&S battalion.

d. Concept of Employment

The company is structured to provide class V supply support to the MEF or MAGTFs smaller than a MEF. The company is capable of organizing and operating one or

TAM Number	Item	Quantity
E0980	Machine gun, .50 cal, M2	2
E0989	Machine gun, 7.62 mm, M240G	8
E0994	Machine gun, 40 mm, MK19	4

Table 5-14. Selected Items of Equipment for the Supply Company of the Supply Battalion.

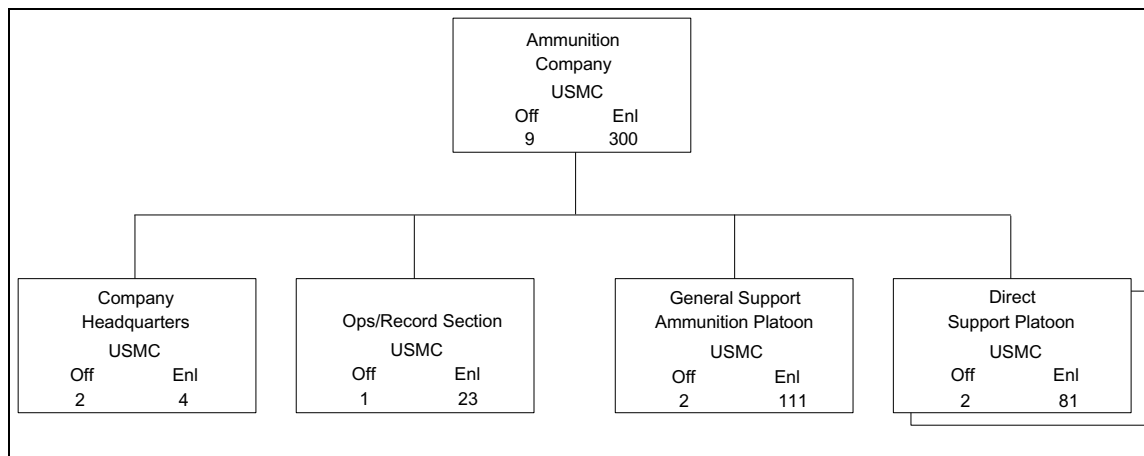

Figure 5-17. Ammunition Company, Supply Battalion.

more ammunition supply points in one or more CSSAs in support of MEF operations.

e. Administrative Capability

Administrative support is provided by the consolidated administration section of the H&S company of the supply battalion.

f. Logistic Capabilities

(1) Supply. Supply support is provided by the H&S company of the supply battalion.

(2) Maintenance. The company is capable of organizational (1st echelon) maintenance on organic equipment. Organizational (2d echelon) maintenance support is provided by the H&S company of the supply battalion. Intermediate (3d and 4th echelon) maintenance support is provided by the maintenance battalion.

(3) Transportation. The company is capable of organic transportation support for command and administrative purposes. Motor transport and materials handling equipment (MHE) support are required to effect distribution of supplies.

(4) General Engineering. Engineering support, as required, is provided by the engineer support battalion.

(5) Health Services. Medical support is provided by H&S battalion, and dental support is provided by the dental battalion.

(6) Services. Services support, as required, is provided by the service company of the H&S battalion.

(7) Messing. Food service support is provided by the headquarters company of the H&S battalion.

(8) Selected Items of Equipment. See table 5-15.

5019. Medical Logistics Company, Supply Battalion

a. Mission

The medical logistics company provides general supply and maintenance support for class VIII materiel of the MEF.

b. Tasks

- w Provide general support supply support, including establishment and operation of class VIII supply points and acquisition, receipt, and issue for class VIII materiel of the MEF.
- w Provide organizational (1st and 2d echelon) and intermediate (3d and 4th echelon) maintenance support for class VIII equipment of the MEF.

TAM Number	Item	Quantity
B0472	Demolition equipment	4
E0980	Machine gun, .50 cal, M2	2
E0989	Machine gun, 7.62 mm, M240G	2
E0994	Machine gun, 40 mm, MK19	4

Table 5-15. Selected Items of Equipment for the Ammunition Company.

- w Provide support for the packing, preserving, storage, and maintenance of class VIII re-supply.
- w Provide for the receipt, storage, and issue of class VIII supplies in support of the authorized medical allowance list (AMAL)/authorized dental allowance list (ADAL) for MAGTF medical and dental units; intermediate (3d and 4th echelon) maintenance support for biomedical/technical medical and dental equipment; and 1st and 2d echelon maintenance support for MAGTF medical/dental equipment.
- w Provide technical assistance to MAGTF medical/dental units for the maintenance, inventory, and quality control of unit AMALs/ ADALs.

c. Concept of Organization

The company is organized to plan, coordinate, and supervise the command support functions of the battalion. It is structured to facilitate task organization of detachments in support of MAGTF operations. (See figure 5-18 on page 5-38.)

- (1) Command and Control.** The company commander directs and controls command support functions relating to operations, administration, and logistics/CSS for the company.
- (2) Firepower.** Organic firepower capability is limited to individual weapons for personal security.
- (3) Mobility.** Organizational vehicles of the company provide limited mobility. Transportation support is required from the motor transport battalion to effect displacement.

(4) Communications. Communications support, as required, is provided by the H&S battalion.

d. Concept of Employment

The company is structured to provide a centralized supply and maintenance facility for class VIII supplies and equipment. The supply platoons are capable of centralized operations under the medical logistics company or decentralized operations in three balanced units in support of a MEF or MAGTFs smaller than a MEF. The equipment repair platoon is capable of in-store maintenance of medical and dental equipment of the MEF and of operating in a centralized repair site and/or through decentralized, on-site maintenance support teams.

e. Administrative Capability

Administrative support for assigned Marine Corps personnel is provided by the consolidated administration section of the H&S company of the supply battalion. Administrative support for assigned Navy personnel is provided by the service company of the H&S battalion.

f. Logistic Capabilities

- (1) Supply.** The company is capable of organic supply support.
- (2) Maintenance.** The company is capable of organizational (1st echelon) maintenance on organic equipment and organizational (1st and 2d echelon) and intermediate (3d and 4th echelon) maintenance on medical and dental equipment of the MEF. For other organic nonmedical/nondental, Marine Corps-furnished equipment, organizational (2d echelon) maintenance support is provided by the H&S company of the supply battalion, and intermediate (3d and

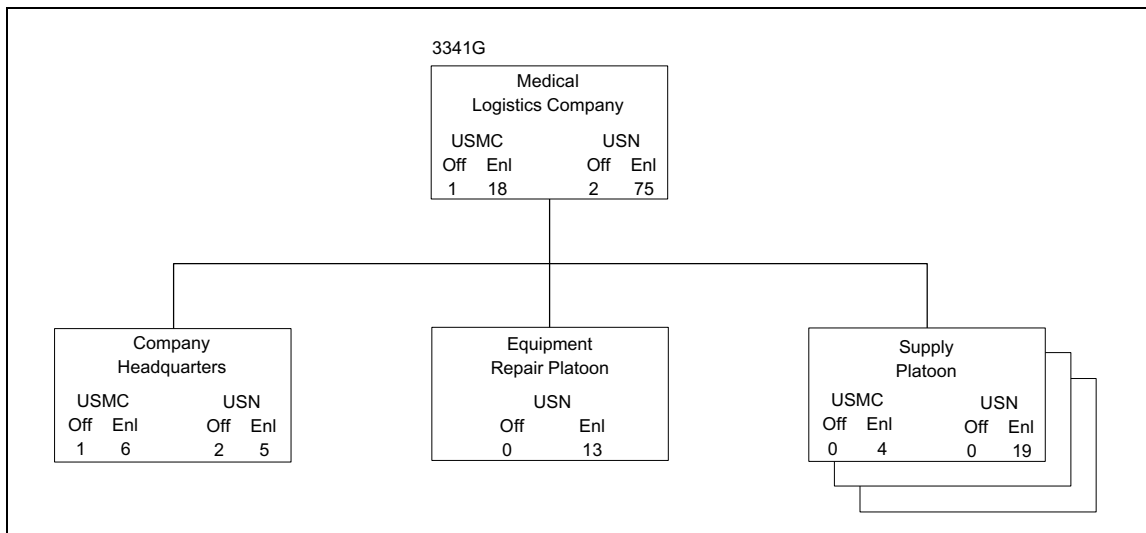

Figure 5-18. Medical Logistics Company. Supply Battalion.

4th echelon) maintenance support is provided by the maintenance battalion.

(3) Transportation. The company is capable of organic transportation support for command and administrative purposes. To effect distribution of class VIII supplies, augmentation by the motor transport battalion is required.

(4) General Engineering. Engineering support, as required, is provided by the engineer support battalion.

(5) Health Services. Medical support is provided by H&S battalion, and dental support is provided by the dental battalion.

(6) Services. Services support, as required, is provided by the service company of the H&S battalion.

(7) Messing. Food service support is provided by the headquarters company of the H&S battalion.

5020. Engineer Support Battalion

a. Mission

The engineer support battalion provides general engineering support of an expeditionary nature to the MEF, including survivability, countermobility, and mobility enhancements; EOD; and general support supply support incident to the handling, storage, dispensing of bulk class I (water) and bulk class III and III(A) items.

b. Tasks

- w Conduct engineering reconnaissance that is necessary to support the battalion's mission or other engineering needs of the MEF.
- w Construct, improve, and maintain airfields, including expeditionary airfields.
- w Construct, improve, and maintain encampments, CSSAs, and other MEF-required support facilities by using available material or preengineered structures.
- w Conduct mobility enhancement operations, including the construction, improvement, and maintenance of lines of communications and main supply routes.
- w Provide bulk class III and III(A) fuel support, including receipt, storage, and dispensing of bulk fuel products.
- w Provide utilities support, including mobile electric power beyond supported units' capabilities and electrical power distribution within camps and CSSAs.
- w Provide water purification and bulk class I (water) storage and dispensing for the FSSG and other elements of the MEF when requirements exceed supported units' capabilities.
- w Provide survivability enhancements, including the construction of protective structures.

- w Install and/or supervise other units in the installation of standard and nonstandard, fixed-panel and floating bridging, including planning and controlling bridging operations in support of MEF mobility requirements.
- w Provide bath and laundry services beyond supported units' capabilities.
- w Provide EOD support, as required, to the MEF.
- w Construct field-expedient deception devices.
- w Conduct countermobility operations through installation of obstacles and barriers, including explosive and nonexplosive obstacles.
- w Conduct mobility operations, including breaching, reducing, and removing explosive or nonexplosive obstacles.
- w Provide specialized demolition operations beyond supported units' capabilities.

MEF or combinations of smaller MAGTFs. (See figure 5-19.)

(1) Command and Control. The battalion commander exercises command and control of the battalion through the battalion staff and the company commanders. He directs and controls command support functions relating to operations, administration, and logistics/CSS for the battalion.

(2) Firepower. Organic firepower capability is limited to individual and crew-served weapons for personal and local security.

(3) Mobility. Organizational vehicles of the company provide limited mobility and, largely, are not helicopter-transportable. Transportation support is required from the motor transport battalion to effect displacement and to support construction operations involving large quantities of class IV materials.

c. Concept of Organization

The battalion is organized to plan, coordinate, and supervise the general engineering and supply support functions of the battalion. It is structured to facilitate task organization for operations conducted by the battalion in support of the

(4) Communications. The battalion is capable of single-channel communications. Communications support, as required, is provided by the communications company of the H&S battalion.

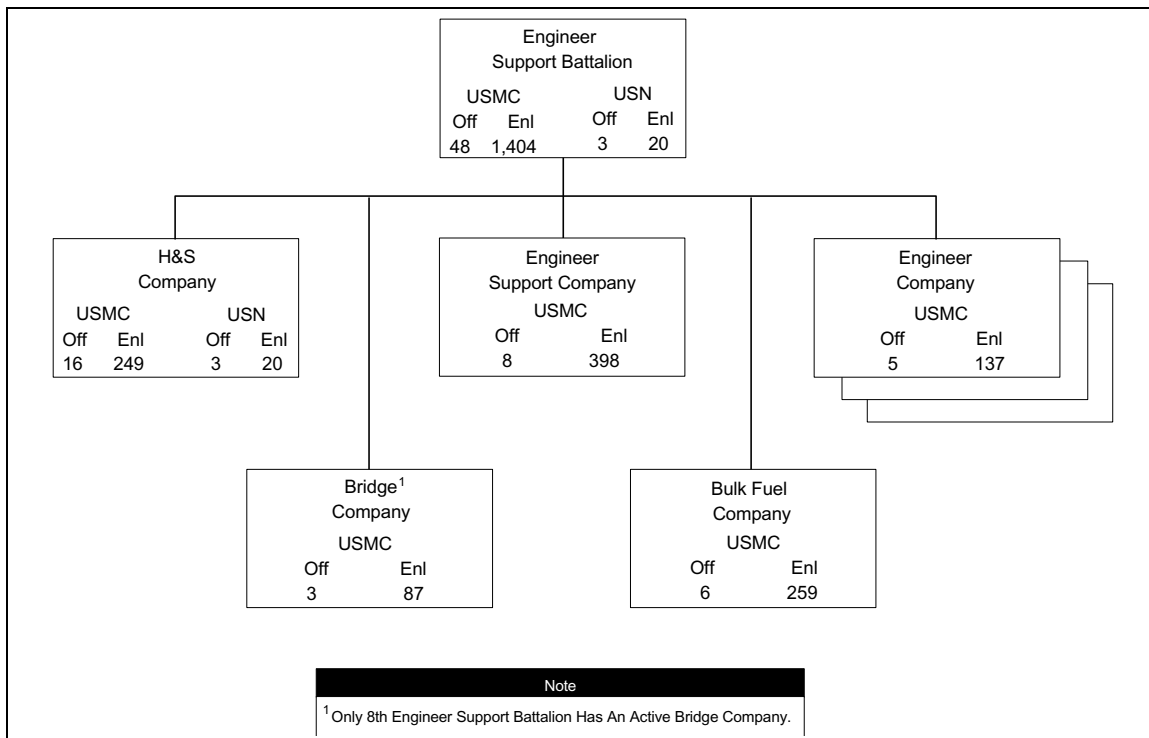

Figure 5-19. Engineer Support Battalion.

(5) Intelligence. Intelligence support, as required, is provided by the H&S battalion. The battalion provides engineer intelligence to the FSSG.

(6) Security. The battalion is capable of limited security support functions. Security support, as required, is provided by the H&S battalion.

d. Concept of Employment

The battalion is normally employed as a complete unit in general support of the MEF under the control of the battalion commander. Engineer companies may be detached or task organized in support of a specific operation or unit. When assuming missions normally handled by engineer units of the Marine division or aircraft wing, the assigned engineer support battalion/ engineer company will retain control of organic assets.

e. Administrative Capability

The battalion is capable of self-administration.

f. Logistic Capabilities

(1) Supply. The battalion is capable of organic supply support.

(2) Maintenance. The battalion is capable of organizational (1st and 2d echelon) maintenance on organic equipment. Intermediate (3d and 4th echelon) maintenance support is provided by the maintenance battalion.

(3) Transportation. The battalion is capable of organic transportation support for command and administrative purposes.

(4) General Engineering. The battalion is capable of organic engineering support.

(5) Health Services. The battalion is capable of organic medical support. Dental support is provided by the dental battalion.

(6) Services. Services support, as required, is provided by the service company of the H&S battalion.

(7) Messing. The battalion is capable of organic food service support.

5021. Headquarters and Service Company, Engineer Support Battalion

a. Mission

The H&S company provides command and control, administration, and command support functions for the engineer support battalion and EOD support to the MEF.

b. Tasks

- w Provide, within capabilities, command support and logistics support functions, including single-channel communications, medical, food service, and chaplain support, for the battalion.
- w Operate the organic supply account in support of the battalion.
- w Provide EOD support to the MEF.

c. Concept of Organization

The company is organized to plan, coordinate, and supervise the command support functions for the battalion. It is structured to facilitate task organization for operations conducted by the battalion in support of MAGTF operations. (See figure 5-20.)

(1) Command and Control. The company commander directs and controls command support functions relating to operations, administration, and logistics/CSS for the company.

(2) Firepower. Organic firepower capability is limited to individual and crew-served weapons for personal and local security.

(3) Mobility. Organizational vehicles of the company provide limited mobility. Transportation support is required from the engineer support company of the engineer support battalion to effect displacement.

(4) Communications. The company is capable of limited organic communications support. Augmentation is required to support the EOD/nuclear weapons platoon and the bulk fuel company.

d. Concept of Employment

The company provides the necessary command, control, and command support functions for the coordination of battalion operations and to support reinforced engineer companies.

e. Administrative Capability

The company is capable of self-administration and contains the consolidated administration section for the engineer support battalion.

f. Logistic Capabilities

(1) Supply. The company is capable of organic supply support.

(2) Maintenance. The company is capable of organizational (1st echelon) maintenance on organic equipment and organizational (2d echelon) maintenance on organic ordnance, surveying, and communications-electronics equipment. Intermediate (3d and 4th) maintenance support is provided by the maintenance battalion.

(3) Transportation. The company is capable of transportation support for command and administrative purposes. Transportation support, as required, is provided by the engineer support company of the engineer support battalion.

(4) General Engineering. Engineering support, as required, is provided by appropriate companies of the engineer support battalion.

(5) Health Services. The company is capable of organic medical support for the battalion with augmentation, as required, provided by the H&S battalion. Dental support is provided by the dental battalion.

(6) Services. Services support, as required, is provided by the service company of the H&S battalion.

(7) Messing. The company is capable of organic food service support for the battalion.

(8) Selected Items of Equipment. See table 5-16.

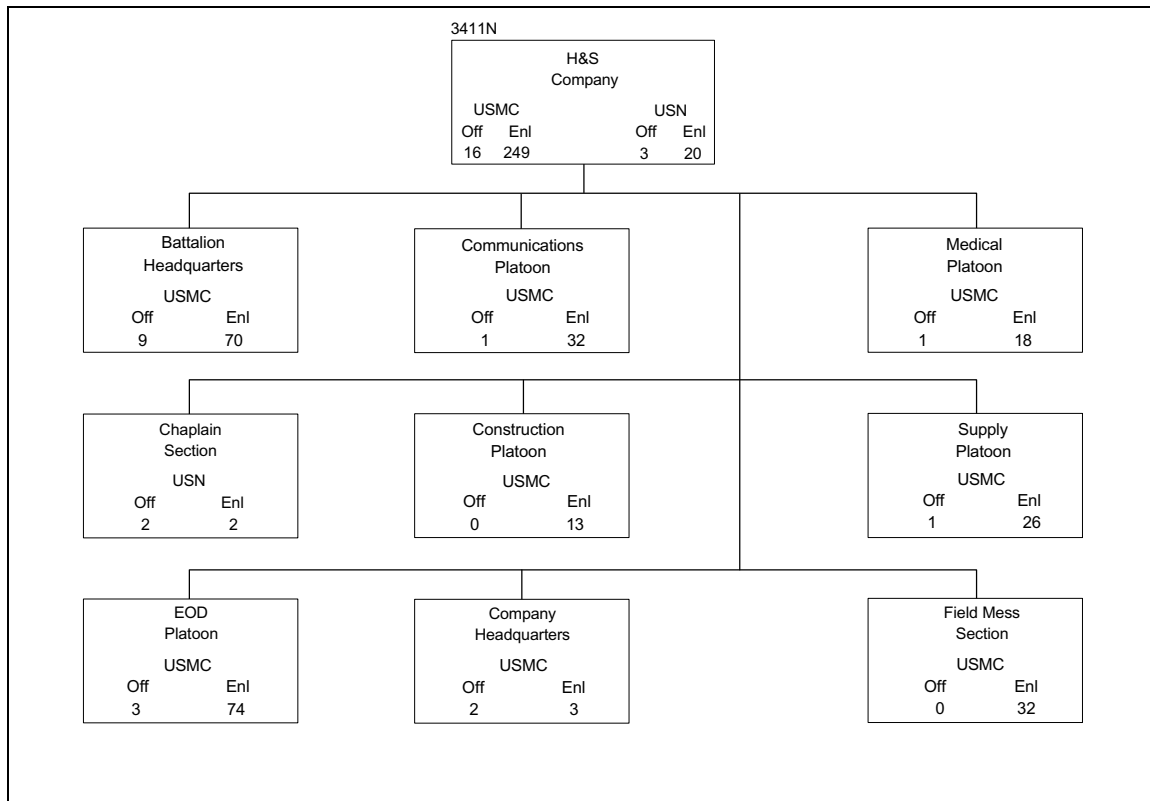

Figure 5-20. H&S Company, Engineer Support Battalion.

5022. Engineer Support Company, Engineer Support Battalion

a. Mission

The engineer support company provides direct support maintenance support for specified equipment that is organic to the battalion, direct support transportation and services support to the battalion, and general support/reinforcing augmentation, as required, to the engineer companies of the battalion in support of the MEF operations.

b. Tasks

- w Provide maintenance support for the motor transport and engineer equipment of the battalion.
- w Provide transportation support to elements of the battalion, as required.
- w Provide services support to the battalion, including bath and laundry services, water supply, and mobile electric power.

- w Provide equipment and operator augmentation to the engineer companies, as required, including heavy engineer, utilities, and motor transport support.

c. Concept of Organization

The company is organized to plan, coordinate, and supervise the command support functions for the company and to facilitate task organization for engineer maintenance support for operations conducted by the battalion in support of MAGTF operations. (See figure 5-21.)

(1) Command and Control. The company commander directs and controls command support functions relating to operations, administration, and logistics/CSS for the company.

(2) Firepower. Organic firepower capability is limited to individual and crew-served weapons for personal and local security.

TAM Number	Item	Quantity
A1957	Radio set, AN/MRC-145	9
A2069	Radio set, AN/PRC-113	2
A1935	Radio set, AN/MRC-138	9
A2070	Radio set, AN/PRC-119	29
A2065	Radio set, AN/PRC-104	4
A2167	Radio set, AN/VRC-88A	9
A2169	Radio set, AN/VRC-90	1
A2480	Switchboard, telephone, manual, SB-22/PT	8
B0565	Driver set, ramset	2
B2120	Surveying set, general purpose	1
D1002	Truck, ambulance, M1035	1
D1158	Truck, cargo, M998	3

**Table 5-16. Selected Items of Equipment for the H&S Company
of the Engineer Support Battalion.**

(3) Mobility. Organizational vehicles of the company provide limited mobility. Transportation support is required from the motor transport battalion to effect displacement.

(4) Communications. Communications support is provided by the communications platoon of the H&S company of the engineer support battalion.

d. Concept of Employment

The company provides maintenance support for organic equipment of the battalion, except for ordnance and communications-electronics equipment. It augments other companies of the battalion with engineer equipment and operators and motor transport assets, as required. It may also reinforce the engineer companies with water supply and electrical utilities equipment.

e. Administrative Capability. Administrative support is provided by the consolidated administration section of the H&S company of the engineer support battalion.

f. Logistic Capabilities

(1) Supply. Supply support is provided by the H&S company of the engineer support battalion.

(2) Maintenance. The company is capable of organizational (1st echelon) maintenance on organic equipment;

organizational (2d echelon) maintenance on organic equipment, except for communications electronics, ordnance, EOD, and bulk fuel equipment held by engineer support battalion; and intermediate (3d echelon) maintenance on bridge equipment and boats. The maintenance battalion provides organizational (2d echelon) and intermediate (3d and 4th echelon) maintenance support, as required, for other organic equipment except for bridging and boats.

(3) Transportation. The company is capable of organic transportation support, as required, for elements of the engineer support battalion.

(4) General Engineering. Engineering support, as required, is provided by appropriate companies of the engineer support battalion.

(5) Health Services. Medical support, is provided by the H&S company of the engineer support battalion, and dental support is provided by the dental battalion.

(6) Services. Services support, as required, is provided by the service company of the H&S battalion.

(7) Messing. Food service support is provided by the H&S company of the engineer support battalion.

(8) Selected Items of Equipment. See table 5-17.

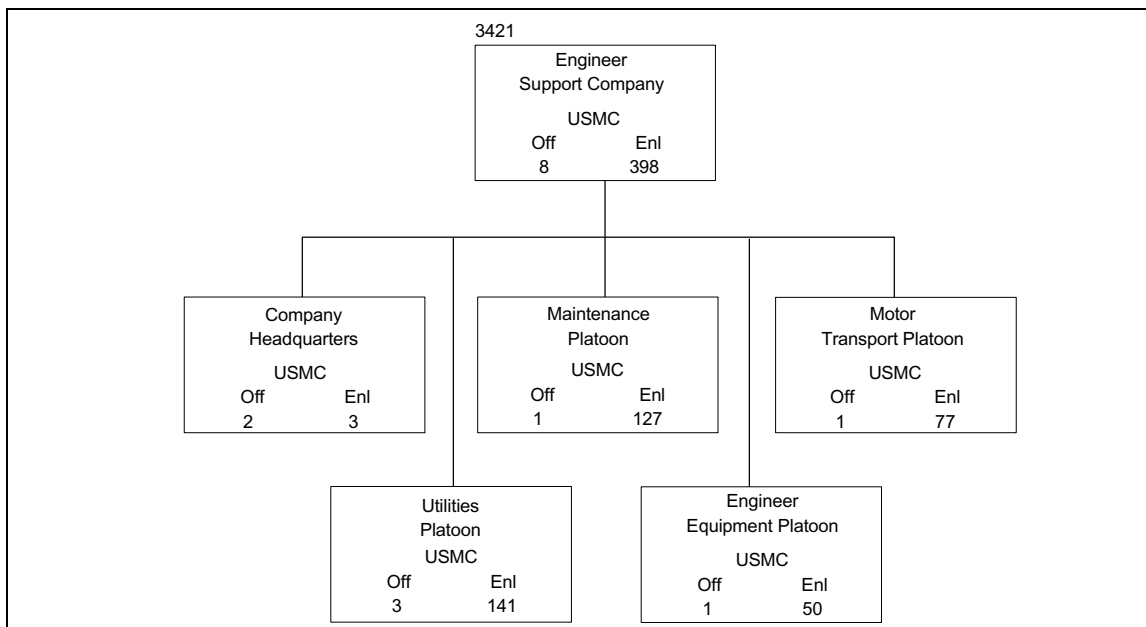

Figure 5-21. Engineer Support Company, Engineer Support Battalion.

5023. Bridge Company, Engineer Support Battalion

a. Mission

The bridge company provides general support standard tactical bridging support to enhance the tactical mobility of the MEF.

b. Tasks

- w Provide technical assistance/supervision for the construction of fixed-panel and floating bridge equipage.
- w Maintain bridging equipment.

c. Concept of Organization

The company is organized to plan, coordinate, and supervise bridging support operations of the battalion. It is structured to facilitate task organization for bridging operations conducted by the battalion in support of the MEF or any combination of smaller MAGTFs. (See figure 5-22 on page 5-46.)

(1) Command and Control. The company commander directs and controls command support functions relating to operations, administration, and logistics/CSS for the company.

(2) Firepower. Organic firepower capability is limited to individual and crew-served weapons for personal and local security.

(3) Mobility. Organizational vehicles of the company provide limited mobility. Transportation support is required from the engineer support battalion to effect displacement.

TAM Number	Item	Quantity
B0055	Bath/shower, expeditionary unit (replaces B0060)	15
B1071	Bucket, clamshell, 3/4-yd capacity	3
B0176	Bucket, concrete, horizontal discharge	2
B0395	Compressor, air, rotary, 250 ft/min	3
B0443	Crane, high speed, high mobility	4
B0446	Crane, rough terrain, hydraulic, light	4
B0525	Drawbar attachment, fixed rear mount	6
B0579	Dummy load, generator set, electric, 100 kW	2
B0589	Excavator, combat M9 ACE	5
B0635	Floodlight set, skid-mtd w/toner	35
B0730	Generator set, 3 kW, 60 Hz, skid mounted, MEP-016A	35
B0891	Generator set, 10 kW, 60 Hz, skid mounted, MEP-803A	70
B0953	Generator set, 30 kW, 60 Hz, skid mounted, MEP-805A	55
B1021	Generator set, 60 kW, 60 Hz, skid mounted, MEP-806A	35
B1045	Generator set, 100 kW, 60 Hz, skid mounted, MEP-007B	4
B1082	Grader, road, motorized, 130G	4
B1140	Hypochlorination unit, purification	3
B1220	Kit, assault trackway	30
B1226	Laundry unit, field	10
B1326	Mixer, concrete	3
B1581	Pump module, water	15
B1620	Pump set, 65 GPM, 50-ft head	18
B1645	Refrigeration unit, F/rigid box	3
B1710	Refrigerator, rigid box 350 cu ft	3
B1775	Ripper attachment, three shank, rear mounting	3

Table 5-17. Selected Items of Equipment for the Engineer Support Company.

(4) Communications. Communications support, as required, is provided by the H&S company of the engineer support battalion.

d. Concept of Employment

The bridge company normally operates under the centralized control of the engineer support battalion in general

(1) Supply. Supply support is provided by the H&S company of the engineer support battalion.

(2) Maintenance. The company is capable of organizational (1st echelon) maintenance on organic equipment and organizational (1st and 2d echelon) maintenance on bridge-peculiar equipment. Intermediate (3d echelon) maintenance support for bridging equipment is provided by the engineer support company of the engineer support battalion, and

Table 5-17 (continued). Selected Items of Equipment for the Engineer Support Company.

TAM Number	Item	Quantity
B1785	Roller, compactor, vibrator	4
B1922	Scraper, tractor, wheeled, 621 B	6
B1945	Shop equipment, contact maint, trk-mtd	2
B2086	Storage tank module, water (sixcon)	75
B2130	Tank, fabric, collapsible, 3,000 gal	175
B2462	Tractor, medium, full tracked, D7G	10
B2464	Tractor, full tracked, multipurpose, MC-1150	4
B2566	Trk, forklift, RT, 4000 lb	2
B2567	Tractor, RT, articulated steer	4
B2482	Tractor, all-wheel drive	2
B2604	Water, purification unit, reverse osmosis	35
B2685	Welding machine, arc, trailer mounted, DCC-353-P	2
B2705	Winch attachment, single drum, for tractor	5
D0080	Chassis, trailer, general purpose, M353	55
D0209	Power unit, 12 1/2 ton, MK48	28
D0235	Semitrailer, low bed, 40 ton, M870	2
D0860	Trailer, cargo, 1 1/2 ton, two wheel, M105A2	13
D0877	Trailer, powered, wrecker/recovery, MK15	2
D0085	Trailer, 3/4 ton, two wheel, M116A3	25
D0878	Trailer, powered, fifth wheel, 4 x 4, MK16, MOD O	2
D1059	Truck, cargo, 5 ton, M923	2
D1072	Truck, dump, 5 ton, 6 x 6, M927	14
D1158	Truck, utility, 1 1/4 ton, M998	29

support of MEF operations.

e. Administrative Capability

Administrative support is provided by the consolidated administration section of the H&S company of the engineer support battalion.

f. Logistic Capabilities

organizational (2d echelon) and intermediate (3d and 4th echelon) maintenance support for other organic equipment is provided by the engineer support company and/or the maintenance battalion.

(3) Transportation. The company is capable of organic transportation support for command and administrative purposes. Transportation support is required from the engineer support battalion and/or the motor transport battal-

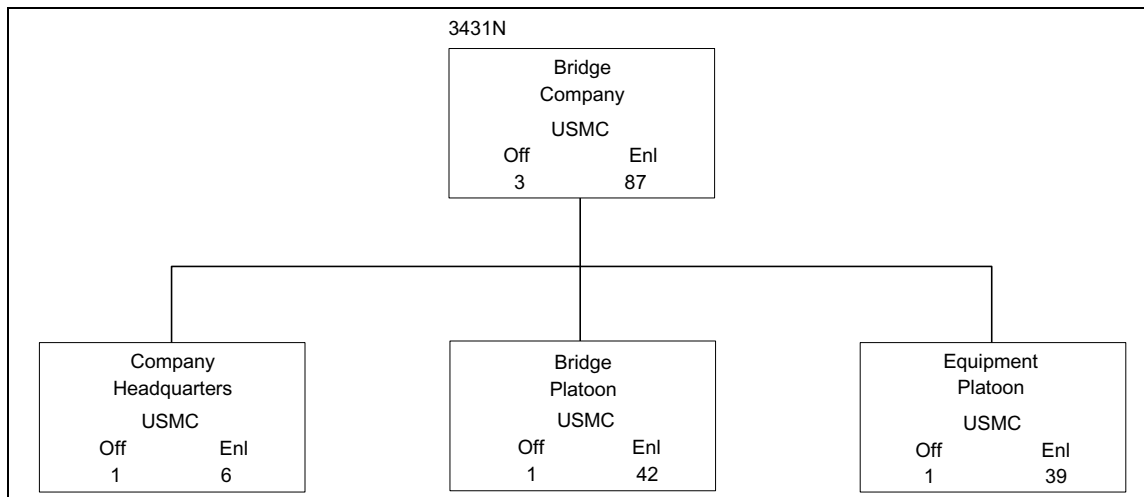

Figure 5-22. Bridge Company, Engineer Support Battalion.

ion for movement of bridging equipment in support of MAGTF operations.

(4) General Engineering. Engineering support, as required, is provided by appropriate companies of the engineer support battalion.

(5) Health Services. Medical support is provided by the H&S company of the engineer support battalion, and dental support is provided by the dental battalion.

(6) Services. Services support, as required, is provided by the service company of the H&S battalion.

(7) Messing. Food service support is provided by the H&S company of the engineer support battalion.

(8) Selected Items of Equipment. See table 5-18.

5024. Bulk Fuel Company, Engineer Support Battalion

a. Mission

Provide general support, class III supply support to the MEF, including distribution to, but not within, air bases in support of MEF operations.

b. Tasks

- w Perform those supply functions relating to the receipt, storage, and distribution of bulk class III and class III(A) supplies for the MEF.
- w Provide coordination with the MAW for transfer of class III(A) supplies to the MAW.

c. Concept of Organization

The company is organized to plan, coordinate, and supervise the bulk fuel support functions of the battalion. It is structured to facilitate task organization for bulk fuel operations conducted by the battalion in support of the MEF or any combination of smaller MAGTFs. (See figure 5-23 on page 5-48.)

(1) Command and Control. The company commander directs and controls command support functions relating to operations, administration, and logistics/CSS for the company.

(2) Firepower. Organic firepower capability is limited to individual and crew-served weapons for personal and local security.

(3) Mobility. Organizational vehicles of the company provide limited mobility. Heavy motor transport support from the engineer support battalion and/or the motor transport battalion is required to effect displacement.

TAM Number	Item	Quantity
B0114	Boat, bridge erection, BMK2	9
B0130	Bridge, fixed-floating, 60 ton, M4T6	1
B0150	Bridge, floating, foot	6
B0152	Bridge, medium girder	6
B0395	Compressor, air rotary, 250 ft/min	3
B0475	Detecting set, mine, portable, metal, AF108	3
B0635	Floodlight set, skid-mtd w/tower	3
B1620	Pump set, 65 GPM, 50-ft head	6
B1720	Reinforcement set, medium-girder bridge (MGB)	3
B1830	Saw, chain, one-man portable	4
B2060	Spray outfit, paint, 91-4500	1
B2500	Transit, 20-second, with tripod	3
B2685	Welding machine, arc, trailer mounted, DCC353P	1
W0110	Dolly trailer, converter, 6 ton, M197A1	96
D0250	Semitrailer, stake, 6 ton, two wheel, M118A1	17
D0860	Trailer, cargo, 1 1/2 ton, two wheel, M105A2	6
D0881	Trailer, ribbon bridge, MK18A1	24
D1061	Truck, cargo, 5 ton, XLWB, M928	6
D1158	Truck, utility, 1 1/4 ton, M99A	1

Table 5-18. Selected Items of Equipment for the Bridge Company.

(4) Communications. Communications support is provided by the H&S company of the engineer support battalion.

d. Concept of Employment

The company normally operates in general support of the MEF under the centralized control of the engineer support battalion commander or an engineer company commander. As a force asset, its operations may be controlled directly by the FSSG commander if the engineer support battalion commander cannot effectively exercise command and control because of geographic separation or other operational considerations.

e. Administrative Capability

Administrative support is provided by the consolidated administration section of the H&S company of the engineer support battalion.

f. Logistic Capabilities

(1) Supply. Supply support is provided by the H&S company of the engineer support battalion.

(2) Maintenance. The company is capable of organizational (1st and 2d echelon) maintenance on bulk fuel system-peculiar equipment. Organizational (2d echelon) maintenance on other organic equipment is provided by the engineer support company of the engineer support battalion. Intermediate (3d and 4th echelon) maintenance support for other equipment is provided by the engineer support company and the maintenance battalion.

(3) Transportation. The company is capable of organic transportation support for command and administrative purposes.

(4) General Engineering. Engineering support, as required, is provided by appropriate companies of the engineer support battalion.

(5) Health Services. Medical support is provided by the H&S company of the engineer support battalion, and dental support is provided by the dental battalion.

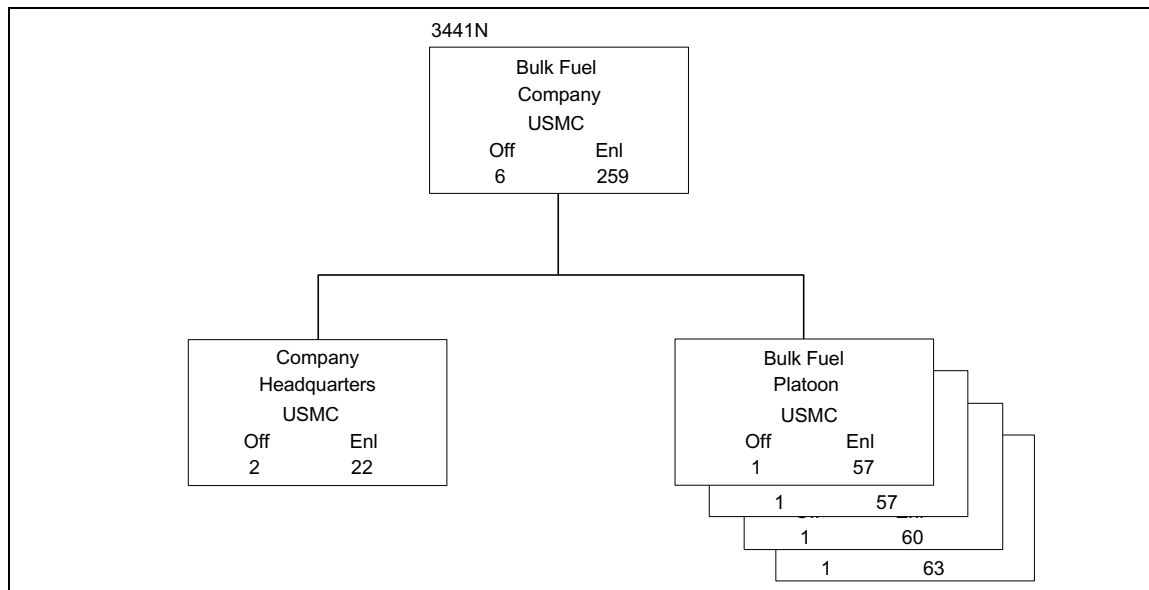

Figure 5-23. Bulk Fuel Company, Engineer Support Battalion.

(6) Services. Services support, as required, is provided by the service company of the H&S battalion.

(7) Messing. Food service support is provided by the H&S company of the engineer support battalion.

(8) Selected Items of Equipment. See table 5-19.

5025. Engineer Company, Engineer Support Battalion

a. Mission

The engineer company provides general engineering support of an expeditionary nature to the MEF.

TAM Number	Item	Quantity
B0395	Compressor, air rotary, 250 ft/min	2
B0446	Crane, RT hydraulic, light	6
B0570	Drum, fabric, collapsible, 500 gal	96
B0685	Fuel system, amphibious assault, 600,000 gal, M69HC	8
B1570	Pump assembly, expedient refueler, M-81 TDH	32
B1580	Pump module, fuel	7
B2085	Storage tank module (sixcon)	22
B2567	Tractor, RT, articulated steer	5
C4765	Extinguisher, fire, dry chemical	28
D0850	Trailer, cargo, 3/4 ton, two wheel, M101A1	4
D0880	Trailer, tank, water, 400 gal, M149A1	4
D1082	Truck, firefighting, 1 1/4 ton, 4 x 4, M1028FF	8
D1158	Truck, utility, 1 1/4 ton, M998	13

Table 5-19. Selected Items of Equipment for the Bulk Fuel Company.

b. Tasks

- w Conduct engineering reconnaissance.
- w Repair, stabilize, and reinforce airfield taxiways and runways within organizational capabilities.
- w Provide site preparation, installation, repair, and maintenance of expeditionary airfields.
- w Construct, repair, and maintain lines of communications and main supply routes; this includes deliberate detection and clearance of mines.
- w Provide vertical construction, including concrete work and erection of prefabricated buildings, towers, and hangars.
- w Construct troop cantonments.
- w Establish expedient landing zones.
- w Conduct standard and non-standard bridging operations with augmentation from the engineer support battalion and/or supported units of the MEF.
- w Conduct construction surveys and prepare drafting designs in support of the construction mission.
- w Provide survivability enhancements, including field fortifications and fighting-vehicle defensive positions.
- w Conduct countermobility operations, including emplacement of obstacles, minefields, and barriers.

- w Conduct mobility operations, including obstacle reduction and breaching and specialized demolition tasks.

c. Concept of Organization

The company is organized to plan, coordinate, and supervise the engineering support functions of the battalion. It is structured to facilitate task organization for operations conducted by the battalion in support of the MEF or any combination of smaller MAGTFs. (See figure 5-24 on page 5-50.)

(1) Command and Control. The company commander directs and controls command support functions relating to operations, administration, and logistics/CSS for the company.

(2) Firepower. Organic firepower capability is limited to individual and crew-served weapons for personal and local security.

(3) Mobility. Organizational vehicles of the company provide limited mobility. Transportation support is required from the engineer support company of the engineer support battalion and/or the motor transport battalion to effect displacement.

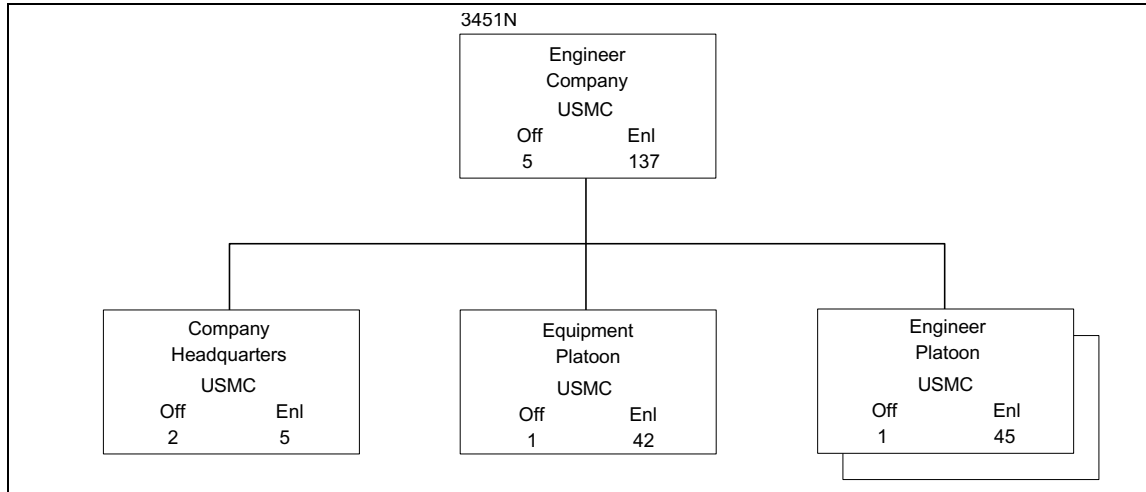

Figure 5-24. Engineer Company, Engineer Support Battalion.

(4) Communications. Communications support is provided by the H&S company of the engineer support battalion.

d. Concept of Employment

The company is the basic organization for general engineering support to a MAGTF. The company normally operates in general support of the MEF under the centralized control of the engineer support battalion. It is capable of independent operations when reinforced with equipment and personnel from the H&S, engineer support, bridge, and bulk fuel companies of the engineer support battalion and/or elements of naval construction units.

e. Administrative Capability

Administrative support is provided by the consolidated administration section of the H&S company of the engineer support battalion.

f. Logistic Capabilities

(1) Supply. Supply support is provided by the H&S company of the engineer support battalion.

(2) Maintenance. The company is capable of organizational (1st echelon) maintenance on organic equipment and organizational (2d echelon) maintenance on organic equipment, except for communications electronics, ordnance, EOD, and bulk fuel items. Organizational (2d echelon) and intermediate (3d and 4th echelon) maintenance support is provided by the engineer support company of the engineer support battalion and the maintenance battalion.

(3) Transportation. The company is capable of organic transportation support for command and administrative purposes.

(4) General Engineering. Engineering support, as required, is provided by appropriate companies of the engineer support battalion.

(5) Health Services. Medical support is provided by the H&S company of the engineer support battalion, and dental support is provided by the dental battalion.

(6) Services. Services support, as required, is provided by the service company of the H&S battalion.

(7) Messing. Food service support is provided by the H&S company of the engineer support battalion.

(8) Selected Items of Equipment. See table 5-20.

b. Tasks

5026. Landing Support Battalion (LSB)

a. Mission

The LSB provides general support, including support of the ship-to-shore movement during amphibious operations and of terminal operations during subsequent operations ashore, to permit required throughput of supplies, equipment, and personnel for sustainment in support of MEF operations. *(Note: The Active Duty Structure Force Review's changes that will merge LSB and motor transportation battalions were not finalized at the time of publication. This paragraph depicts the notional functions in their current organization. Upon finalization of their changes, a page change will be promulgated.)*

- w Provide centralized control and coordination of landing support and throughput capabilities, including port and terminal operations, as well as material-handling and air delivery support, in support of operations conducted by the MEF or MAGTFs smaller than a MEF.
- w Provide a nucleus from organic assets for the task organization of a landing force support party (LFSP) to provide the command and control structure to effect landing support and initial CSS for the assault echelon (AE) of the MEF in support of amphibious operations.
- w Provide port and terminal operations at ports, beaches, railheads, air heads, and cargo terminals,

TAM Number	Item	Quantity
A1260	Navigation set, AN/PSN11	4
B0171	Bucket, clamshell, HSL 100	1
B0395	Compressor, air rotary, 250 ft/min, trailer	1
B0443	Crane, high speed, high mob	1
B0475	Detecting set, mine, portable, metal, AF 108	9
B0525	Drawbar attachment, fixed rear mount, D7	2
B0565	Driver set, projectile, ramset, 4160	1
B1082	Grader, road, motorized, 130G	1
B1298	Line charge launch kit, trailer	4
B1775	Ripper attachment, three shank, rear mount, D7G	1
B1830	Saw, chain, one-man portable	4
B1922	Scraper, trailer, wheeled, 621B	1
B2462	Tractor, medium, full tracked, D7G	4
B2567	Tractor, RT, articulated steer	1
B2482	Tractor, all-wheel drive	1
B2685	Welding machine, arc, trailer mounted, DCC-353-P	1
B2705	Winch attachment, single drum, for tractor, G-80SG	1
D0209	Power unit, front, 12 1/2 ton, MK48	2
D0235	Semitrailer, low bed, 40 ton, M870	2
D0860	Trailer, cargo, 1 1/2 ton, two wheel, M105A2	4
D0878	Trailer, powered, fifth wheel, 4 x 4, MK16, MOD O	2
D0880	Trailer, tank, water, 400 gal, 1 1/2-ton, M149A1	1
D1059	Truck, cargo, 5 ton, M923	2
D1072	Truck, dump, 5 ton, 6 x 6, M929	8
D1158	Truck, utility, 1 1/4 ton, M998	8

Table 5-20. Selected Items of Equipment for the Engineer Company.

including specialized MHE and management of freight/passenger and break bulk/container cargo throughput.

- w Provide air delivery support equipment and rigger personnel beyond organic capabilities of supported units, in support of MEF operations.
- w Perform the basic engineer tasks that are required for landing support operations, including austere site preparation, construction/removal of obstacles and barriers, and establishment of routes of egress from the beach, when properly augmented.
- w Provide local security for numbered/colored beaches as required.

c. Concept of Organization

The battalion is organized to provide landing support and throughput support for amphibious operations conducted by the MEF during amphibious assaults and subsequent operations ashore. (See figure 5-25.)

(1) Command and Control. The battalion commander exercises command and control of the battalion through the battalion staff and the company commanders. He directs and controls command support functions relating to operations, administration, and logistics/CSS for the battalion.

(2) Firepower. Organic firepower capability is limited to individual and crew-served weapons for personal and local security.

(3) Mobility. The battalion is capable of displacement by organic assets.

(4) Communications. The battalion is capable of organic communications support for assigned units.

(5) Intelligence. Intelligence support, as required, is provided by the H&S battalion.

(6) Security. The battalion is capable of limited local and convoy security.

d. Concept of Employment

The battalion is organized to plan, coordinate, and supervise the landing support and throughput functions of the battalion in support of the MEF. The LSB provides the initial source for centralized CSS and logistics support management for the MEF during amphibious operations. It is structured to facilitate task organization for operations conducted by the battalion in support of the MEF or any combination of smaller MAGTFs.

e. Administrative Capability

The LSB is capable of self administration.

f. Logistic Capabilities

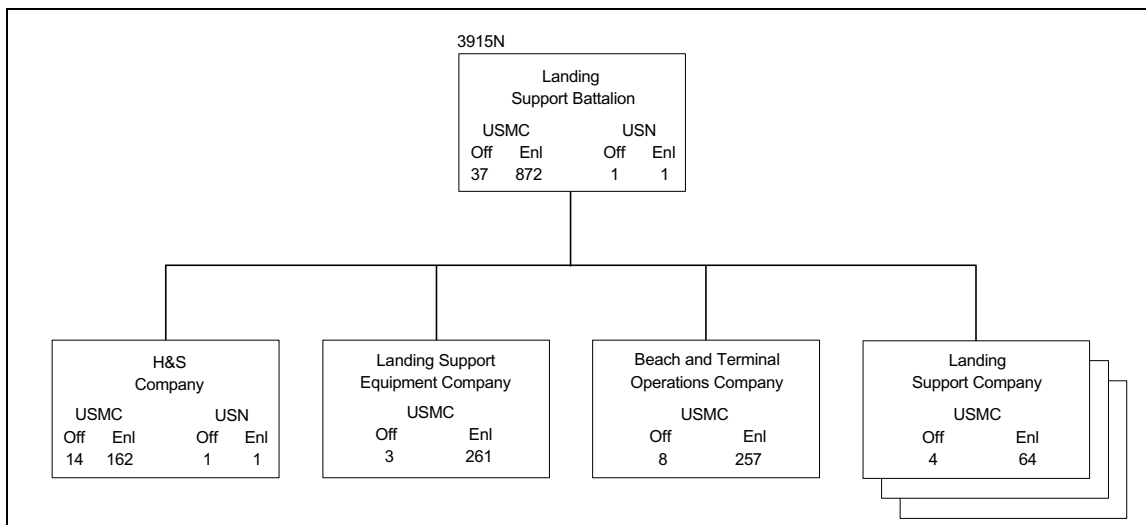

Figure 5-25. LSB.

(1) Supply. The LSB is capable of organic supply support.

(2) Maintenance. The LSB is capable of organizational (1st and 2d echelon) maintenance on organic equipment, intermediate (3d echelon) maintenance on motor transport and engineer equipment, and full maintenance (1st through 4th echelon) on organic air delivery equipment. Intermediate (3d and 4th echelon) maintenance support for organic equipment, except for air delivery equipment, is provided by the maintenance battalion.

(3) Transportation. The LSB is capable of organic transportation support for command and administrative purposes.

(4) General Engineering. The LSB is capable of limited organic engineering support. Augmentation by the engineer support battalion is required to provide full landing support and throughput capabilities in support of MAGTF operations.

(5) Health Services. Medical support is provided by H&S battalion, and dental support is provided by the dental battalion.

(6) Services. Services support, as required, is provided by the service company of the H&S battalion.

(7) Messing. The LSB is capable of organic food service support.

5027. Headquarters and Service Company, Landing Support Battalion

a. Mission

The H&S company of the LSB provides command and control, administration, and command support functions for the LSB in support of MEF operations.

b. Tasks

w Provide command support functions, including internal communications support for the battalion and separate detachments, as well as supply, ordnance, and food service support, for the battalion.

w Provide security support for the battalion.

c. Concept of Organization

The company is organized to plan, coordinate, and supervise the command support functions for the battalion. It is structured to facilitate task organization for landing support and throughput operations conducted by the battalion in support of MAGTF operations. (See figure 5-26.)

(1) Command and Control. The company commander directs and controls command support functions relating to operations, administration, and logistics/CSS for the company.

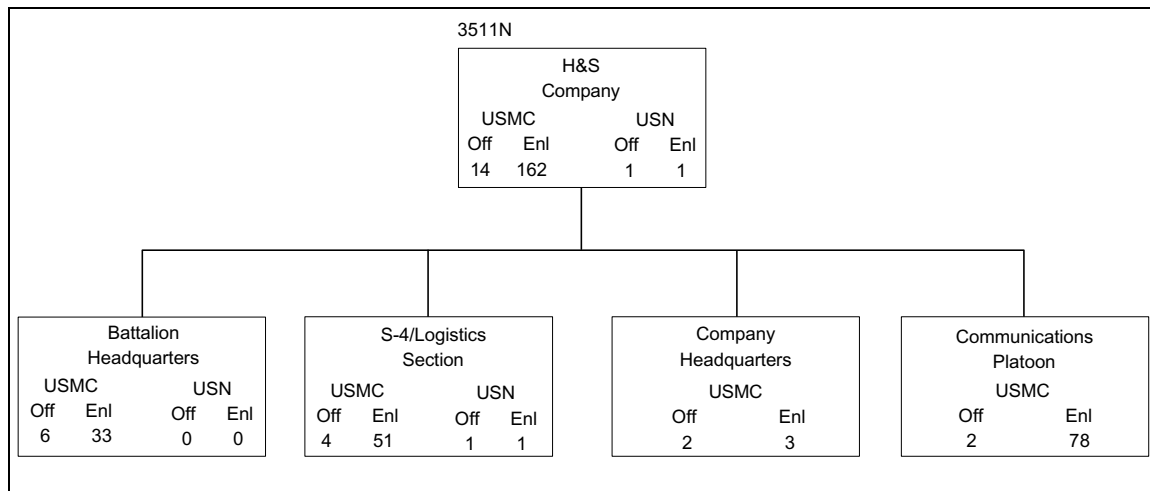

Figure 5-26. H&S Company, LSB.

(2) Firepower. Organic firepower capability is limited to individual and crew-served weapons for personal and local security.

(3) Mobility. The company is capable of displacement by organic assets.

(4) Communications. The company is capable of organic communications support for the battalion and for detachments in support of isolated units.

d. Concept of Employment

The company provides the necessary command, control, and command support functions for the coordination of landing support and throughput operations conducted by the battalion. The battalion headquarters conducts operational planning and exercises command and control of the LFSP in support of MEF operations.

e. Administrative Capability

The company is capable of self-administration and contains the consolidated administration section for the LSB.

f. Logistic Capabilities

(1) Supply. The company is capable of organic supply support.

(2) Maintenance. The company is capable of organizational (1st and 2d echelon) maintenance on ordnance and communications-electronics equipment that is organic to the battalion. Organizational (2d echelon) maintenance support for motor transport and engineer equipment is provided by the landing support equipment company of the LSB, and intermediate (3d and 4th echelon) maintenance support is provided by the maintenance battalion.

(3) Transportation. The company is capable of organic transportation support for command and administrative purposes.

(4) General Engineering. Engineering support is provided by the landing support equipment company of the LSB and by the engineer support battalion.

(5) Health Services. Medical support is provided by H&S battalion, and dental support is provided by the dental battalion.

(6) Services. Services support, as required, is provided by the service company of the H&S battalion.

(7) Messing. The company is capable of organic food service support for the battalion.

(8) Selected Items of Equipment. See table 5-21.

5028. Landing Support Equipment Company, Landing Support Battalion

a. Mission

The landing support equipment company provides MHE and container-handling support, as well as general support, organizational maintenance support for throughput support equipment (engineer and motor transport assets) of the battalion in support of MAGTF throughput operations.

b. Tasks

- w Provide MHE support for the MEF beyond the organic capability of supported unit.
- w Provide specialized MHE and container-handling support for the management of break bulk/container throughput operations at ports, beaches, railheads, air heads, and cargo terminals.
- w Provide organizational (1st and 2d echelon) maintenance support for throughput support equipment (engineer, motor transport, and specialized container-handling equipment) that is organic to the company and to the battalion.

c. Concept of Organization

The company is organized to plan, coordinate, and supervise the command support functions for the battalion. It is structured to facilitate task organization for throughput operations conducted by the battalion in support of MAGTF operations. (See figure 5-27.)

(1) Command and Control. The company commander directs and controls command support functions relating to operations, administration, and logistics/CSS for the company.

TAM Number	Item	Quantity
A0662	FMF end-user computer equipment	5
A1220	Heliport lighting set	12
A1816	Radio set, AN/GRC-210A	2
A1935	Radio set, ANIMRC 138A	3
A1957	Radio set, AN/MRC145	4
A2073	Radio set, AN/PRC-119D	10
A2065	Radio set, AN/PRC104	11
A2069	Radio set, AN/PRC113	4
A2070	Radio set, PRC119	40
A2167	Radio set, AN/VRC-88A	4
A2635	Telephone set, TA838A	48
B1645	Refrigeration unit, 100 ft ³	1
B1710	Refrigerator, rigid box 350	1
D0850	Trlr, 3/4 T, M101A3	2
D1158	Trk, util, M998	9
E0989	Machine gun, 7.62 mm, M240G	2
E0994	Machine gun, 40 mm, MK19	2

Table 5-21. Selected Items of Equipment for the H&S Company of the LSB.

(2) Firepower. Organic firepower capability is limited to individual and crew-served weapons for personal and local security.

(3) Mobility. Organizational vehicles of the company provide limited mobility. Heavy motor transport support is

required from the motor transport battalion to effect displacement.

(4) Communications. Communications support is provided by the H&S company of the LSB.

d. Concept of Employment

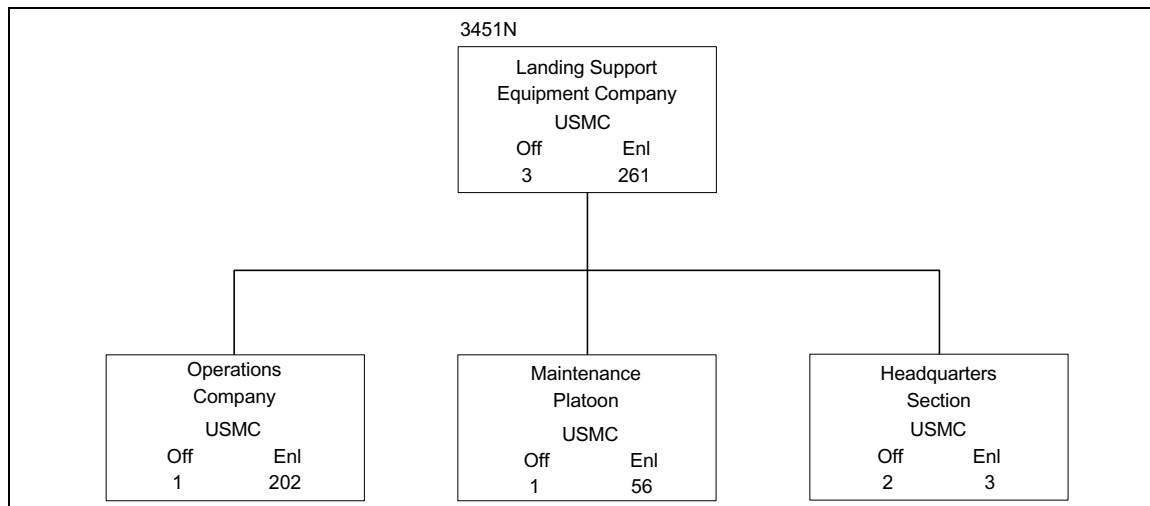

Figure 5-27. Landing Support Equipment Company, LSB.

The company provides centralized, general support landing and maintenance support to facilitate and expedite throughput operations in support of MAGTF operations. It is equipped with tactical engineering cranes, buckets, graders, forklifts, and light sets to facilitate throughput operations. The company can be task organized to provide landing support equipment to a MEF, two BSSGs, or smaller CSSEs.

e. Administrative Capability

Administrative support is provided by the consolidated administration section of the H&S company of the LSB.

f. Logistic Capabilities

(1) Supply. Supply support is provided by the H&S company of the LSB.

(2) Maintenance. The company is capable of organizational (1st and 2d echelon) maintenance on organic landing support equipment and intermediate (3d echelon) maintenance on engineer and motor transport assets organic to the LSB. Intermediate (3d and 4th echelon) maintenance support is provided by the maintenance battalion.

(3) Transportation. The company is capable of organic transportation support for command and administrative purposes.

(4) General Engineering. The company is capable of limited organic engineering support. Engineering support, as required, is provided by the engineer support battalion.

(5) Health Services. Medical support is provided by H&S battalion, and dental support is provided by the dental battalion.

(6) Services. Services support, as required, is provided by the service company of the H&S battalion.

(7) Messing. Food service support is provided by the H&S company of the LSB.

(8) Selected Items of Equipment. See table 5-22.

5029. Beach and Terminal Operations Company, Landing Support Battalion

a. Mission

The beach and terminal operations company provides general support transportation support in coordinating throughput operations of the MEF.

b. Tasks

- w Provide personnel and equipment for the loading, unloading, and movement of supplies at designated ports, beaches, railheads, air heads, and cargo terminals and in dumps or depots.
- w Develop and maintain skills in throughput management operations.
- w Provide air delivery support to the MEF and other services, as required.
- w Provide transportation management services, as required, to the MEF.

c. Concept of Organization

The company is organized to facilitate throughput operations in support of MAGTF operations. It provides management and operation of ports, air heads, railheads, and other cargo/passenger terminal operations, as well as air delivery support, as required. (See figure 5-28.)

(1) Command and Control. The company commander directs and controls command support functions relating to operations, administration, and logistics/CSS for the company.

(2) Firepower. Organic firepower capability is limited to individual and crew-served weapons for personal and local security.

(3) Mobility. Organizational vehicles of the company provide limited mobility. Transportation support is required from battalion assets and motor transport battalion augmentation.

(4) Communications. Communications support is provided by the H&S company of the LSB.

d. Concept of Employment

When directed, the company assumes responsibility for throughput operations after control of beaches/ports has been passed to the FSSG. It provides air delivery support

TAM Number	Item	Quantity
B0446	Crane, RT, hydraulic, light	6
B0391	Container handler, RT	11
B0443	Crane, high speed, high mob	18
B1082	Grader, road, motorized	3
B2460	Tractor, full tracked, blade, 1150E	6
B2462	Tractor, medium, full tracked, D7G	6
B2464	Tractor, full tracked, w/blade MC1150E	4
B2561	Truck, forklift, extendable boom, 10,000-lb capacity	47
B2566	Truck, forklift, MC4000	30
B2567	Tractor, RT, articulated steer	30
D0880	Trailer, tank, water, 400 gal, M149	9
D1002	Truck, ambulance, M1035	3
D1059	Truck, cargo, 5 ton, 6 x 6, M923	11
D1072	Truck, dump, M929	3
D1158	Truck, utility, cargo/troop, M998	5
D1212	Truck, wrecker, 5 ton, M936	1
E0980	Machine gun, .50 cal, M2	3
E0989	Machine gun, 7.62 mm, M240G	2
E0994	Machine gun, 40 mm, MK19	2

Table 5-22. Selected Items of Equipment for the Landing Support Equipment Company.

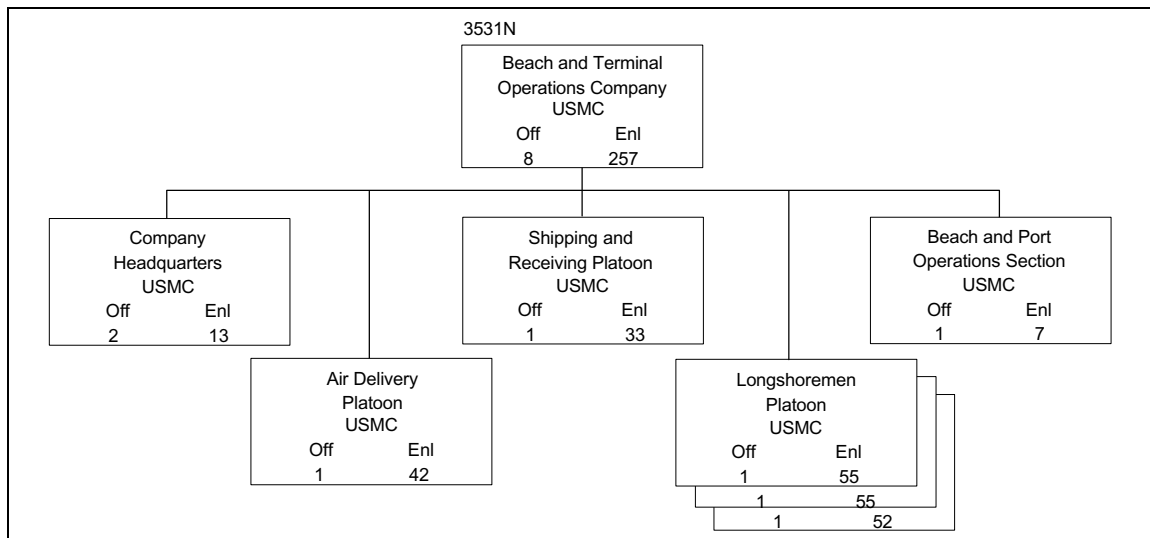

Figure 5-28. Beach and Terminal Operations Company.

and, when augmented by other elements of the FSSG, controls air terminals in support of MEF operations, including conducting departure airfield control group (DACG)/arrival airfield control group operations.

e. Administrative Capability

Administrative support is provided by the consolidated administration section of the H&S company of the LSB.

f. Logistic Capabilities

(1) Supply. Supply support is provided by the H&S company of the LSB.

(2) Maintenance. The company is capable of organizational (1st echelon) maintenance on organic equipment and organizational/intermediate (2d through 4th echelon) maintenance on organic air delivery equipment. Organizational (2d echelon) and intermediate (3d and 4th echelon) maintenance support for other organic equipment is provided by the H&S company of the LSB, the landing support equipment companies of the LSB, and the maintenance battalion.

(3) Transportation. The company is capable of organic transportation support for command and administrative purposes.

(4) General Engineering. Engineering support, as required, is provided by the landing support equipment company and the engineer support battalion.

(5) Health Services. Medical support is provided by H&S battalion, and dental support is provided by the dental battalion.

(6) Services. Services support, as required, is provided by the service company of the H&S battalion.

(7) Messing. Food service support is provided by the H&S company of the LSB.

(8) Selected Items of Equipment. See table 5-23.

5030. Landing Support Company, Landing Support Battalion

a. Mission

The landing support company provides command and control for throughput operations in support of surface and/or helicopter assault operations conducted by the MEF.

b. Tasks

- w Provide shore party and/or helicopter support teams, as required, in support of assault and sustained operations conducted by MAGTFs.
- w Prepare, mark, and control landing beaches or zones as required.
- w Establish temporary multiclass supply storage sites ashore for the sustainment of the MAGTF.
- w Coordinate unloading of supplies from landing craft, ships, and helicopters in support of MEF operations, when properly reinforced.
- w Coordinate transportation support for the evacuation of casualties and EPWs. Augmentation by medical personnel from the medical battalion is required.
- w Provide DACGs/arrival airfield control groups to facilitate the control and coordination of loading and

TAM Number	Item	Quantity
B2035	Sling, helo, 40K lbs	155
C4070	Bag, cargo, aerial delivery	630
D1158	Trk, util, M998	5
E0980	Machine gun, cal .50, M2	2
E0994	Machine gun, 40 mm, MK19	2

Table 5-23. Selected Items of Equipment for the Beach and Terminal Operations Company.

unloading of units deploying or redeploying by fixed-wing aircraft.

c. Concept of Organization

The company is organized to provide the nucleus of personnel and equipment that are required to task organize an LFSP, composed of MAGTF and naval units, for the initial logistics/CSS of the MEF in amphibious and helicopterborne operations. (See figure 5-29.)

(1) Command and Control. The company commander directs and controls command support functions relating to operations, administration, and logistics/CSS for the company.

(2) Firepower. Organic firepower capability is limited to individual and crew-served weapons for personal and local security.

(3) Mobility. Organizational vehicles of the company provide limited mobility. Transportation support is required to effect displacement.

(4) Communications. Communications support is provided by the H&S company of the LSB.

d. Concept of Employment

The company provides landing and throughput support to the MEF and MAGTFs smaller than a MEF in support of amphibious and helicopterborne operations that require substantial logistic support in excess of supported units' organic capabilities. The companies are reinforced with assets from the beach and terminal operations company and/or landing support equipment company when special equipment support is required. When augmented by elements of the naval beach group, it provides the nucleus for the LFSP, which provides coordination of initial throughput and sustainment support for the MEF, under the operational control (OPCON) of the MEF commander, in support of amphibious operations and subsequent operations ashore. Upon establishment ashore of the CSSE, OPCON of the LFSP passes to the CSSE commander for continuation of landing support as required. The company is capable of coordinating the defense of a colored beach.

e. Administrative Capability

Administrative support is provided by the consolidated administration section of the H&S company of the LSB.

f. Logistic Capabilities

(1) Supply. Supply support is provided by the H&S company of the LSB.

(2) Maintenance. The company is capable of organizational (1st echelon) maintenance on organic equipment.

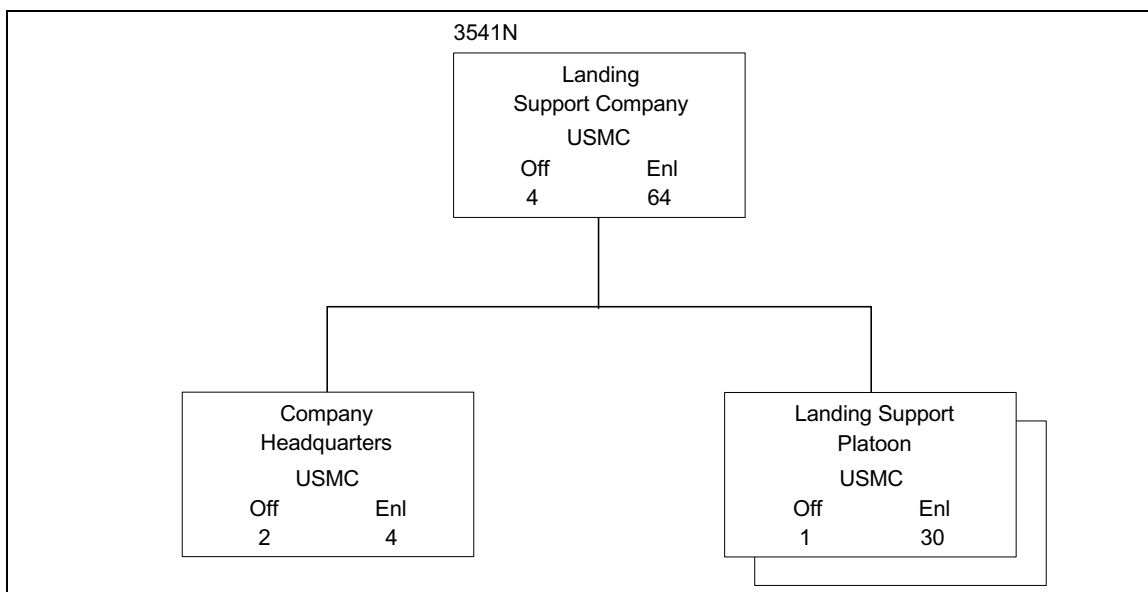

Figure 5-29. Landing Support Company, LSB.

Organizational (2d echelon) maintenance support is provided by the H&S company of the LSB. Intermediate (3d and 4th echelon) maintenance support is provided by the maintenance battalion.

(3) Transportation. The company is capable of organic transportation support for command and administrative purposes.

(4) General Engineering. Engineering support, as required, is provided by the engineer support battalion.

(5) Health Services. Medical support is provided by H&S battalion, and dental support is provided by the dental battalion.

(6) Services. Services support, as required, is provided by the service company of the H&S battalion.

(7) Messing. Food service support is provided by the H&S company of the LSB.

(8) Selected Items of Equipment. See table 5-24.

5031. Motor Transport Battalion

a. Mission

The motor transport battalion provides direct and general support, medium-lift and heavy-lift transportation support for the MAGTF, including motor transport support to the FSSG for its support mission.

b. Tasks

- w Provide medium- and heavy-lift transport and distribution of bulk dry/water cargo, class III and III(A), and class V and V(A) supplies.
- w Provide line haul and unit/supply point distribution of bulk liquids, with motor transport augmentation as required from supported unit(s).
- w Provide heavy equipment lift augmentation, including evacuation of tracked vehicles, to supported units of the MEF.
- w Provide personnel lift augmentation to supported units of the MEF.

c. Concept of Organization

The battalion consists of a H&S company, a general support motor transport company, and two direct support motor transport companies. (See figure 5-30.) The battalion is equipped and organized to provide logistic and tactical cargo vehicle support and petroleum transporter support. *(Note: The Active Duty Structure Force Review's changes that will merge LSB and motor transportation battalions were not finalized at the time of publication. This paragraph depicts the notional functions in their current organization. Upon finalization of their changes, a page change will be promulgated.)*

(1) Command and Control. The battalion commander exercises command and control of the battalion through the battalion staff and company commanders. He directs and controls command support functions relating to operations, administration, and logistics/CSS for the battalion.

TAM Number	Item	Quantity
B2035	Sling, helo, 40K	20
B1830	Saw, chain, one-man portable	2
B2030	Sling, helicopter, 15K	152
D1158	Truck, utility, M998	3
E0989	Machine gun, M240G	2
E0994	Machine gun, 40 mm, MK19	2

Table 5-24. Selected Items of Equipment for

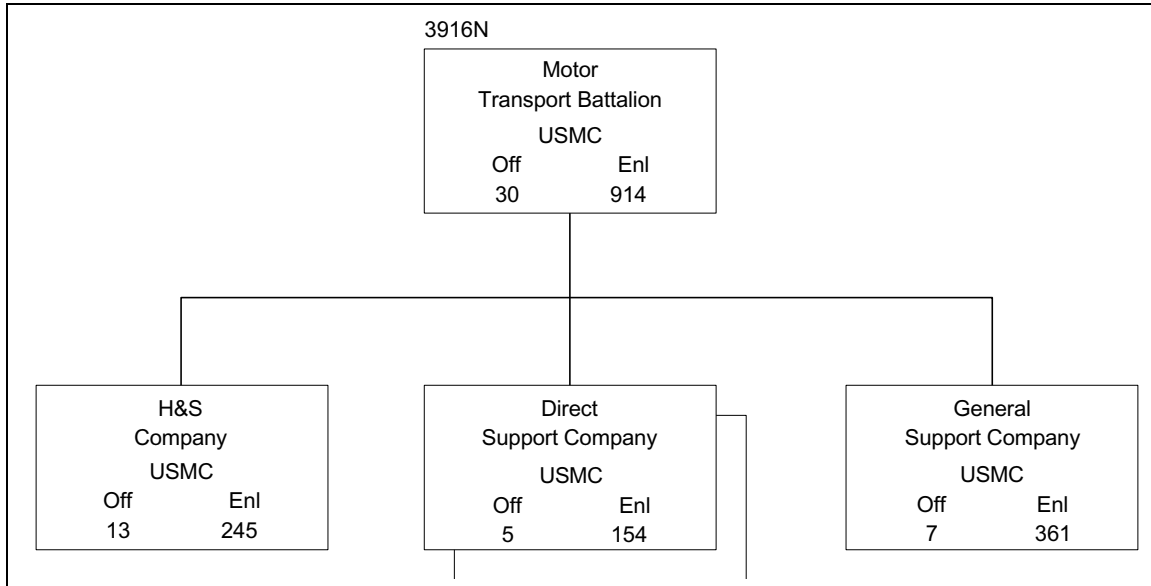

Figure 5-30. Motor Transport Battalion.

(2) Firepower. Organic firepower capability is limited to individual and crew-served weapons for personal, local, and convoy security.

(3) Mobility. The battalion is capable of displacement by using organic assets.

(4) Communications. The battalion is capable of providing organic communications support for assigned units. Augmentation, as required, is provided by the communications company of the H&S battalion.

(5) Intelligence. Intelligence support, as required, is provided by the H&S battalion.

(6) Security. The battalion is capable of limited local and convoy security.

d. Concept of Employment

The battalion is structured and equipped to provide tactical medium and heavy, cargo-type transportation support to the MEF. Direct support motor transport companies, normally deployed with the AE, contain a cross-section of medium- and heavy-vehicle assets to support the MEF. The general support motor transport company, normally deployed with the assault follow-on echelon (AFOE), augments the direct support motor transport companies in sustained operations.

e. Administrative Capability

The battalion is capable of self administration.

f. Logistic Capabilities

(1) Supply. The battalion is capable of organic supply support.

(2) Maintenance. The battalion is capable of organizational (1st and 2d echelon) maintenance on organic motor transport, engineering, communications electronics, and ordnance equipment. Intermediate (3d and 4th echelon) maintenance support is provided by the maintenance battalion.

(3) Transportation. The battalion is capable of organic transportation support for command and administrative purposes, and for tactical medium and heavy cargo-type lifts in support of the MEF.

(4) General Engineering. Engineering support, as required, is provided by the engineer support battalion.

(5) Health Services. Medical support is provided by H&S battalion, and dental support is provided by the dental battalion.

(6) Services. Services support, as required, is provided by the service company of the H&S battalion.

(7) Messing. Food service support is provided by the H&S battalion.

5032. Headquarters and Service Company, Motor Transport Battalion

a. Mission

The H&S company of the motor transport battalion provides command, control, administration, and command support functions for the battalion.

b. Tasks

- w Provide command support functions for the battalion, including administration, communications, and supply support.
- w Provide organizational (1st and 2d echelon) maintenance for motor transport, engineering, communications-electronics, and ordnance equipment that is organic to the battalion.
- w Provide local security for the battalion, within capability.

c. Concept of Organization

The company is organized to provide the motor transport battalion with command and control, organic communications, and organizational (2d echelon) maintenance support. Intermediate maintenance (3d and 4th echelon) is performed by the maintenance battalion. (See figure 5-31.)

(1) Command and Control. The company commander directs and controls command support functions relating to operations, administration, and logistics/CSS for the company.

(2) Firepower. Organic firepower capability is limited to individual and crew-served weapons for personal and local security.

(3) Mobility. The company is capable of displacement by using organic assets.

(4) Communications. The company is capable of organic communications support for the battalion. Additional support, as required, is provided by the communications company of the H&S battalion.

d. Concept of Employment

The company serves as the CE for the battalion. It provides essential command support functions to the battalion, includ-

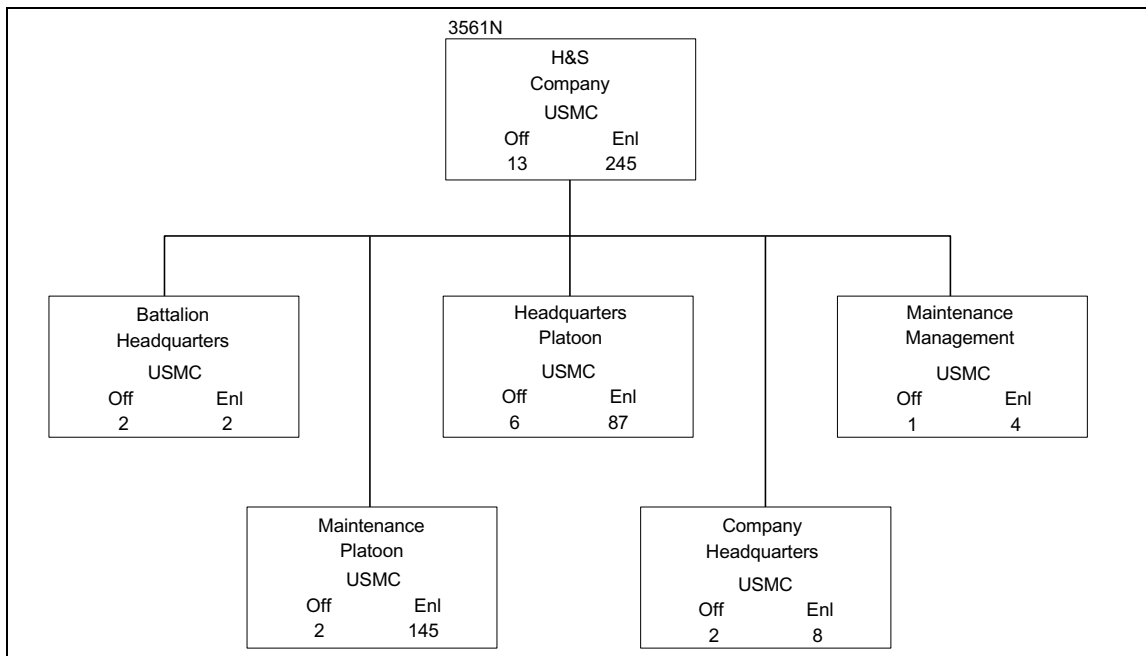

Figure 5-31. H&S Company, Motor Transport Battalion.

ing centralized and/or decentralized communications and organizational (1st and 2d echelon) maintenance support.

e. Administrative Capability

The company is capable of self-administration and contains the consolidated administration section for the motor transport battalion.

f. Logistic Capabilities

(1) Supply. The company is capable of organic supply support.

(2) Maintenance. The company is capable of organizational (1st and 2d echelon) maintenance on motor transport, engineering, communications-electronics, and ordnance equipment that is organic to the battalion. Intermediate (3d and 4th echelon) maintenance support is provided by the maintenance battalion.

(3) Transportation. The company is capable of organic transportation support for command and administrative purposes.

(4) General Engineering. Engineering support, as required, is provided by the engineer support battalion.

(5) Health Services. Medical support is provided by H&S battalion, and dental support is provided by the dental battalion.

(6) Services. Services support, as required, is provided by the service company of the H&S battalion.

(7) Messing. Food service support is provided by the H&S battalion.

(8) Selected Items of Equipment. See table 5-25 on page 5-64.

5033. General Support Company, Motor Transport Battalion

a. Mission

Provide general support, medium- and heavy-lift transportation support for throughput and sustainment operations in support of the MAGTF.

b. Tasks

- w Provide line haul and distribution of bulk water (class I) and bulk fuel (class III and class III(A)) for the MEF.
- w Provide medium- and heavy-lift motor transport for the movement of bulk dry cargo, class V and V(A), and heavy equipment for the MEF.
- w Provide unit and supply point distribution of bulk water and fuel for the MEF as required.
- w Augment the motor transport and supply distribution capabilities of the direct support motor transport company, as required, in support of the MEF.

c. Concept of Organization

The company is organized into a company headquarters, two transportation platoons, a heavy equipment transport platoon, a bulk fuel transport platoon, and a bulk water transport platoon. It is structured to facilitate task organization for operations conducted by the battalion in support of sustained MAGTF operations. (See figure 5-32 on page 5-65.)

(1) Command and Control. The company commander directs and controls command support functions relating to operations, administration, and logistics/CSS for the company.

(2) Firepower. Organic firepower capability is limited to individual and crew-served weapons for personal, local, and convoy security.

(3) Mobility. The company is capable of displacement by using organic assets.

(4) Communications. Communications support is provided by the H&S company of the motor transport battalion.

d. Concept of Employment

The company provides medium- and heavy-lift motor transport and bulk liquid distribution support to the MEF and MAGTFs smaller than a MEF in sustained operations. The company normally deploys as part of the AFOE. It is employed in general support of the MEF to transport cargo, equipment, and personnel over extended distances for

TAM Number	Item	Quantity			Total
		H&S Company	General Support Company	Direct Support Company (Each)	
A1935	Radio set, AN/MRC-138B	4	—	—	4
A1957	Radio set, AN/MRC 145	5	—	—	5
A2065	Radio set, AN/PRC 104	3	—	—	3
A2070	Radio set, PRC 119	10	—	—	10
A2151	Radio set, vehicle (PLRS)	2	—	2	6
B0635	Floodlight set, skid mounted	2	—	—	2
B1580	Pump module, fuel	—	13	7	27
B1581	Pump module, water	—	19	4	27
B2085	Storage tank module, fuel	—	60	28	116
B2086	Storage tank module, water	—	62	22	106
D0215	Semitrailer, fueler, 5,000 gal, M970	—	20	—	20
D0235	Semitrailer, low bed, 40 ton, M870	—	13	—	13
D0876	Trailer, powered, 22 1/2 ton, container hauler, MK14	—	67	52	171
D0877	Trailer, powered, wrecker/recovery, MK15	6	—	—	6
D0878	Trailer, powered, fifth wheel, MK16	—	16	—	16
D0879	Trailer, powered, 20 ton, MK17	—	21	10	41
D0880	Trailer, tank, water 400 gal, M149A2	4	4	16	40
D0881	Trailer, ribbon bridge, MK18	16	53	6	81
D1059	Truck, cargo, 5 ton, M923	6	4	74	158
D1134	Truck, tractor, 5 ton, M931	—	20	—	20
D1158	Truck, utility, cargo/troop carrier, M998	—	21	10	41
D1212	Truck, wrecker, 5 ton, M936	7	—	—	7
E0980	Machine gun, .50 cal, M2	6	18	15	54
E0989	Machine gun, 7.62 mm, M240G	2	4	4	14
E0994	Machine gun, 40 mm, MK19	6	17	11	45

Table 5-25. Selected Items of Equipment for the H&S, General Support, and Direct Support Companies of the Motor Transport Battalion.

sustained periods of time. Organic equipment includes 5-ton tactical cargo trucks, Logistics Vehicle Systems (LVSs), and 40-ton and 70-ton semitrailers.

e. Administrative Capability

Administrative support is provided by the consolidated administration section of the H&S company of the motor transport battalion.

f. Logistic Capabilities

(1) Supply. Supply support is provided by the H&S company of the motor transport battalion.

(2) Maintenance. The company is capable of organizational (1st echelon) maintenance on all assigned equipment. Organizational (2d echelon) maintenance on assigned equipment is provided by the H&S company of the motor transport battalion. Intermediate (3d and 4th echelon) maintenance support is provided by the maintenance battalion.

(3) Transportation. The company is capable of organic transportation support for command and administrative purposes and for medium and heavy lifts in support of the MEF.

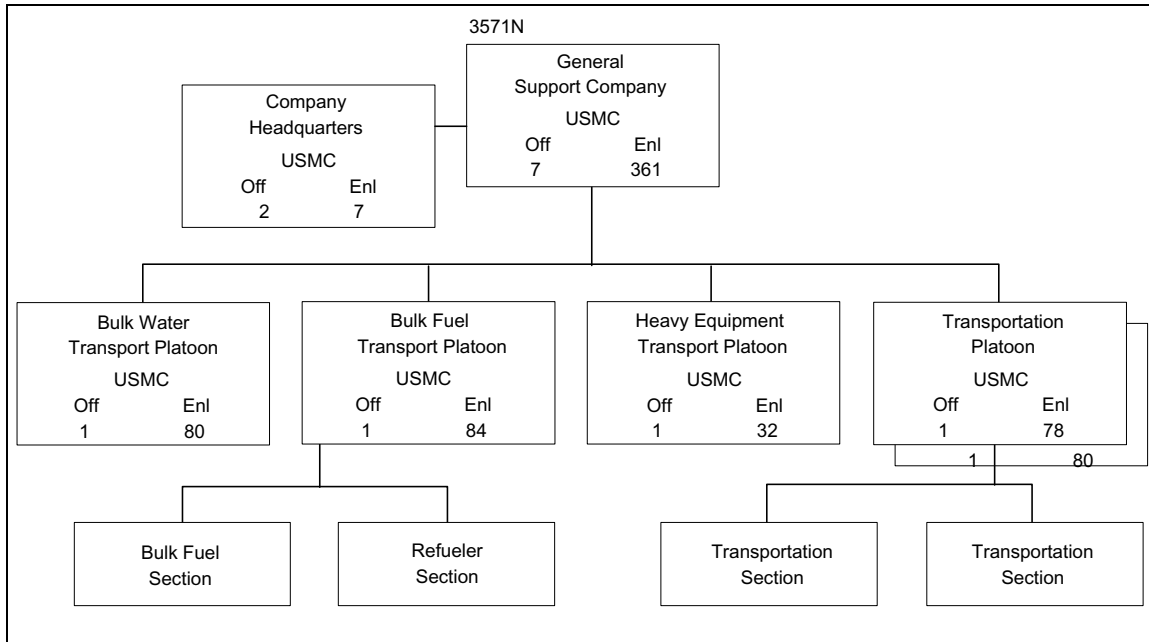

Figure 5-32. General Support Company, Motor Transport Battalion.

(4) General Engineering. Engineering support, as required, is provided by the engineer support battalion.

(5) Health Services. Medical support is provided by H&S battalion, and dental support is provided by the dental battalion.

(6) Services. Services support, as required, is provided by the service company of the H&S battalion.

(7) Messing. Food service support is provided by the H&S battalion.

(8) Selected Items of Equipment. See table 5-25.

5034. Direct Support Company, Motor Transport Battalion

a. Mission

Provide direct and general support, medium- and heavy-lift transportation support and supply support for throughput and sustainment operations of the FSSG in support of the MEF.

b. Tasks

w Provide line haul and distribution of bulk water (class I) and bulk fuel (class III and III(A)) for the FSSG.

w Provide medium- and heavy-lift motor transport for the movement of bulk dry cargo, class V and V(A), and heavy equipment in support of FSSG operations.

w Augment the personnel lift capability, as required, of elements of the MAGTF.

c. Concept of Organization

The company is organized to plan, coordinate, and supervise the command supply and transportation support functions for the company in support of the FSSG's mission. There is a company headquarters, three truck platoons, and a liquid-transport platoon. The platoons are capable of being task organized and attached to other organizations. (See figure 5-33.)

(1) Command and Control. The company commander directs and controls command support functions relating to operations, administration, and logistics/CSS for the company.

(2) Firepower. Organic firepower capability is limited to individual and crew-served weapons for personal, local, and convoy security.

(3) Mobility. The company is capable of displacement by using organic assets.

(4) Communications. Communications support is provided by the H&S company of the motor transport battalion. Augmentation, as required, is provided by the communications company of the H&S battalion.

d. Concept of Employment

The company is structured to provide sustained, direct support transportation and supply support to the CSSE (i.e., the FSSG or two MSSGs) and general support transportation and supply support to the MAGTF (i.e., a MEF or two MEUs). It transports cargo, equipment, fuel, water, and/or personnel over extended distances for sustained periods of time.

e. Administrative Capability

Administrative support is provided by the consolidated administration section of the H&S company of the motor transport battalion.

f. Logistic Capabilities

(1) Supply. Supply support is provided by the H&S company of the motor transport battalion.

(2) Maintenance. The company is capable of organizational (1st echelon) maintenance on organic equipment. Organizational (2d echelon) maintenance support for organic motor transport, engineer, and ordnance equipment is provided by the H&S company of the motor transport battalion. Intermediate (3d and 4th echelon) maintenance support is provided by the maintenance battalion.

(3) Transportation. The company is capable of organic transportation support for command and administrative purposes and for medium and heavy lifts in support of MAGTF operations.

(4) General Engineering. Engineering support, as required, is provided by the engineer support battalion.

(5) Health Services. Medical support is provided by H&S battalion, and dental support is provided by the dental battalion.

(6) Services. Services support, as required, is provided by the service company of the H&S battalion.

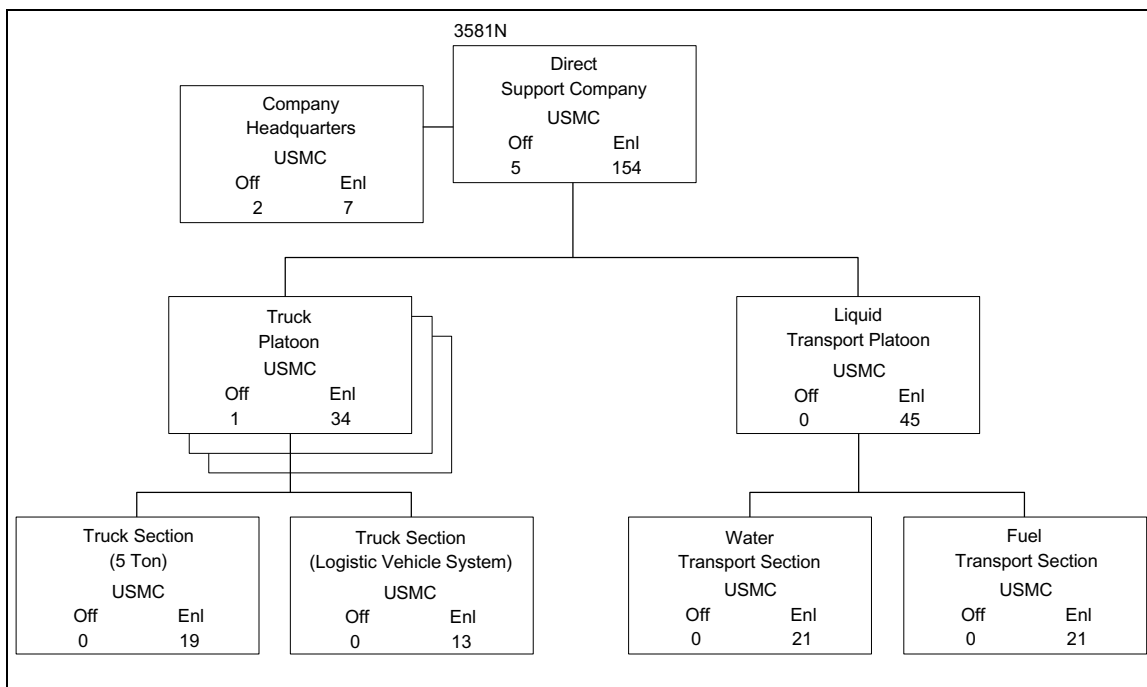

Figure 5-33. Direct Support Company, Motor Transport Battalion.

(7) Messing. Food service support is provided by the H&S battalion, the FSSG, or the support unit.

(8) Selected Items of Equipment. See table 5-25 on page 5-64.

5035. Medical Battalion

a. Mission

The medical battalion provides direct and general support medical support to the MEF.

b. Tasks

- w Provide health care through the 2d echelon of medical care, including initial resuscitative care, resuscitative surgery, and temporary hospitalization of casualties, to the MEF.
- w Provide medical regulating services for the MEF.
- w Provide preventive medicine support to the MEF.
- w Assist in the collection, analysis, and dissemination of medical intelligence.
- w Provide the medical elements for the establishment of casualty decontamination and treatment stations.
- w Provide medical support for management of mass casualties and combat stress casualties.

c. Concept of Organization

The medical battalion is organized to plan, coordinate, and supervise the medical support functions of the MEF. It is structured to facilitate task organization for operations conducted by the battalion in support of the MEF or any combination of smaller MAGTFs operating in widely separated geographical areas. (See figure 5-34.)

(1) Command and Control. The battalion commander exercises command and control of the battalion through the battalion staff and the company commanders. He directs and controls command support functions relating to operations, administration, and logistics/CSS for the battalion.

(2) Firepower. Organic firepower capability is limited to individual and crew-served weapons for personal security and for defense of medical installations in accordance with applicable international law.

(3) Mobility. Organizational vehicles of the battalion, transportable by fixed-wing aircraft and by heavy-lift rotary-wing aircraft, provide limited mobility. Transportation support is required from the motor transport battalion to effect displacement.

(4) Communications. The battalion is capable of organic single-channel communications support. Communications support, as required, is provided by the communications company of the H&S battalion.

(5) Intelligence. Intelligence support, as required, is provided by the H&S battalion.

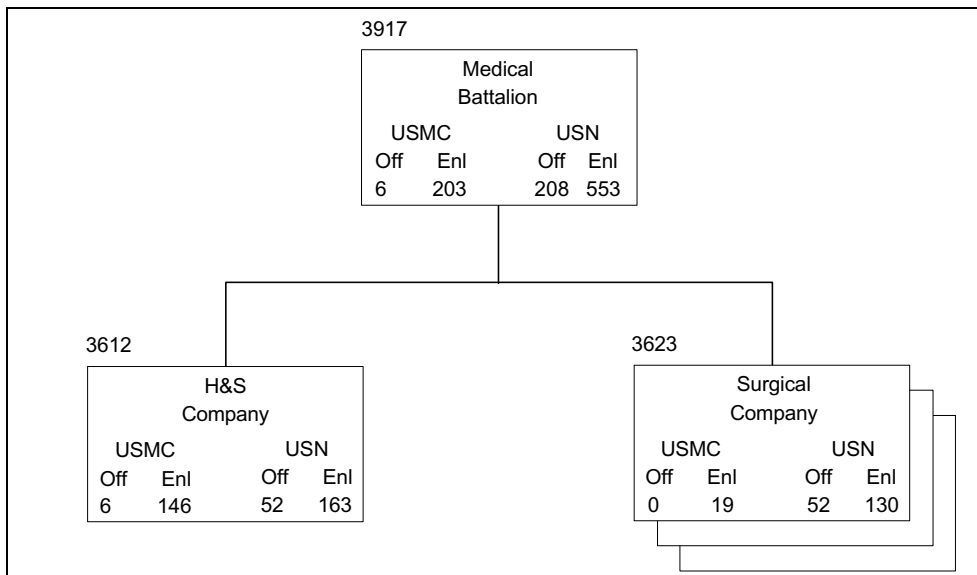

Figure 5-34. Medical Battalion.

(6) Security. The battalion has a limited organic security capability. Security support, as required, is provided by the H&S battalion.

d. Concept of Employment

The battalion units are task organized to support the mobility and flexibility requirements of the MAGTFs. The medical battalion constitutes appropriately sized and configured medical treatment facilities in support of specific MAGTFs.

(1) Shock-Trauma Platoons, H&S Company.

The shock-trauma platoons are the most mobile of the medical battalion units. They are designed to provide direct support to medical elements organic to the GCE and ACE of a MAGTF. Where required by the operational plan, shock-trauma platoons lend themselves to being task organized for support of MEU- and MEF(FWD)-sized MAGTFs. They may be combined or collocated to increase their own capabilities and the care provided to Marines or to relieve a battalion aid station (BAS) of its patients, thereby allowing the BAS to follow in trace of its CE or act as the advance element for the location of a surgical company. One way in which a shock-trauma platoon may be employed is as part of a mobile CSSD.

(2) Surgical Company. By virtue of its larger size, a fully deployed surgical company is best suited for a general support role from a location less likely to require displacement and relocation. However, the surgical company structure and organization lends itself to dividing into independent elements for deployment and therefore can also be used to provide direct support to operating forces through the use of shock-trauma platoons. For example, the triage/evacuation platoon of a company may be deployed with the AE of a combat force, while the holding and surgical platoons are placed in the AFOE. Once ashore, the remaining units of the surgical company may join the triage/evacuation platoon, or the company may establish itself in a different location.

(3) Levels of Patient Care. Shock-trauma platoons provide echelon I-level care, and the surgical company provides echelon II-level care. Shock-trauma platoons provide the emergency stabilization care required for evacuation. The capabilities of the surgical company are built around the surgeons contained in its T/O. If tactical situations dictate, a shock-trauma platoon could be augmented with a section from the surgical company to provide a forward surgical capability.

e. Administrative Capability

The medical battalion is capable of self-administration for assigned Marine Corps personnel. Administrative support for assigned U.S. Navy personnel is provided by the service company of the H&S battalion.

f. Logistic Capabilities

(1) Supply. The battalion is capable of organic supply support. The medical logistics company of the supply battalion provides class VIII supply support.

(2) Maintenance. The battalion is capable of organizational (1st echelon) maintenance on organic equipment and organizational (2d echelon) maintenance on organic equipment, except for medical equipment. The medical logistics company of the supply battalion provides organizational (2d echelon) and intermediate (3d and 4th echelon) maintenance support for medical equipment and maintains the AMALs. Intermediate (3d and 4th echelon) maintenance support for nonmedical equipment is provided by the maintenance battalion.

(3) Transportation. The battalion is capable of organic transportation for command and administrative purposes and for evacuation of casualties from forward areas and transfer of patients to medical treatment facilities in rear areas.

(4) General Engineering. Engineering support, as required, is provided by the engineer support battalion.

(5) Health Services. The battalion is capable of organic medical support. Routine sick-call support is provided by the group aid station of the H&S battalion, and dental support is provided by the dental battalion.

(6) Services. Services support, as required, is provided by the service company of the H&S battalion.

(7) Messing. The battalion is capable of organic food service support. When collocated with the dental battalion, the medical battalion provides consolidated food service support for both battalions.

5036. Headquarters and Service Company, Medical Battalion

a. Mission

The H&S company provides command, control, and command support functions for the medical battalion.

b. Tasks

- w Provide administrative, organic supply, light motor transportation, and maintenance support to the battalion.
- w Provide limited medical evacuation for the battalion.
- w Provide medical data coordination for the battalion.
- w Provide medical department personnel, as required, to the headquarters elements of CSSDs .

c. Concept of Organization

The company is organized to plan, coordinate, and supervise the command support functions for the battalion. It is structured to facilitate task organization for operations conducted by the battalion in support of MAGTF operations. (See figure 5-35 on page 5-70.)

(1) Command and Control. The company commander directs and controls command support functions relating to operations, administration, and logistics/CSS for the company.

(2) Firepower. Organic firepower capability is limited to individual and crew-served weapons for personal security and defense of the medical installations in accordance with applicable international law, which defines company personnel as *personnel employed in the administration of medical treatment facilities*. Marine Corps personnel assigned to this company are classified as noncombatants under the provisions of international law.

(3) Mobility. Organizational vehicles of the company are helicopter transportable and provide limited mobility. Transportation support is required from the motor transport battalion to effect displacement.

(4) Communications. The company is capable of internal, single-channel communications. Communications support, as required, is provided by the communications company of the H&S battalion.

d. Concept of Employment

The company may be employed in a single CSSA or in two separate CSSAs to provide command and control facilities and administrative support for the battalion. Detachments from the service platoon, the surgical specialist section, and the communications section may be assigned to augment subordinate companies.

e. Administrative Capabilities

The company is capable of self-administration for assigned Marine Corps personnel. Administrative support for assigned Navy personnel is provided by the service company of the H&S battalion.

f. Logistic Capabilities

(1) Supply. The company is capable of organic supply support. The medical logistics company of the supply battalion provides class VIII supply support as required.

(2) Maintenance. The company is capable of organizational (1st and 2d echelon) maintenance on organic equipment. Intermediate (3d and 4th echelon) maintenance support for nonmedical equipment, as required, is provided by the maintenance battalion and for medical equipment, is provided by the medical logistics company of the supply battalion.

(3) Transportation. The company is capable of organic transportation support for command and administrative purposes.

(4) General Engineering. Engineering support, as required, is provided by the engineer support battalion.

(5) Health Services. Medical support is provided by H&S battalion, and dental support is provided by the dental battalion.

(6) Services. Services support, as required, is provided by the service company of the H&S battalion.

(7) Messing. The company is capable of organic food service support and, as required, providing food service support to the dental battalion.

(8) Selected Items of Equipment. See table 5-26.

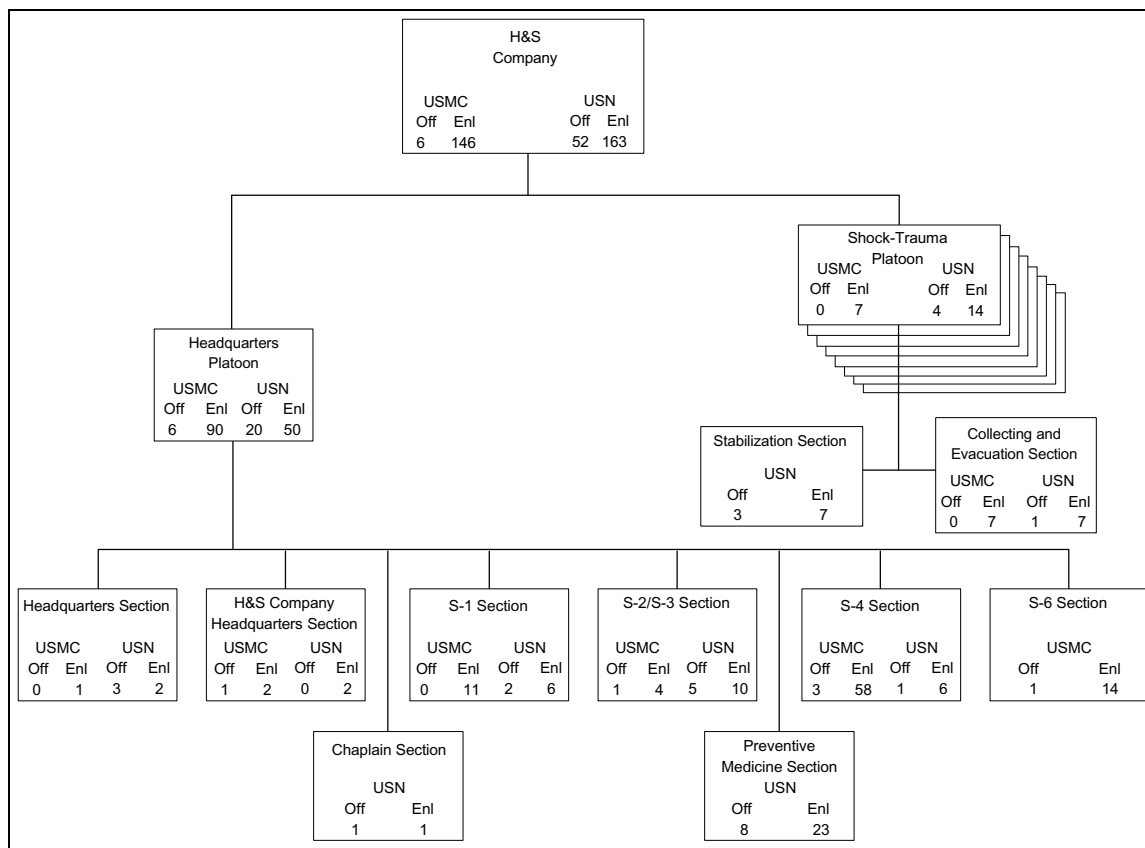

Figure 5-35. H&S Company, Medical Battalion.

5037. Surgical Support Company, Medical Battalion

a. Mission

The company provides general medical support to the MEF, including medical treatment facilities for medical and surgical care and temporary casualty holding.

b. Tasks

- w Establish medical treatment facilities for resuscitative surgery, medical treatment, and temporary hospitalization of casualties.
- w Be prepared to receive casualties from the next forward medical treatment echelon in the evacuation chain.
- w Establish medical treatment facilities for resuscitative surgery, medical treatment, and temporary holding of casualties from supported forces.

w Prepare for evacuation casualties whose medical requirements exceed the established theater evacuation policy.

w Provide and coordinate medical evacuation for the landing force.

w Provide medical support to personnel of other Services and nations as provided in applicable regulations and agreements, and provide humanitarian care as required by international law.

c. Concept of Organization

The company is organized to plan, coordinate, and supervise assigned functions of medical support for the battalion. It is structured to facilitate task organization for operations conducted by the battalion in support of the MEF, the MEF(FWD), or any combination of smaller MAGTFs. The company consists of a headquarters platoon, a triage/evacuation platoon, a surgical platoon, a holding platoon, a combat stress platoon, and an ancillary service

TAM Number	Item	Quantity
A1935	Radio set, AN/MRC-138	2
A2065	Radio set, AN/PR-104	8
A2070	Radio set, AN/PR-119	7
A2167	Radio set, AN/VRC-88A	6
A2480	Switchboard, telephone, S8-22A/PT	10
B1180	Ice making machine, flake	1
B1291	Decontamination system, MK1731	2
B1645	Refrigeration unit	3
B1710	Refrigerator, 350 cu ft	3
D0860	Trailer, cargo, M105A2	5
D0880	Trailer, tank, water, 400 gal, M149A2	2
D1001	Truck, ambul, M997	16
D1059	Truck, cargo, 5T	6
D1158	Truck, util, M998	14

Table 5-26. Selected Items of Equipment for the H&S Company

platoon. The surgical platoon consists of three surgical sections that support one operating room for 24-hour operations. The holding platoon contains three ward sections, each containing 20 medical/surgical beds. The ancillary services platoon contains two laboratory sections, two pharmacy sections and two X-ray sections. (See figure 5-36 on page 5-72.) Dental support is provided by an attached dental section.

(1) Command and Control. The company commander directs and controls command support functions relating to operations, administration, and logistics/CSS for the company.

(2) Firepower. Organic firepower capability is limited to individual and crew-served weapons for personal security and defense of the medical installations in accordance with applicable international law.

(3) Mobility. Organizational vehicles of the company are helicopter transportable and provide limited mobility. Transportation support is required from the motor transport battalion to effect displacement.

(4) Communications. The company is capable of single-channel communications. Communications support, as required, is provided by the H&S battalion.

d. Concept of Employment

An entire surgical company is structured to facilitate task organization for operations conducted by the battalion in support of the MEF(FWD), MEF, or any combination of larger MAGTFs. The surgical company is designed to allow a high degree of mobility and flexibility in deployment. A surgical company may be divided into smaller elements (sections) to task organize the support. This facilitates deploying a platoon or section in the AE and the remaining capability in the AFOE shipping. In a displacement and relocation evolution, it may be expedient to move platoons and sections in a leapfrog fashion to provide maximum continuity of patient care. A surgical section may augment the medical facility of an MWSS, bringing surgical capability to that facility. It is also suited for augmenting a shock-trauma platoon when operational conditions permit.

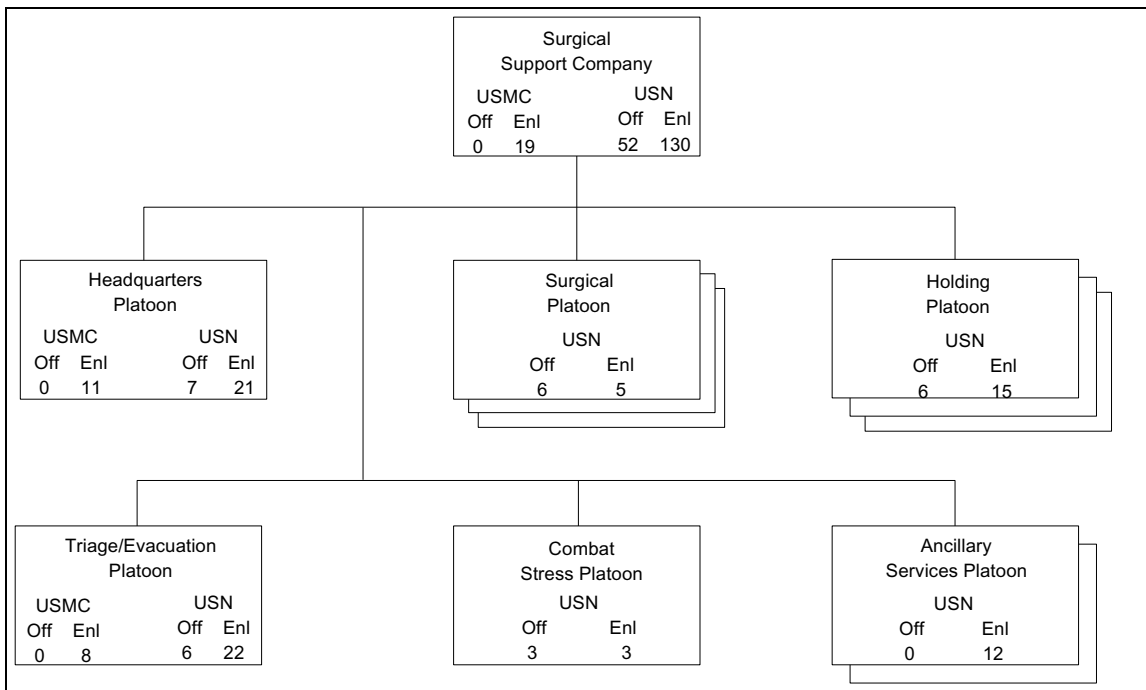

Figure 5-36. Surgical Support Company, Medical Battalion.

e. Administrative Capabilities

The company is capable of self-administration for assigned Marine Corps personnel, including patient affairs and medical regulating. Administrative support for assigned Navy personnel is provided by the service company of the H&S battalion.

f. Logistic Capabilities

(1) Supply. The company is capable of organic supply support to receive, temporarily hold, account for, and issue class VIII supplies and serves as an emergency resupply source for medical materiel for supported medical units. All other nonmedical supply support is provided by the H&S company of the medical battalion, and medical supply support is provided by the medical logistics company of the supply battalion.

(2) Maintenance. The company is capable of organizational (1st echelon) maintenance on organic equipment. Organizational (2d echelon) maintenance support for nonmedical equipment is provided by the H&S company of the medical battalion. Organizational (2d echelon) and intermediate (3d and 4th echelon) maintenance support for medical equipment is provided by the medical logistics

company of the supply battalion. Intermediate (3d and 4th echelon) maintenance support for nonmedical equipment is provided by the maintenance battalion.

(3) Transportation. Transportation is limited to ground ambulances. Other transportation support, as required, is coordinated by the medical battalion.

(4) General Engineering. Engineering support, as required, is provided by the engineer support battalion.

(5) Health Services. The company is capable of organic medical support. Dental support is provided by the dental battalion.

(6) Services. Services support, as required, is provided by the service company of the H&S battalion.

(7) Messing. Food service support is provided by the H&S company of the medical battalion.

(8) Selected Items of Equipment. See table 5-27.

5038. Shock-Trauma Platoon, Headquarters and Service Company, Medical Battalion

a. Mission

The shock-trauma platoon provides direct medical support to the MEF, including collecting, clearing, and evacuating casualties from supported MEF elements, and provides medical treatment facilities for resuscitative treatment care and temporary holding of casualties.

b. Tasks

- w Establish and operate clearing stations, as required.
- w Establish medical treatment facilities for resuscitative treatment and temporary holding of casualties.
- w Provide and coordinate medical evacuation.
- w Provide medical support to personnel of other Services and nations as provided in applicable regulations and agreements and provide humanitarian care as required by international law.

c. Concept of Organization

The shock-trauma platoon is the smallest mobile medical support element of the medical battalion and is the first medical treatment facility of the MAGTF in support of the BAS. The eight shock-trauma platoons are structured to

facilitate task organization for operations conducted by the battalion in support of the MEF, the MEF(FWD), or any combination of smaller MAGTFs. The platoon consists of a stabilization section and a collecting and evacuation section. (See figure 5-37.) Each collecting and evacuation section has two tactical ambulances for collecting casualties from the next forward medical support echelon, and the stabilization section has 5-ton trucks to move the shock-trauma platoon personnel and equipment.

(1) Command and Control. The H&S company commander directs and controls command support functions relating to operations, administration, and logistics/CSS for the platoon.

(2) Firepower. Organic firepower is limited to individual weapons and crew-served weapons for personal protection and for defense of medical installations in accordance with applicable international law.

(3) Mobility. Organizational vehicles provide ground mobility. Vehicles, personnel, and equipment of the platoon are helicopter transportable.

(4) Communications. The platoon is capable of single-channel communications support, including VHF and HF single-channel radios, VHF and HF vehicular single-channel radios, and analog switchboard and telephone support.

d. Concept of Employment

The stabilization section provides the nucleus for a ten flow-

TAM Number	Item	Quantity
A2169	Radio set, AN/VRC-90A	8
B0055	Bath shower unit	2
B1180	Ice making machine, flake	1
B1645	Refrigeration unit, rigid box	4
B1710	Refrigerator, rigid box, 350 ft ³	4
D0880	Trailer, tank, water, 400 gal, M149A2	3
D1001	Truck, ambulance, M997	8
D1158	Truck, util, M998	1

Table 5-27. Selected Items of Equipment for the Surgical Support Company.

through bed (litter) facility. The stabilization section can provide evacuation stations for emergency treatment, triage, and ambulance transfer points. Although a degree of mobility is sacrificed in providing a patient treatment facility, the shock-trauma platoon must maintain the capability to evacuate their casualties and move in support of BASs and the MAGTF elements it serves. The methods by which this facility is established, displaced, and relocated must keep pace with the mobility and flexibility demanded by MAGTF operations. One way a shock-trauma platoon may be employed is as part of a mobile CSSD.

e. Administrative Capabilities

Personnel/administrative support for assigned Navy and Marine Corps personnel is performed by the H&S company of the medical battalion.

f. Logistics Capability

(1) Supply. The platoon is capable of limited organic supply support to receive, temporarily hold, account for, and issue class VIII supplies. The platoon also serves as a limited emergency resupply source for medical materiel for supported medical units. All other nonmedical supply support is provided by the H&S company of the medical battalion; medical supply support is provided by the medical logistics company.

(2) Maintenance. Class VIII medical and dental equipment support has additional specific maintenance requirements that differ from normal Marine Corps maintenance procedures for ground combat equipment. The maintenance levels established by Marine Corps Bulletin 4790, *Medical and Dental Equipment Maintenance*, and the MCO P4790.2 series will be used.

(3) Transportation. Organizational vehicles of the company provide limited mobility. Transportation support is required from the motor transport battalion to effect displacement.

(4) General Engineering. Engineering support, as required, is provided by the engineer support battalion.

(5) Health Services. The platoon is capable of organic medical support. Dental support is provided by the dental battalion.

(6) Services. Services support, as required, is provided by the service company of the H&S battalion.

(7) Messing. Food service support is provided by the H&S battalion or by the supported CSSE.

5039. Dental Battalion

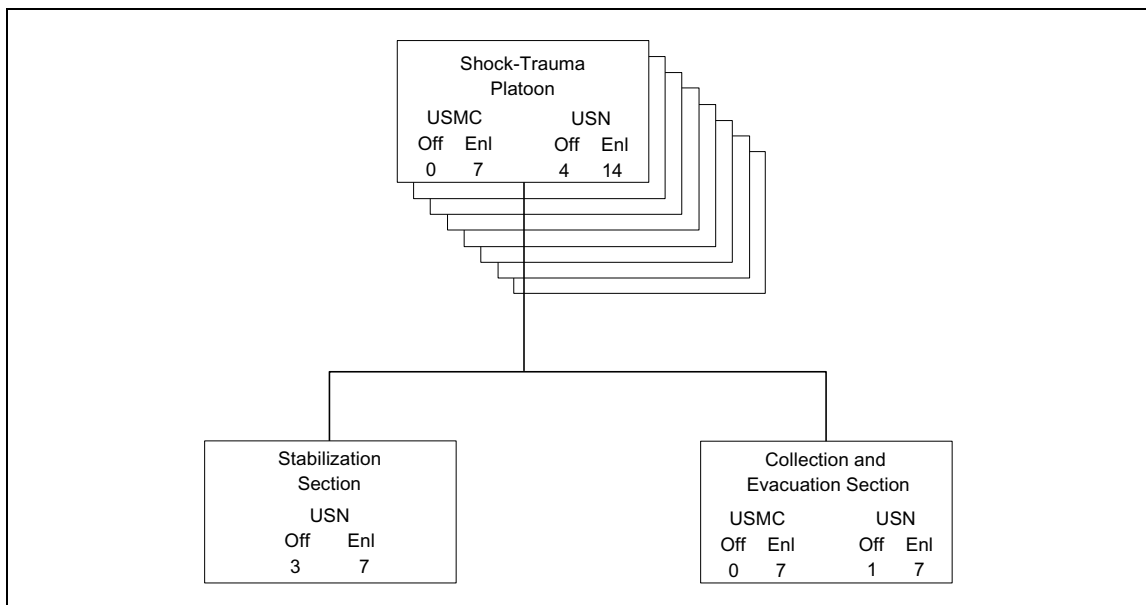

FIGURE 5-37. SHOCK-TRAUMA PLATOON, H&S COMPANY, MeDICAL BATTALION.

a. Mission

The dental battalion provides general support dental health care to the MEF.

b. Tasks

- w Provide a comprehensive program of dental health care for the MEF.
- w Coordinate MEF dental health care support requirements.
- w Provide dental detachments, as required, to support MAGTFs smaller than a MEF.
- w Supervise implementation of dental health care delivery programs for the MEF.

c. Concept of Organization

The battalion is organized to plan, coordinate, and supervise dental health care for the MEF. It is structured to facilitate task organization for operations conducted by the battalion in support of the MEF, or any combination of smaller MAGTFs operating in widely separated geographical areas. (See figure 5-38 on page 5-76.)

(1) Command and Control. The battalion commander excises command and control of the battalion through the battalion staff, the dental company commanding officers, and the H&S company commander. He directs and controls command support functions relating to operations, administration, and logistics/CSS for the battalion.

(2) Firepower. Organic firepower capability is limited to individual weapons for personal security and defense of dental installations in accordance with applicable international law.

(3) Mobility. Organizational vehicles of the battalion, transportable by fixed-wing aircraft and heavy-lift rotary wing aircraft, provide limited mobility. Transportation support is required from the motor transport battalion to effect displacement.

(4) Communications. Communications support is provided by the communications company of the H&S battalion.

(5) Intelligence. Intelligence support is provided by the H&S battalion.

(6) Security. Security support is provided by the H&S battalion.

d. Concept of Employment

The battalion provides general support dental health care for the MEF. Each dental company is capable of supporting a major subordinate element of the MEF. Detachments may be formed to provide necessary assistance in the care and/or evacuation of casualties or to support separate units.

e. Administrative Capability

Administrative support for assigned Navy and Marine Corps personnel is provided by the service company of the H&S battalion.

f. Logistic Capabilities

(1) Supply. The battalion is capable of organic supply support. Class VIII medical supply support is provided by the medical logistics company.

(2) Maintenance. The battalion is capable of organizational (1st and 2d echelon) maintenance on organic dental and nondental equipment and intermediate (3d echelon) maintenance on organic dental equipment. The medical logistics company of the supply battalion provides intermediate (3d and 4th echelon) maintenance support for dental equipment and maintains the ADALs. Intermediate (3d and 4th echelon) maintenance support for nondental equipment is provided by the maintenance battalion.

(3) Transportation. The battalion is capable of organic transportation support for command and administrative purposes.

(4) General Engineering. Engineering support, as required, is provided by the engineer support battalion.

(5) Health Services. Medical support is provided by H&S battalion, and dental support is provided by the dental battalion.

(6) Services. Services support, as required, is provided by the service company of the H&S battalion.

(7) Messing. Food service support is provided by the headquarters company of the H&S battalion. When the

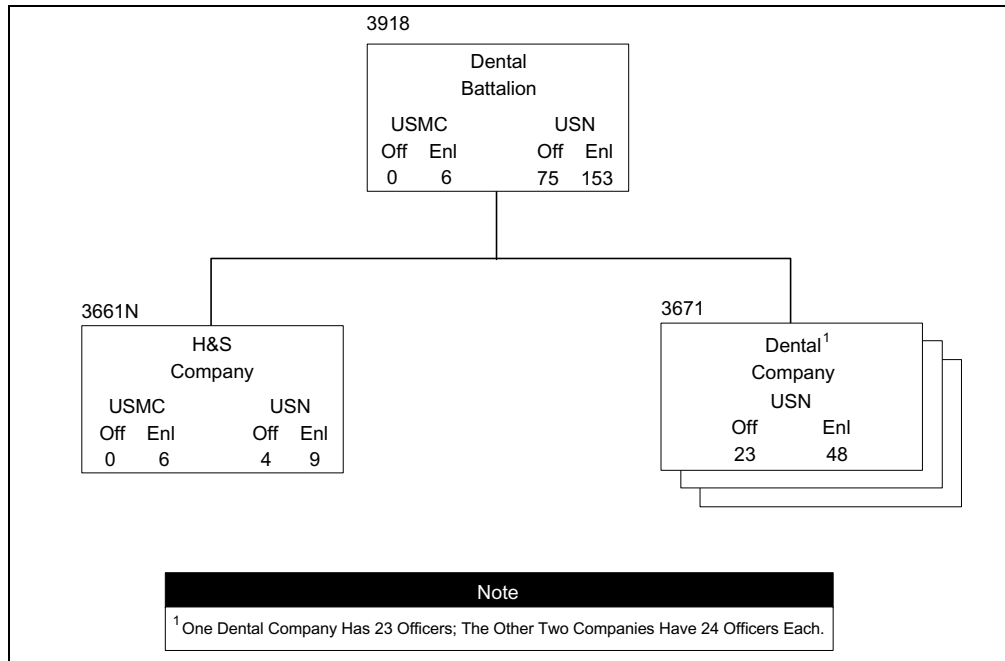

Figure 5-38. Dental Battalion.

dental battalion is collocated with the medical battalion, food service support may be provided by the medical battalion.

5040. Headquarters and Service Company, Dental Battalion

a. Mission

The H&S company of the dental battalion provides command, control, and command support functions.

b. Tasks

- w Provide command support functions for the operation of the battalion.
- w Assist with and coordinate professional matters such as quality assurance, infection control, dental readiness, the dental information retrieval system, and professional and in-service training for the battalion.

c. Concept of Organization

The company is organized to plan, coordinate, and supervise command support functions for the battalion. It is structured to facilitate task organization for operations conducted by the battalion in support of MAGTF operations. (See figure 5-39.)

(1) Command and Control. The company commander directs and controls command support functions relating to operations, administration, and logistics/CSS for the company.

(2) Firepower. Organic firepower capability is limited to individual weapons for personal security and defense of dental installations in accordance with applicable international law, which defines company personnel as *personnel employed in the administration of medical treatment facilities*. Marine Corps personnel assigned to this company are classified as noncombatants under the provisions of international law.

(3) Mobility. The company is helicopter transportable and requires transportation support from the motor transport battalion to effect displacement.

(4) Communications. Communications support is provided by the communications company of the H&S battalion.

d. Concept of Employment

The company normally operates from the FCSSA to provide centralized command and control facilities and administrative support for the battalion. As required, it task

organizes administrative support detachments operating in widely dispersed geographic areas.

e. Administrative Capability

Administrative support for assigned Navy and Marine Corps personnel is provided by the service company of the H&S battalion.

f. Logistic Capabilities

(1) Supply. The company is capable of organic supply support. Class VIII medical supply support is provided by the medical logistics company of the supply battalion.

(2) Maintenance. The company is capable of organizational (1st and 2d echelon) maintenance on organic equipment. Intermediate (3d and 4th echelon) maintenance support, as required, is provided by the maintenance battalion for nondental equipment and by the medical logistics company of the supply battalion for dental equipment.

(3) Transportation. The company is capable of organic transportation support for command and administrative purposes.

(4) General Engineering. Engineering support, as required, is provided by the engineer support battalion.

(5) Health Services. Medical support is provided by H&S battalion, and dental support is provided by the dental company.

(6) Services. Services support, as required, is provided by the service company of the H&S battalion.

(7) Messing. Food service support usually is provided by the headquarters company of the H&S battalion. When the dental battalion is collocated with the medical battalion, food service support may be provided by the H&S company of the medical battalion.

5041. Dental Company, Dental Battalion

a. Mission

The dental company provides general support dental health care to the major subordinate elements of the MEF.

b. Tasks

- w Maintain MAGTF units in an acceptable state of dental readiness.
- w Provide a comprehensive dental program for the MEF, including emergency dental treatment and specialty disciplines with the exception of maxillofacial surgery.

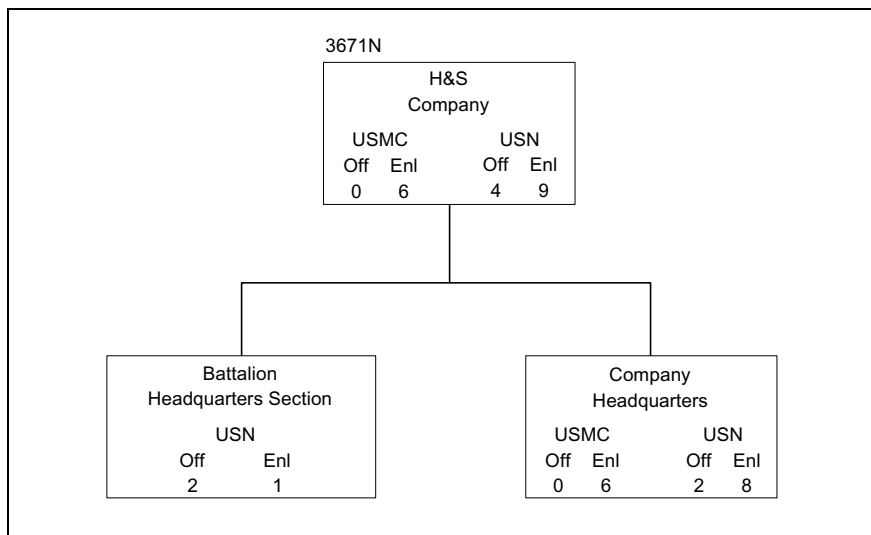

Figure 5-39. H&S Company, Dental Battalion.

c. Concept of Organization

Dental companies are organized to provide support to each of the major subordinate elements of the MEF and to facilitate task organization as detachments in support of MAGTFs smaller than a MEF. (See figure 5-40.)

(1) Command and Control. The dental company commanding officer directs and controls command support functions relating to operations, administration, and logistics/CSS for the company.

(2) Firepower. Organic firepower capability is limited to individual weapons for personal security and defense of dental installations in accordance with applicable international law.

(3) Mobility. The company is helicopter transportable and requires transportation support from the motor transport battalion to effect displacement.

(4) Communications. Communications support is provided by the communications company of the H&S battalion.

d. Concept of Employment

The company provides general support dental health care to the MEF. Task-organized dental support detachments can be employed to support any element of the MEF or to reinforce other dental and/or medical units. They may also

be employed to render necessary assistance in the care and evacuation of mass casualties.

e. Administrative Capability

Administrative support for assigned Navy and Marine Corps personnel is provided by the service company of the H&S battalion.

f. Logistic Capabilities

(1) Supply. Supply support for class VIII supplies and ADAL items is provided by the medical logistics company of the supply battalion. All other nonmedical supply support is provided by the H&S company of the dental battalion.

(2) Maintenance. The company is capable of organizational (1st and 2d echelon) maintenance on organic equipment. Intermediate (3d and 4th echelon) maintenance support, as required, is provided by the maintenance battalion for nondental equipment and by the medical logistics company of the supply battalion for dental equipment.

(3) Transportation. The company is capable of organic transportation support for command and administrative purposes.

(4) General Engineering. Engineering support, as required, is provided by the engineer support battalion.

(5) Health Services. The company is capable of organic dental support. Medical support is provided by H&S battalion.

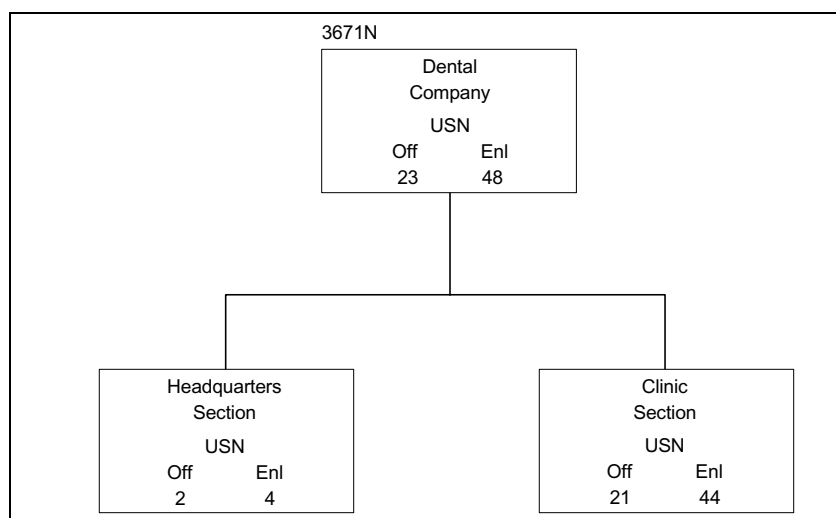

Figure 5-40. Dental Company, Dental Battalion.

(6) Services. Services support, as required, is provided by the service company of the H&S battalion.

(7) Messing. Food service support normally is provided by the headquarters company of the H&S battalion. When the dental battalion is collocated with the medical battalion, food service support may be provided by the medical battalion.

Chapter 6

MAGTF Command Elements and Supporting Units

6001. General

This chapter addresses MAGTF command elements (CE) and units that are not subordinate to either the Marine division, the MAW, or the FSSG.

6002. Marine Expeditionary Force Command Element

a. Mission

To provide command and control of the Marine Expeditionary Force (MEF). The MEF Command Element (CE) is responsible for the command, control, direction, planning and coordination of corps-level air, ground, and logistical operations of assigned forces, normally consisting of one or more Marine divisions, Marine aircraft wings, and force service support groups, and other separate units.

b. Tasks

The MEF CE performs the following general functions:

- w Exercises tactical direction over units assigned by the Marine component, FMF commander, naval component commander, or a joint force commander (JFC).
- w Coordinate and conduct the deep, close, and rear battles throughout its designated area of operations.
- w Determine the detailed composition of the force.
- w Develop overall tactical plans for command and control, intelligence, maneuver, fires, logistics and force protection.
- w Develop all-source intelligence and counterintelligence required.

- w Plan and coordinate civil affairs, civic action matters, and military-diplomatic operations.
- w Plan, conduct, and maintain communications and information systems operations with subordinate, higher, adjacent, and joint or allied forces.
- w Provide the nucleus of the Arrival Assembly Operations Group for MPF operations
- w Coordinate the submission of requirements for the receipt and distribution of material resources for logistic support of assigned forces.
- w Function as a joint force land, air, or maritime component headquarters when designated and when provided with appropriate augmentation from the supported unified commander and the other service components.

c. Organization

The MEF CE consists of—

- w Command Section.
- w G-1 Division (personnel and administration).
- w G-2 Division (intelligence and counterintelligence).
- w G-3 Division (operations and training).
- w G-4 Division (logistics).
- w G-5 Division (plans).
- w G-6 Division (communications and information systems).
- w Comptroller Division.
- w Communication Security Management Office.
- w Special Operations Training Group.
- w Staff Judge Advocate Branch.

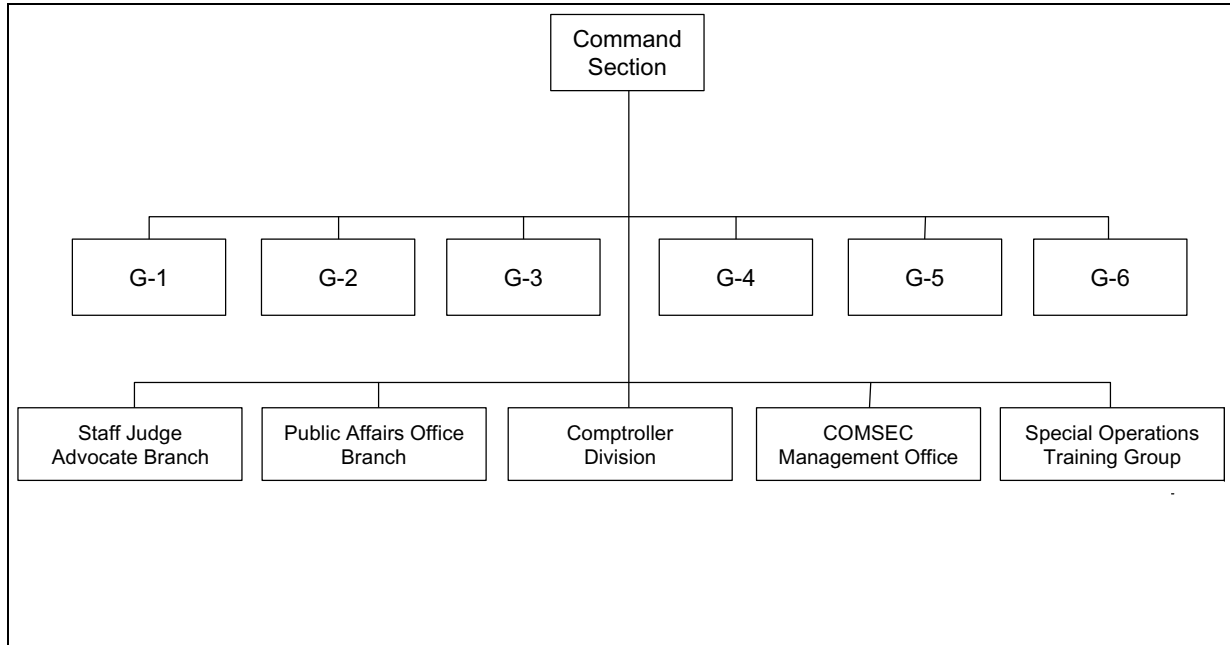

Figure 6-1. MEF Command Element.

w Public Affairs Office Branch.

See figure 6-1.

The MEF CE maintains the ability to deploy a forward warfighting CE, MEF (FWD), capable of exercising operational control of assigned and/or attached forces. The MEF (FWD) will function either as the precursor for the deployment of the entire MEF, or conduct operations of limited scope or duration, when deployment of the entire MEF is not necessary.

d. Concept of Employment

The size and concept of employment of a deployed MEF can vary greatly depending on the requirements of the mission. A MEF can deploy and employ not only its own units, but also units from other standing MEFs, the Marine Corps Reserve, or other Services. The MEF Command Element is capable of independent employment, but may be satellited on the headquarters of one of its major subordinate commands. It is capable of up to Corps-sized missions across the range of military operations, including amphibious assault and sustained operations ashore in any environment. In doing so, the MEF CE is capable of executing command and control of four to five Marine/joint/combined maneuver divisions along with other major subordinate aviation, combat service support, and other commands. Normally,

there is no requirement for a subordinate Marine Air-Ground Task Force CE. However, forces employed in widely separated areas may require a subordinate MAGTF CE.

e. Support Capabilities

(1) Communications and Information Systems (CIS)

(a) The G-6, Communications and Information Systems Officer, is responsible for the formulation of CIS plans and policies for the MEF.

(b) The MEF CE has sufficient CIS resources to satisfy internal requirements. Its communications detachment is responsible for the installation, operation, and maintenance of single and multi-channel channel radio, tactical telephone, and satellite systems. Access will typically be required to pertinent MAGTF local area networks (LANs) and wide area networks (WANs). Additionally, joint world wide intelligence communications system (JWICS), secret internet protocol router network (SIPRNET), and non-classified internet protocol router network (NIPERNET) will be required for all operations.

(2) Firepower. Organic firepower capability is limited to individual and crew-served weapons.

(3) Administrative. When the entire MEF Command Element is employed, it is capable of self-administration.

(4) Maintenance. The MEF command element is authorized and capable of performing 1st and 2d echelon maintenance on all organic equipment.

(5) Supply. The MEF command element is capable of performing organic supply functions.

(6) Transportation. The MEF command element have organic vehicular transportation. However, each will depend on the supported unit or other external assets for transportation of the entire unit in one echelon.

(7) Medical. The MEF command element is capable of providing routine and emergency treatment and preparation for evacuation by using its organic medical section.

(8) Messing. The MEF command element is not capable of providing organic food service support.

6003. Marine Expeditionary Unit, Special Operations Capable [MEU (SOC)] CE

a. Mission

The mission of the MEU (SOC) CE is to provide command and control to the MEU (SOC). The MEU (SOC) CE is responsible for the command and control, direction, planning, and coordination of air, ground, and logistic operations of assigned forces, consisting of a Marine battalion landing team, Marine composite squadron, MEU service support group, and other separate units.

b. Tasks

A MEU (SOC) CE may be tasked to conduct, and be responsible for planning and the MEU (SOC)'s execution of, the following tasks listed by four broad operational categories:

- (1) Amphibious Operations.** Amphibious Assault; Amphibious Raid; Amphibious Demonstration; and, Amphibious Withdrawal.
- (2) Direct Action Operations.** In-Extremis Hostage Recovery (IHR); Seizure/Recovery of Offshore Energy

Facilities (GOPLAT); Visit, Board, Search and Seizure Operations (VBSS); Specialized Demolition Operations; Tactical Recovery of Aircraft and Personnel (TRAP); Seizure/Recovery of Selected Personnel or Material; and, Counter-Proliferation (CP) of Weapons of Mass Destruction (WMD).

(3) Military Operations Other Than War (MOOTW). Peace Operations (Peacekeeping and Peace Enforcement); Security Operations; Non-combatant Evacuation Operations (NEO); Reinforcement Operations; Joint/Combined Training/Instruction Team; and, Humanitarian Assistance/Disaster Relief.

(4) Supporting Operations. Tactical Deception Operations; Airfield/Port Seizure; Limited Expeditionary Airfield Operations; Show of Force Operations; JTF Enabling Operations; and Force Protection Operations .

c. Organization

A MEU (SOC) CE contains the following sections:

- w Command section.
- w Chaplain section.
- w S-1 section.
- w S-2 section.
- w S-3 section.
- w S-4 section.
- w S-6 section.
- w Headquarters commandant.
- w Public affairs section.

See figure 6-2 on page 6-4.

d. Concept of Employment

The MEU(SOC) CE is employed as the organic command and control element of the MEU(SOC), capable of single site or split-based operations. Additionally, the MEU(SOC) CE may be employed for a limited period as the forward/tactical C2 echelon of a joint task force headquarters or a larger MAGTF command element.

e. Administration, Logistics, and Other Support Capabilities

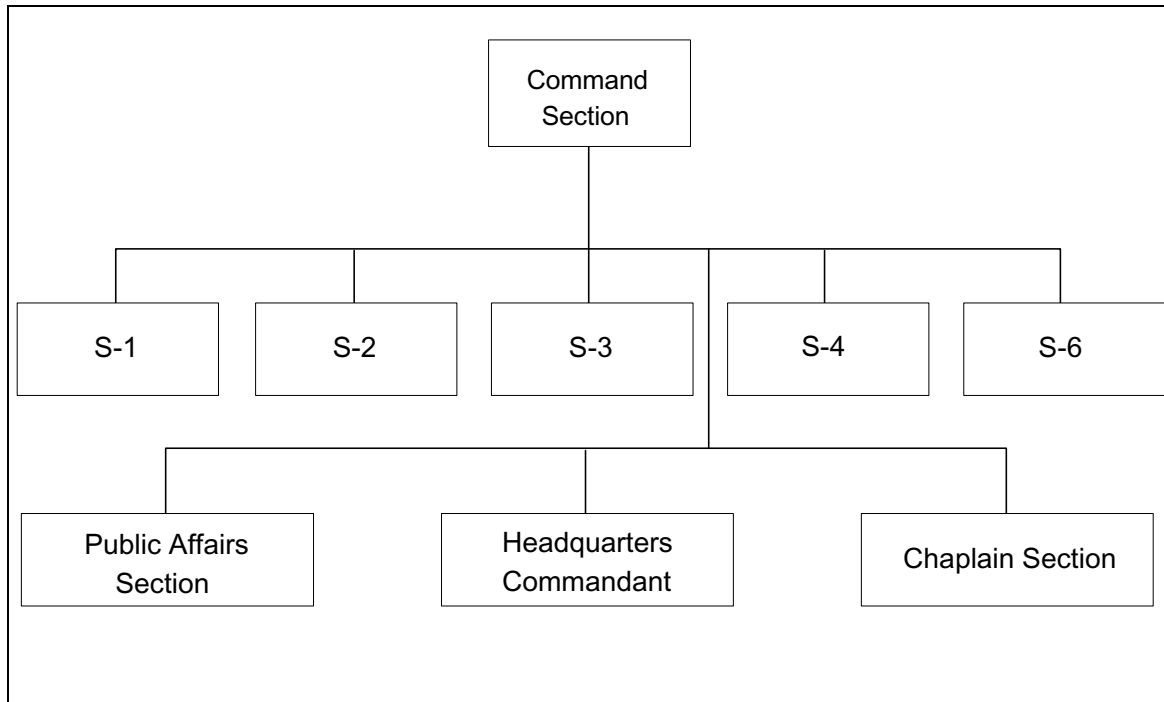

Figure 6-2. MEU (SOC) Command Element.

(1) Command and Control

(a) The CO, MEU(SOC) exercises command and controls the MEU(SOC) CE. The commander, exercises command and control over the subordinate elements of the MEU(SOC): the ground combat element (GCE); the aviation combat element (ACE); the combat service support element (CSSE); and other attached/supporting forces.

(b) Communications and Information Systems

(CIS). In addition to permanently assigned personnel of the S-6 Section, the MEU(SOC) CE is augmented by a detachment from the Communication Battalion to provide communications connectivity and information systems support with higher headquarters, subordinate MEU(SOC) elements, attached units, supporting units, and follow-on forces.

(2) **Intelligence.** In addition to permanently assigned personnel of the S-2 Section, the MEU(SOC) CE is augmented by detachments from the Radio Battalion, Intelligence Company, Counterintelligence/HUMINT Company, and Force Reconnaissance Company to conduct intelli-

gence, counterintelligence, surveillance and reconnaissance operations.

(3) **Firepower.** Individual weapons constitute the firepower organic to the MEU(SOC) CE .

(4) **Mobility.** Navy shipping provides the MEU (SOC) CE strategic, operational, and tactical mobility when deployed at sea. Navy and MEU(SOC) subordinate elements provides the MEU(SOC) CE tactical mobility from ship-to-shore. Finally, the MEU(SOC) CE's limited organic transport assets along with those of subordinate elements provides the MEU(SOC) CE tactical mobility ashore.

(5) **Administration.** The MEU(SOC) CE is capable of self-administration for permanently assigned personnel. When augmented with a detachment from the MEF Headquarters Group, the CE is also capable of self-administration for all CE attachments.

(6) **Maintenance.** The CE performs 1st echelon maintenance on all organic equipment.

(7) Supply. S-4 Section supply personnel coordinate supply support that is provided by the assigned CSSE.

(8) Transportation. Transportation support beyond organic capability is provided by the subordinate elements: primary ground transportation is provided by the MSSG, while air transportation is provided by the ACE.

(9) Health Services. Subordinate elements of the MEU(SOC), primarily the CSSE, and the Navy ship(s) on which the MEU(SOC) CE is embarked, provide medical support to the MEU(SOC) CE.

(10) Messing. The CSSE provides deployed messing support for the MEU(SOC) CE when ashore. Messing support is provided by the Navy ship when embarked.

6004. Marine Expeditionary Force (MEF) Headquarters Group (MHG)

a. Mission

To provide administrative and service support to the MEF command element (CE) and to intelligence, counterintelligence, ground reconnaissance, communications and information systems (CIS), and liaison organizations subordinate to the MEF CE.

b. Tasks

w

Provide administrative and service support to the MEF CE and MHG subordinate units.

w Provide headquarters commandant support to the MEF CE.

c. Organization

Each MEF has one MHG. MHG internal organization may vary. Each MHG will include the MEF's intelligence company, communication battalion, and force reconnaissance company. It is anticipated that the Marine liaison group will be subordinate to I MEF's MHG. Figure 6-3 shows personnel numbers for MHG, I MEF.

MHG, I MEF, was activated during late FY98. MHGs for II and III MEFs will be activated during FY99.

Each MEF intelligence company will be deactivated during FY99. Its mission and tasks, as well as expected new ones, are anticipated to be assigned to the intelligence battalion, with activation to occur during FY99. Final issues associated with this change were being resolved at the time this publication went to print.

The current air/naval gunfire liaison company (ANGLICO) organic to each MEF will be deactivated during FY99. Personnel and other resources are anticipated to be assigned to the MEF liaison group, I MEF, with a mission to provide liaison support to all Marine operating forces when assigned. Final issues associated with this change were being resolved at the time this publication went to print.

d. Concept of Employment

The commander, MHG, has ADCON of MHG subordinate units. During operations the MHG or its detachments are

MEF Headquarters Group (T/O #4701B)			
USMC		USN	
Off	Enl	Off	Enl
13	202	3	8

Figure 6-3. MEF Headquarters Group, I MEF.

OPCON to the supported MAGTF commander. The commander will exercise control of MHG/detachment through the respective staff section: intelligence and reconnaissance elements through the G/S-2, CIS elements through the G/S-6, and Marine liaison elements through the G/S-3. Support relationships may vary widely and will be established by the supported commander, in accordance with the situation. (See paragraphs 6006d, 6009d, and 6010d for additional information on the concept of employment of MHG subordinate units.)

e. Administrative, Logistic, and Other Support Capabilities

(1) Communications and Information Systems.

The MHG and its subordinate elements have sufficient organic communications to satisfy its internal voice communications circuits requirements.

The MHG and its subordinate elements have sufficient information systems resources to satisfy internal requirements. Access will typically be required to pertinent MAGTF LANs and WANs. Secret Internet Protocol Router Network (SIPRNET) and Joint Worldwide Intelligence Communications System (JWICS) access will generally be required either for the MHG/detachment or subordinate elements.

(2) Firepower. Organic firepower capability is limited to individual and crew-served weapons.

(3) Administrative. The MHG is capable of self-administration. Detachments operating in support of smaller MAGTFs, however, are not usually capable of self-administration; administrative support must be provided by the supported unit.

(4) Maintenance. The MHG is authorized and capable of performing 1st and 2d echelon maintenance of all organic equipment. (See paragraphs 6006 and 6010 for more information on their unique maintenance capabilities.)

(5) Supply. The MHG is capable of performing organic supply functions. Supply support of MHG detachments is provided by the supported unit.

(6) Transportation. The MHG and its detachments have organic vehicular transportation. Both will depend on

the supported unit or other external assets for transportation of the entire unit in one echelon.

(7) Medical. The MHG is capable of providing routine and emergency treatment and preparation for evacuation by using its organic medical section. Medical support for MHG detachments must be provided by the supported unit.

(8) Messing. The MHG is capable of providing organic food service support. Food service support of MHG detachments is provided by the supported unit.

6005. Radio Battalion

a. Mission

The mission of the radio battalion is to provide tactical signals intelligence (SIGINT), ground-based electronic attack (EA), communications security (COMSEC) monitoring, and special intelligence (SI) communication support to the MAGTF.

b. Tasks

- w Conduct tactical (SIGINT) support operations in support of any MAGTF operation, including intercept, radio direction finding (DF), recording, and analysis of communications and noncommunications signals, and SIGINT processing, analysis, production, and reporting.
- w Conduct EA against enemy or other hostile communications.
- w Conduct COMSEC monitoring and reporting on friendly force communications.
- w Provide SI communications support and cryptographic guard (personnel and terminal equipment) in support of MAGTF CEs and battalion operations. (Note: communications connectivity for SI communications is provided by the communications unit supporting the MAGTF CE.)
- w Provide SIGINT support units (SSUs) to MAGTFs that are task organized with designated SIGINT, EA, sensitive compartmented information (SCI) communications, and other capabilities.
- w Provide radio reconnaissance teams with specialized insertion and extraction capabilities (combat rubber raiding craft, fast rope, rappel, helocast,

static line parachute) to provide specified SIGINT and EA support during advance force, preassault, or deep postassault operations.

c. Organization

There are two radio battalions within the operating force: 1st Radio Battalion, which is under the OPCON of COMMARFORPAC and is responsible for providing support to it and I and III MEF; and 2d Radio Battalion, which is responsible for support to MARFORLANT and II MEF. 1st Radio Battalion consists of an H&S company and three operational companies (T/O numbers 4737D and 4735D); 2d Radio Battalion consists of an H&S company and two operational companies (T/O numbers 4737M and 4735M). The operational companies of the radio battalion are not tactical organizations, but instead serve as training and administrative units from which personnel and equipment are drawn to form task-organized SSUs. A radio battalion SSU will be task organized around all or most of the following elements: a headquarters element, an operations control and analysis center or collections/DF element, an EA element, an SI communications element, a service support element, and a radio reconnaissance element. See figure 6-4.

During operations the radio battalion or its task-organized SSUs are under OPCON of the MAGTF commander, who exercises this control through the G-2/S-2. Radio battalions/SSUs are employed in either general support or direct support. Under general support, battalion/SSU elements are tasked by the MAGTF commander through his G-2/S-2¹ to satisfy specified requirements of the entire force. Alternatively, SSUs may be placed in direct support of a subordinate commander to provide focused SIGINT/EA for particular phases of an operation. Finally, when MAGTFs of less than a full MEF size are deployed, a SSU will normally be attached to the MAGTF CE (e.g., with a MEU(SOC)).

An entire radio battalion will support a MEF. MAGTFs of smaller size will generally be supported by a task-organized SSU. The radio battalion headquarters/SSU headquarters and its S-3/operations control and analysis center sections will normally locate in the vicinity of the MAGTF CE main command echelon/combat intelligence center to facilitate operational planning, command and control, and support. SIGINT support teams from the battalion's operational companies will be task organized in a manner that is consistent with the MAGTF's and subordinate units' missions, the

d. Concept of Employment

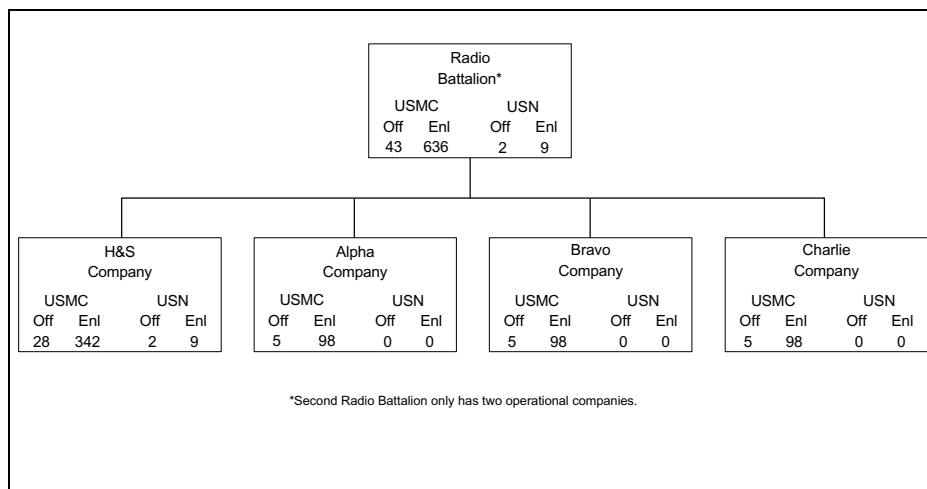

Figure 6-4. Radio Battalion Organization.

¹ The principal mission of the radio battalion/SSU is to support MAGTF intelligence operations. Accordingly, the G-2/S-2 has the preponderance of staff responsibility for radio battalion/SSU operations. However, EA and COMSEC monitoring tasks; operations responsibilities and thus will be the responsibility of the MAGTF G-3/S-3. Close coordination between the G-2/S and G-3/S-3 is necessary to ensure effective, coordinated radio battalion/SSU operations.

commander's intent, the threat, and the operating and electromagnetic environments. SIGINT support teams and other battalion/SSU elements will generally be employed on an area basis in general support of the MAGTF; smaller SSUs may be either attached to or placed in direct support of MAGTF subordinate units when required. In all cases the radio battalion commander/SSU officer in charge will command and control battalion/SSU operations. Regardless of the specified command relationships and task organization, the radio battalion commander/SSU officer in charge will retain technical control over battalion/SSU operations to optimize the effectiveness of SIGINT operations.

e. Administrative, Logistic, and Other Support Capabilities

(1) Communications and Information Systems

(a) The battalion/SSU has sufficient organic communications to establish internal battalion voice communications circuits, for connectivity with specified SIGINT broadcast systems, and for terminal record SI communications facilities to support both MAGTF CE and battalion/SSU requirements. Communication paths for all record SI communications must be provided by the communications unit supporting the MAGTF CE.

(b) The radio battalion/SSU has sufficient information systems resources to satisfy internal requirements. Access will typically be required to pertinent MAGTF local area networks (LANs) and wide area networks (WANs). Additionally, Secret Internet Protocol Router Network (SIPRNET) and Joint Worldwide Intelligence Communications System (JWICS) access will be required for all radio battalion/SSU operations.

(2) **Firepower.** Organic firepower capability is limited to individual and crew-served weapons.

(3) **Mobility.** The battalion is capable of vehicular movement by using organic equipment. External support is required to move the entire battalion in one echelon. All battalion mission equipment is helicopter transportable.

(4) **Administrative.** When the entire radio battalion is employed, it is capable of self-administration. SSUs, however, are not capable of self-administration; administration must be provided by the supported unit.

(5) **Maintenance.** The battalion is authorized and capable of performing 1st and 2d echelon maintenance of all organic equipment, 3d echelon maintenance of all Marine Corps-furnished communications-electronics equipment, and 4th echelon maintenance of Marine Corps-furnished SIGINT, EW, and SI communications-electronic equipment that is unique to the radio battalion. SSUs will generally deploy with a limited organic maintenance capability tailored to perform maintenance of all communications equipment that is unique to SIGINT, EW, and SI functions; all other maintenance support must be provided by the supported unit.

(6) **Supply.** The battalion is capable of performing organic supply functions. Supply support of SSUs is provided by the supported unit.

(7) **Transportation.** The battalion and SSUs have organic vehicular transportation. However, each will depend on the supported unit or other external assets for transportation of the entire unit in one echelon.

(8) **Medical.** The radio battalion is capable of providing routine and emergency treatment and preparation for evacuation by using its organic medical section. Medical support for SSUs must be provided by the supported unit.

(9) **Messing.** The battalion is capable of operating one battalion field dining facility. SSU messing is provided by the supported unit.

(10) **Selected Items of Equipment.** See table 6-1.

6006. Intelligence Company

a. Mission

The intelligence company organizes, trains, and equips task-organized intelligence detachments for service with MAGTFs or other commanders as directed.

b. Tasks

(1) **Intelligence Company Headquarters.** During both garrison and tactical operations, the mission of the intelligence company headquarters is to coordinate administrative, operational, training, and logistical support for all subordinate company units. Additionally, during tactical operations the intelligence company headquarters will assist the MEF G-2 with establishment and operation of the surveillance and reconnaissance center. The following paragraphs describe

the missions and tasks for intelligence company subordinate units.

(2) Topographic Platoon. The topographic platoon’s mission is to provide tailored geospatial information and services to MAGTFs and other commands as directed.

Tasks include:

- w Provide tailored, mission-oriented topographic map products to supplement standard National Imagery and Mapping Agency (NIMA) maps and charts.

TAM Number	Item	Quantity
A0258	Communications central, AN/MSC-63A	3
A0283	Communications/intelligence system, team portable, AN/PSQ-9	5
A0412	Jamming systems, communications, AN/ULQ-19(V)1	12
A0517	Direction finder set, AN/PRD-12	16
A0817	Global positioning set, manpack, AN/PSN-8	3
A0917	Terminal, communications satellite, manpack, AN/PSC-3	9
A0966	Mobile EW support system (MEWSS), AN/MLQ-36A	6
A1219	Radio reconnaissance equipment program, SIGINT suite	9
A1930	Radio set, AN/MRC-110A	10
A1935	Radio set, AN/MRC-138(V)	14
A2050	Radio set, AN/PRC-77	52
A2051	Radio set, manpack (PLRS), AN/PSQ-4	4
A2065	Radio set, AN/PRC-104B(V)	14
A2069	Radio set, AN/PRC-113(V)3	10
A2070	Radio set, AN/PRC-119A	37
A2130	Radio set, AN/VRC-12	4
A2151	Radio set, vehicle (PLRS), AN/VSQ-1	4
A2168	Radio set, AN/VRC-89A	8
A2169	Radio set, AN/VRC-90A	5
A2532	TCO system	4
A2629	Technical control and analysis center (TCAC) (PIP), AN/MYQ-8	4
A2631	TCAC, AN/TSQ-130(V)5	3
B0891	Generator set, 10 kW, 60 Hz, MEP-803A	12
B0953	Generator set, 30 kW, 60 Hz, MEP-805A	8
B1021	Generator set, 60 kW, 60 Hz, MEP-806A	8
D0850	Trailer, cargo, 3/4 ton, M101A1	4
D0860	Trailer, cargo, 1 1/2 ton, M105A2	5
D0880	Trailer, tank, water, 400 gal, M149A1	4
D1059	Truck, cargo, 5 ton, 6 x 6, without winch, M923A1	41
D1158	Truck, utility, cargo/troop carrier, 1/4 ton, HMMWV, M998	50
D1212	Truck, wrecker, 5 ton, 6 x 6, M936	1
E0950	LAV, maintenance/recovery (LAV-R)	1
J3320	Truck, hand lift, pallet type	3

Table 6-1. Selected Items of Equipment for the Radio Battalion.²

² Items and quantities may vary between the battalions. Refer to the current T/Es for accurate quantities for each radio battalion 1st Radio Battalion, N4638, and 2d Radio Battalion, N4738.

- w In conjunction with the MAGTF G-2/S-2 MAGTF all-source fusion center (AFC), collect, analyze, synthesize, and disseminate terrain information and intelligence.
- w Prepare map substitutes such as overlays, overprints, photomosaics, map revisions, and multi-color charts. Revise and reproduce in limited quantities combat charts, coastal charts, port charts, and harbor charts. Products may include terrain models (three-dimensional models), line-of-sight studies, range fan studies, terrain factor overlays, hydrographic charts, landing zone studies, and so on.
- w Prepare coastal hydrographic surveys from the six-fathom depth curve (or from where the Navy ocean survey ends) to the high-water line. The survey is extended beyond the beach to the first line of communications that allows lateral movement behind the beach. Collect coastal data regarding trafficability, routes of egress, and inland water bodies.
- w Prepare second-order horizontal and vertical geodetic/topographic surveys that encompass astronomic, geodetic, and satellite positioning, as well as geodetic and magnetic azimuth surveys.
- w Prepare additional intelligence products, as required, including those that depict cross-country movement, cover and concealment, observation and fields of fire, avenues of approach, flooding and drainage, stream and river gauging, lines of communications, and obstacles.

(3) Sensor Control and Management Platoon

(SCAMP). The SCAMP's mission is to plan, control, and manage the employment of unattended ground remote sensor equipment in support of MAGTFs or other commands as directed. Tasks include:

- w Plan for the employment of unattended ground remote sensors.
- w Operate, monitor, and maintain unattended ground remote equipment.
- w Report items of military significance in response to designated priority intelligence requirements (PIRs) and other intelligence taskings.
- w Train personnel (e.g., infantry Marines, ground reconnaissance Marines, aircrews) to implant unattended ground remote sensor equipment.
- w Implant air-delivered remote sensor equipment by using rotary-wing aviation assets.
- w Provide liaison teams for remote sensor air delivery by fixed-wing aircraft.

(4) Force Imagery Interpretation Unit (FIU).

The FIU's mission is to provide imagery analysis and imagery intelligence (IMINT) support for MAGTFs and other commands as directed. Tasks include:

- w Exploit and analyze all-source, multisensor imagery to derive intelligence pertaining to installations, dispositions, strengths, and activities of various conventional and nonconventional forces.
- w Employ imagery methods and techniques in the planning and tasking of multisensor platforms, those both organic and external to the MAGTF.
- w Conduct exploitation and assist in imagery management.
- w Provide IMINT reports, limited imagery-derived products, and secondary imagery to the MAGTF and other commanders.
- w Conduct liaison with the Marine Corps Imagery Support Unit (MCISU) (see paragraph 6008) for the purpose of obtaining imagery products in support of MAGTF intelligence requirements.

(5) Direct Support Teams. The mission of direct support teams is to provide enhanced intelligence analytical, production, and dissemination capabilities to designated supported-unit intelligence sections. Following is a list of direct support team tasks:

- w Provide connectivity to the MAGTF AFC for the receipt and dissemination of intelligence to the supported unit.

- w Assist the supported unit's intelligence officer in the formulation and management of external intelligence support requirements.
- w Tailor MAGTF AFC and other external-source intelligence products to the needs of the supported unit.
- w Perform intelligence preparation of the battlespace in support of future operations planning.
- w Prepare intelligence products to support detailed mission planning and execution by maneuver elements.
- w Augment and enhance the dissemination efforts of the supported unit's intelligence section.
- w Act as liaison between the supported unit and the MAGTF AFC.

d. Concept of Employment

The intelligence company is under OPCON of the MEF commander, who exercises this control through the G-2. During operations, intelligence company units are employed in either general support or direct support. Under general support, intelligence company elements are tasked by the MAGTF commander through the G-2/S-2 to satisfy the requirements of the entire force. Alternatively, task-organized detachments consisting of elements from some or all of the intelligence company's subordinate units may be placed in direct support of a subordinate commander to focus intelligence support for particular phases of an operation or to create enhanced intelligence nodes in support of subordinate elements. Finally, when MAGTFs of less than a full MEF

c. Organization

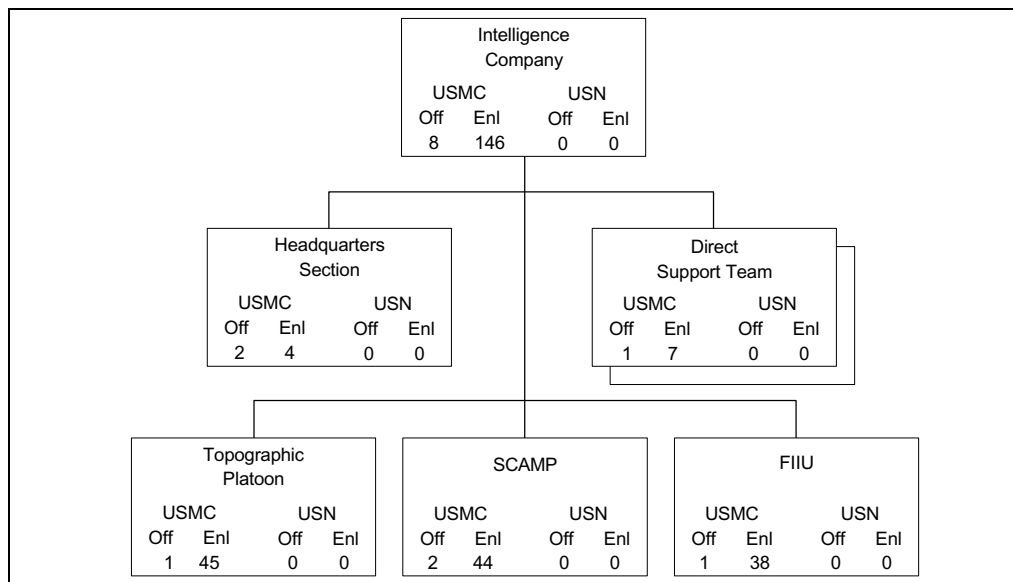

Figure 6-5. Intelligence Company Organization.

³ Within I MEF, 1st Intelligence Company is administratively subordinate to MEF headquarters group. Within II MEF, 2d Intelligence Company is subordinate to 2d Radio Battalion. Within III MEF, 3d Intelligence Company is subordinate to Headquarter Battalion. The organization of Marine Corps intelligence and reconnaissance units is undergoing review and is subject to change. Accordingly, the organization, manpower numbers, equipment, and quantities for intelligence and reconnaissance units presented in this chapter may vary significantly within units. Refer to the following T/O numbers for current information: Intelligence Company, 4707D; Topographic Platoon, 1st and 2d Intelligence Company 4708; 3d Topographic Platoon, 4708 SCAMP, 4709; FIIU, 4710F; and the direct support teams, 4712F (1st Intelligence Company), 4712I (2d Intelligence Company), and 4712H (3d Intelligence Company).

size are deployed, task-organized detachments from intelligence company will normally be attached to the MAGTF CE.

The intelligence company, task-organized detachments, or its subordinate units' concepts of employment are situationally dependent. The following paragraphs provide basic employment planning guidance.

(1) Topographic Platoon. This platoon is capable of supporting simultaneously three MEUs/SPMAGTFs in addition to a MEF. This capability will generally be as follows.

- w MEU or a SPMAGTF—Support will be provided by a terrain analysis team.
- w MEF—Support will be provided by the entire topographic platoon.

(2) SCAMP. When operating in support of the MEF, the SCAMP will generally be employed as a platoon. SCAMP employment in support of MEF subordinate units or MAGTFs smaller than a MEF will generally be task organized around either a sensor employment squad or a sensor employment team. A MEU (SOC) typically has no organic SCAMP element; instead, the parent MEF maintains a CONUS-based sensor employment team ready to deploy on 24-hours notice if a MEU (SOC) requires support.

(3) FIU. This unit is capable of supporting one MEF. Support to MEUs or other smaller MAGTFs will generally be provided by an imagery analysis detachment.

(4) Direct Support Team. Primary employment of direct support teams is as organic teams either attached to or placed in direct support of a designated subordinate commander (e.g., the MEF main effort, a MEU, or an SPMAGTF). Additionally, when not so employed the direct support teams will generally augment the MAGTF AFC.

e. Administrative, Logistic, and Other Support Capabilities

(1) Administrative. The intelligence company and its subordinate units are not capable of self-administration. Administrative support is provided by the MEF unit to which it is ADCON or other designated unit. Administrative support for intelligence company detachments is provided by the supported unit.

(2) Communications and Information Systems. The intelligence company and its subordinate elements have sufficient communications resources to support internal company/detachment command and control, operations, and intelligence requirements. Intelligence company subordinate units' communications capabilities generally consist of short- and medium-range voice communications equipment. There are, however, no communications personnel organic to the intelligence company. Communications requirements beyond these must be provided by the supported unit.

All elements have sufficient information systems resources to satisfy internal needs. Each will generally require access to pertinent LANs and designated WANs. The topographic platoon and the direct support teams will typically require access to the SIPRNET; the FIU likewise typically requires access to the SIPRNET as well as to the JWICS. The direct support teams also may require JWICS access.

(3) Firepower. Organic firepower capability is limited to individual and crew-served weapons.

(4) Maintenance. The intelligence company and its subordinate units are capable of 1st echelon maintenance of organic equipment. With the following exceptions, all higher maintenance is provided by the MEF unit to which it is ADCON CSSEs, or the supported unit.

(a) SCAMP. The SCAMP is capable of 1st through 4th echelon maintenance on all organic remote sensor equipment. It is the only designated intermediate maintenance activity for tactical remote sensor equipment; therefore, evacuation via the CSSE intermediate maintenance activity is not required.

(b) FIU. The FIU is capable of 1st through 4th echelon maintenance of organic imagery equipment.

(5) Supply. Supply support is provided by the MEF unit to which it is ADCON; CSSEs; or the supported unit.

(6) Transportation. The intelligence company has limited organic vehicular transportation support to support the company and subordinate units' operations. External transportation support from the MEF unit to which it is ADCON, CSSEs, or the supported unit is necessary to displace all company elements.

(7) Medical. Medical support is provided by the MEF unit to which it is ADCON, CSSEs, or the supported unit.

(8) Messing. Messing support is provided by the MEF unit to which it is ADCON, CSSEs, or the supported unit.

(9) Selected Items of Equipment. See table 6-2 on page 6-14.

6007. Counterintelligence (CI)/Human Intelligence (HUMINT) Company

a. Mission

The mission of the CI/HUMINT company is to provide CI support and conduct CI and HUMINT operations in support of the MEF, other MAGTFs, or other units as directed.

b. Tasks

- w Conduct tactical CI activities and operations, including CI force protection source operations, in support of MAGTF or joint operations.
- w Conduct screening, debriefing and interrogation of personnel of intelligence/CI interest.

- w Direct and supervise intelligence activities conducted within the interrogation facility and the document and material exploitation facility.
- w Perform CI and terrorism threat analysis and assist in the preparation of CI and intelligence studies, orders, estimates, and plans.
- w Conduct low-level-source HUMINT operations.
- w Collect and maintain information designed to identify, locate, and recover captured or missing personnel.
- w Debrief friendly personnel recovered from EPW, hostage, or detainee status.
- w Translate and exploit captured documents.
- w Assist in the conduct of tactical exploitation of captured materiel and equipment.
- w Conduct limited CI investigations during combat or operations other than war.
- w Conduct CI surveys and evaluations.
- w Conduct technical surveillance countermeasures (TSCM) operations.
- w Maintain foreign area specialists who can provide sociological, economic, cultural and geo-political information about designated countries.

c. Organization. Each MEF has one organic CI/HUMINT company.⁴ The CI/HUMINT company consists of a headquarters section, a CI platoon, an interrogator-translator platoon, and three to five HUMINT exploitation teams. The CI platoon is organized into a platoon headquarters, four CI teams (CITs), and a TSCM team. The interrogator-translator platoon is organized into a platoon headquarters and six interrogator-translator teams. See figure 6-6.

d. Concept of Employment

The CI/HUMINT company combines the MEF's CI and interrogator-translator capabilities into one organization to provide unity of effort in HUMINT operations and support

⁴ The first CI/HUMINT company stood up during FY98, with all three companies operational by FY00. CI/HUMINT personnel ; equipment currently are located within the interrogator-translator platoon and the CITs of each MEF's intelligence compar Refer to the following T/O numbers for current information: CI/HUMINT Company, I MEF, 4714F; CI/HUMINT Company, II MEF, 4714I; and CI/HUMINT Company, III MEF, to be determined.

to force protection. The company is employed in accordance with the concept of intelligence support, the CI plan, and the intelligence operations plan developed by the MAGTFs and may be used to support joint operations. MAGTF G-2/S-2. The CI/HUMINT company or task-organized HUMINT exploitation team is usually employed in general support of the MAGTF. Subordinate elements of the company may be placed in general support of the MEF, placed in direct support of subordinate commands, or attached to subordinate elements. Additionally, a task-organized detachment will be provided to most subordinate elements.

e. Administrative, Logistic, and Other Support Capabilities

TAM Number	Description	Quantity
A0447	Relay set, data, tactical remote sensor system (TRSS), AN/USQ-80A	6
A0504	Digital Terrain Analysis Mapping System (DTAMS), AN/PYQ-1	6
A0809	Geographic Information System-1, GIS-1	1
A0810	Geographic Information System-2, GIS-2	1
A0811	Geographic Information System-3, GIS-3	1
A0870	Intermediate suite, IAS, AN/UYQ-69(V)2	1
A0879	Tactical exploitation group	1
A0884	Joint Services Imagery Processing System (JSIPS), AN/TSQ-166 (V)	1
A1217	Interpretation set, photo, unit	2
A1218	Interpretation set, photo, team	6
A1221	Monitor, portable, AN/USQ-121	24
A1260	Navigation set, satellite, signals, precise lightweight Global Positioning System receiver (PLGR), AN/PSN-11	34
A2065	Radio set, AN/PRC-104B(V)	4
A2069	Radio set, AN/PRC-113(V)3	3
A2070	Radio set, AN/PRC-119A	12
A2072	Radio set, AN/GRC-231A(V)2	5
A2306	Sensor system, monitor, mobile, AN/MSC-77	5
A2477	Survey set, geodetic precision	8
A3169	Topographic set, AN/TSQ-204	1
A3255	Sensor, ground, unattended, AN/GSQ-257	5
B0891	Generator set, 10 kW, 60 Hz, MEP-803A	12
B0730	Generator set, 3 kW, 60 Hz, MEP-016B	4
B0891	Generator set, 10 kW, 60 Hz, MEP-803A	3
B0953	Generator set, 30 kW, 60 Hz, MEP-805A	1
B1045	Generator set, 100 kW, 60 Hz, MEP-007B	2
D0080	Chassis, trailer, general purpose, 1/2 ton, M353	2
D0085	Chassis, trailer, 3/4 ton, two wheel, M116A3	3
D0850	Trailer, cargo, 3/4 ton, M101A1	10
D1059	Truck, cargo, 5 ton, 6 x 6, without winch, M923A1	1
D1061	Truck, cargo, 5 ton, extra-large wide bed, M928	4
D1158	Truck, utility, cargo/troop carrier, 1/4 ton, HMMWV, M998	24

Table 6-2. Selected Items of Equipment for the Intelligence Company.⁵

⁵ Quantities shown are based on T/Es for 2d Intelligence Company as of 22 October 1997. Quantities for 1st and 3d Intelligence Company may differ. Refer to the following T/Es for current information: 1st Intelligence Company, N4617; 2d Intelligence Company, N4717; and 3d Intelligence Company, N4817.

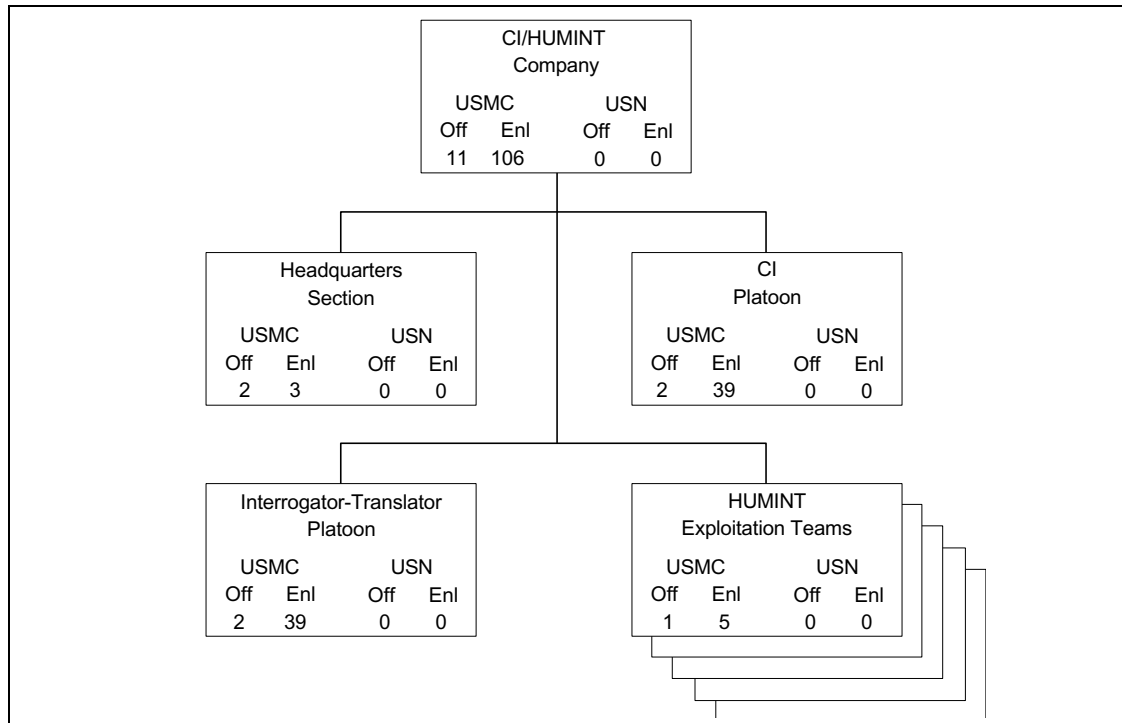

Figure 6-6. CI/HUMINT Company Organization.

(1) Administrative. The CI/HUMINT company and its subordinate units are not capable of self-administration. Administrative support is provided by the MEF unit to which it is ADCON or the supported unit. Administrative support for HUMINT exploitation team and CI/HUMINT company detachments is provided by the supported unit.

(2) Communications and Information Systems

(a) The CI/HUMINT company and its subordinate elements have sufficient communications resources to support internal company/detachment command and control, operations, and intelligence requirements. CI/HUMINT company subordinate units' communications capabilities generally consist of short- and medium-range voice communications equipment. There are, however, no communications personnel organic to the CI/HUMINT company. Communications requirements beyond these must be provided by the supported unit.

(b) All CI/HUMINT company elements have sufficient information systems resources to satisfy internal needs. Each

will generally require access to pertinent LANs and designated WANs. CI/HUMINT company elements will also typically require access to the SIPRNET, to certain CI special communications, and possibly to JWICS.

(3) Firepower. Organic firepower capability is limited to individual and crew-served weapons.

(4) Maintenance. The CI/HUMINT company and its subordinate units are capable of 1st echelon maintenance support of organic equipment. All higher maintenance is provided by the MEF unit to which it is ADCON, or CSSEs, or the supported unit.

(5) Supply. Supply support is provided to the CI/HUMINT company by the MEF unit to which it is ADCON, CSSEs, or the supported unit.

(6) Transportation. The CI/HUMINT company has limited organic vehicular transportation support to support company and subordinate units operations. External transportation support from the MEF unit to which it is ADCON, CSSEs, or the supported unit is necessary to displace all company elements.

(7) Medical. Medical support is provided by the MEF unit to which it is ADCON, CSSEs, or the supported unit.

(8) Messing. Messing support is provided by the MEF unit to which it is ADCON, CSSEs, or the supported unit.

(9) Selected Items of Equipment. See table 6-3.

6008. Marine Corps Imagery Support Unit

a. Mission

The mission of the MCISU is to provide imagery analysis support for the MARFORs, MEFs, other MAGTFs, the Marine Corps supporting establishment, and other commands as directed.

b. Tasks

- w Support and assist the operating forces in all matters pertaining to imagery exploitation, employment of the MCISU, and the maintenance of all organic imagery and imagery-related equipment.

- w Exploit and analyze national imagery to derive intelligence pertaining to installations, dispositions, strengths, and activities of conventional and nonconventional forces.
- w Conduct exploitation and related tasks in response to direction from the executive agent.
- w Provide IMINT reports, limited imagery-derived products, and limited secondary imagery to MAGTF commanders and others as directed.
- w Conduct liaison with the FIU for the purpose of providing national imagery products to support MAGTF commanders.
- w Conduct liaison with national program offices as required to support day-to-day unit activities.
- w Manage, update, and maintain national databases as required to support production responsibilities and daily operations.

c. Organization

There is only one MCISU, located at Camp Pendleton, CA. It consists of a headquarters section, one exploitation

TAM		
Number	Description	Quantity
A03809	Counterintelligence equipment, technical surveillance	1
A0420	Communications system, counterintelligence	
8		
A0890	Facsimile, digital, lightweight, AN/UXC-7	9
A1260	Navigation set, satellite (PLGR), AN/PSN-11	25
A2030	Radio set, AN/PRC-68A	2
A2065	Radio set, AN/PRC-104B(V)	8
A2070	Radio set, AN/PRC-119A	23
A2145	Radio set, AN/VRC-46	5
A2167	Radio set, AN/VRC-88A	20
D0850	Trailer, cargo, 3/4 ton, two wheel, M101A3	7
D1158	Truck utility cargo/transport carrier, 1/4 ton, HMMWV, M998	35

Table 6-3. Selected Items of Equipment for the CI/HUMINT Company.⁶

⁶ T/Es for the CI/HUMINT company were not finalized at the time of publication of this manual. The items and quantities shown here were drawn from those designated for the interrogator-translator platoon and the CITs in the T/Es for the intelligence companies of 22 October 1997. Refer to the current T/Es for accurate, current information.

team, and one SI communications section (T/O 4710E). The MCISU is under the administrative and operational control of the commanding general, I MEF. Command, less OPCON and ADCON, rests with the Commander, Marine Corps Force Pacific. See figure 6-7.

d. Concept of Employment

The MCISU is capable of simultaneously supporting the operating forces and the supporting establishment 24 hours a day, 7 days a week. Support will normally be provided from the MCISU garrison location at Camp Pendleton. If required, the MCISU can deploy in support of a single MAGTF or other command as directed.

e. Administrative, Logistic, and Other Support Capabilities

(1) Administrative. The MCISU is not capable of self-administration. Garrison support is provided by the 1st MEF headquarters group. When deployed, administrative support is provided by the supported unit.

(2) Communications and Information Systems.

The MCISU has a limited amount of communications and information systems equipment to support deployments and will require support from the supported unit. Communications circuits required by the MCISU will be designated TSP-01 circuits.

(3) Firepower. Organic firepower capability is limited to individual weapons.

(4) Maintenance. The MCISU is capable of 1st echelon maintenance of all organic equipment and 1st through 4th echelon maintenance of organic imagery equipment.

(5) Supply. Supply support is provided by the 1st MEF headquarters group or by the supported unit.

(6) Transportation. The MCISU has no organic transportation capability. The supported unit must provide all transportation support during deployments.

(7) Medical. All medical support during deployments must be provided by the supported unit.

(8) Messing. Messing support is provided by the supported unit.

(9) Selected Items of Equipment. See table 6-4.

6009. Force Reconnaissance Company

a. Mission

The mission of the force reconnaissance company is to conduct amphibious reconnaissance, surveillance, and limited-scale raids in support of the MEF, other MAGTFs, or JTFs as directed.

b. Tasks

w Conduct amphibious reconnaissance and deep ground reconnaissance and surveillance to observe, identify, and report enemy activity and collect and report other information of military significance.

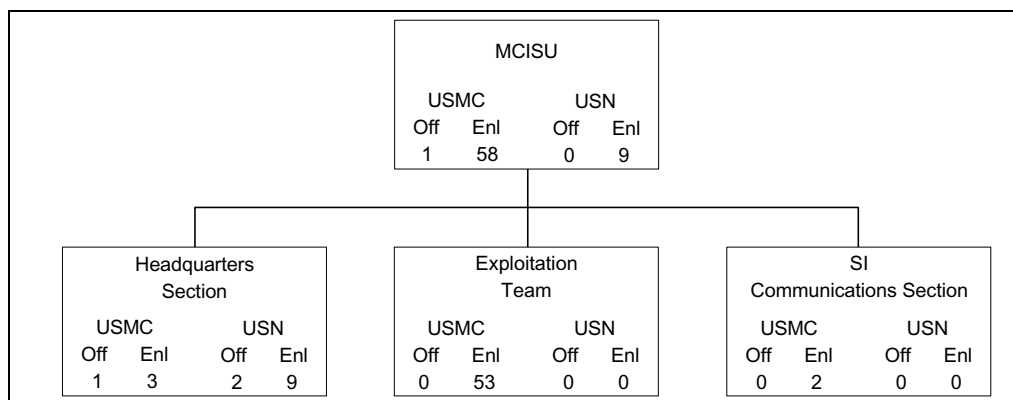

Figure 6-7. MCISU Organization.

- w Conduct specialized terrain reconnaissance, including reconnaissance of hydrography, beaches, roads, bridges, routes, urban areas, helicopter landing zones, airborne drop zones, landing craft air cushion (LCAC) landing zones, and aircraft forward operating sites.
- w When properly organized with other forces, equipment, or personnel, conduct engineer, NBC, mobile, and other unique reconnaissance missions.
- w Implant and/or recover sensors and beacons.
- w Conduct initial terminal guidance (ITG) for helicopters, landing craft, and parachutists.
- w Engage selected targets with supporting arms or organic weapons, as directed, including terminal guidance of precision-guided munitions.
- w Conduct post-strike reconnaissance to determine and report battle damage to a specific target or area.
- w Conduct limited-scale raids. These operations include, but are not limited to, seizing, damaging, or destroying critical enemy targets; performing static maritime platform and maritime interdiction operations; capturing selected enemy personnel; and recovering sensitive items or personnel.

consists of a headquarters platoon, a supply and services platoon, and five reconnaissance platoons. (5th Force Reconnaissance Company has three reconnaissance platoons.) Each reconnaissance platoon consists of 3 teams containing 4 men each, for a total of 15 teams per company, except for 5th Force Reconnaissance Company, which has 9 teams. See figure 6-8.

d. Concept of Employment

(1) The force reconnaissance company normally operates under the staff cognizance of the MAGTF G-2/S-2 for reconnaissance and surveillance missions and under the staff cognizance of the MAGTF G-3/S-3 for offensive missions. The basic operating unit is the team. However, platoons or task-organized elements may be employed to accomplish certain tasks.

(2) Force reconnaissance operations should have a defined scope and duration, with planned exfiltration. Teams are usually inserted into the supported commander’s area of interest (usually the deep area), often well beyond the supporting arms and reserve elements of the enemy’s committed forces, to collect and report information in response to the commander’s PIRs.

(3) When required by the situation, the company or detachments may be placed in direct support of or attached to smaller MAGTFs or to MEF elements other than the CE. Normally a force reconnaissance detachment is attached to a MEU(SOC).

c. Organization

Each MEF has one organic force reconnaissance company: 1st Force Reconnaissance Company with I MEF, 2d Force Reconnaissance Company with II MEF, and 5th Force Reconnaissance Company with III MEF. ⁸ The company

TAM Number	Description	Quantity
A0871	Suite, analysis system, intelligence, AN/UYQ-69(V)1	1
A0884	Joint Services Imagery Processing System (JSIPS), AN/TSQ-166(V)	1
A1080	Network workstation (V2), RSC-1X	6
A1217	Interpretation set, photo, unit	4
A1218	Interpretation set, photo, team	9

Table 6-4. Selected Items of Equipment for the MCISU.⁷

⁷ The T/E number for the MCISU is N4010.

⁸ The organization of Marine Corps intelligence and reconnaissance units is undergoing review and is subject to change. Accordingly, the organization, manpower numbers, equipment and equipment quantities for intelligence and reconnaissance units shown in this chapter may vary significantly within units. Refer to the following T/O numbers for current information: 1st and 5th Force Reconnaissance Companies, 4718D, and 5th Force Reconnaissance Company, 4719C.

(4) Because force reconnaissance company units routinely operate beyond the range of the MAGTF's supporting arms, the company must maintain the capability to clandestinely insert and extract units over extended distances. Such means include foot movement, surface or subsurface swimming, vehicles, rotary- or fixed-wing aircraft, small boats, landing craft, and commercial assets. All teams are capable of using closed-circuit underwater breathing apparatus, open-circuit SCUBA, and submarine lock-out. All teams also are capable of static-line and military free-fall parachuting.

(5) Deployed teams use standard techniques of small-unit scouting and individual movement. Unless the mission requires otherwise, force reconnaissance teams will avoid contact with the enemy or indigenous people. Teams either observe from vantage points or physically reconnoiter the areas of interest. As directed, teams report by radio and/or during postmission debriefings.

(6) When conducting offensive operations, force reconnaissance company elements employ the techniques described above to reach their objective sites. Conducting actions at the objective area, they employ close-quarter battle, standard tactical assault, or sniper techniques to neutralize or destroy enemy targets and/or to recover designated personnel or materiel.

(7) Teams assigned to ITG missions reconnoiter the landing area and provide last-minute visual or electronic terminal guidance to flight, wave, or stick leaders. ITG missions terminate with the arrival of the helicopter support team, U.S. Navy beach party, LCAC landing zone control teams, U.S. Army Pathfinder teams, or U.S. Air Force

combat control teams, which then assume traffic-control functions.

e. Administrative, Logistic, and Other Support Capabilities

(1) **Administrative.** The force reconnaissance company is capable of self-administration. Administrative support for deployed platoons and detachments is provided by the supported unit.

(2) **Communications and Information Systems.** The force reconnaissance company and its subordinate elements have sufficient communications resources to support internal company/detachment command and control, operations, and intelligence requirements. Communications capabilities generally consist of short-, medium-, and long-range voice communications equipment.

The headquarters of the force reconnaissance company or its detachments have sufficient information systems resources to satisfy internal needs. They will generally require access to pertinent LANs and WANs to support mission planning and coordination.

(3) **Firepower.** Organic firepower capability is limited to individual weapons.

(4) **Maintenance.** The force reconnaissance company and its subordinate units are capable of 1st and 2d echelon maintenance support of organic equipment. Additionally,

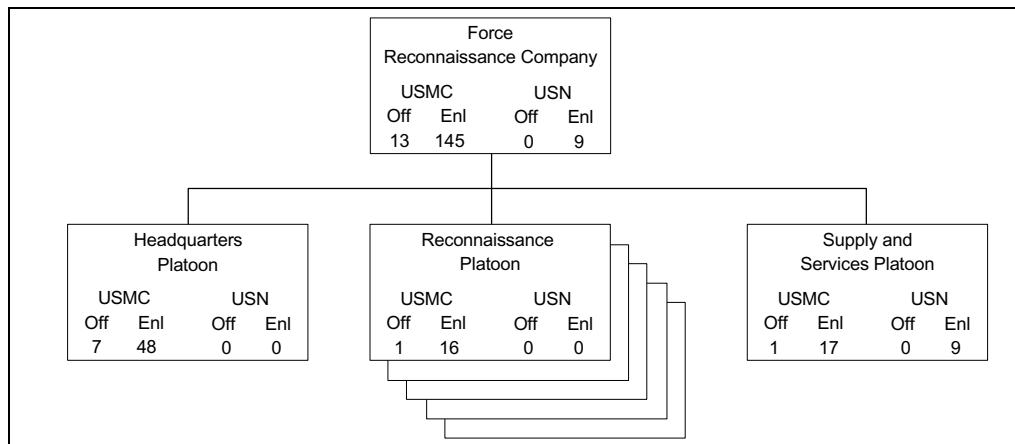

Figure 6-8. Force Reconnaissance Company Organization.

they are capable of 3rd and 4th echelon maintenance, short of fabrication, of all organic diving and parachute equipment. All higher maintenance is provided by the the MEF unit to which it is ADCON, CSSEs, or the supported unit.

(5) Supply. Supply support is provided by the MEF unit to which it is ADCON, CSSEs, or the supported unit.

(6) Transportation. The force reconnaissance company has limited organic vehicular transportation support to support company and subordinate unit operations. External transportation support from the MEF unit to which it is ADCON, CSSEs, or the supported unit is necessary to displace all company elements.

(7) Medical. The force reconnaissance company is capable of routine, emergency, and advance trauma treatment. Additionally, it can provide specially trained Navy corpsmen in support of its detachments.

(8) Messing. Messing support is provided by the MEF unit to which it is ADCON, CSSEs, or the supported unit.

(9) Selected Items of Equipment. See table 6-5.

6010. Communication Battalion

a. Mission

The mission of the communication battalion is to provide communications and information systems support to MARFOR component headquarters and MAGTF CEs.

b. Tasks

w Plan and engineer command and control systems for the MARFOR headquarters and MAGTF CEs, as required.

w Provide internal CE communications for the supported MARFOR component headquarters, MEF CE, MEU(SOC) CE, or other MAGTF CE, which includes the following tasks:

{ Installation, operation, and maintenance of network control facilities and system control facilities

{ Installation, operation, and maintenance of radio stations for command and control, intelligence operations, administrative, logistic, and other radio nets as required

{ Installation, operation, and maintenance of switchboard and telephone services

{ Installation, operation, and maintenance of the MEF digital transmission backbone by using cable and multichannel radio equipment

{ Installation, operation, and maintenance of digital switches to provide secure and nonsecure voice, facsimile, message, and data service to the MEF CE command echelons

{ Interfacing the MEF CE command and control systems with national systems, the Naval Telecommunications System, commercial telecommunications systems, and senior (CINC/JTF), adjacent, and subordinate systems and networks as required

{ Installation, operation, and maintenance of tactical LANs and WANs for MARFOR component headquarters and MEF CEs

{ Installation, operation, and maintenance of field message centers, radio links, and tactical switchboard/telephone systems for three MEU CEs.

w Provide communications connectivity and terminal facilities between the supported headquarters/CE and senior, adjacent, and subordinate headquarters.

w Provide the supported headquarters/CE with a Naval Telecommunications Systems entry and/ or, as appropriate, entry into the Defense Communications System.

w Provide communications-electronics equipment maintenance support to battalion general support and direct support companies.

c. Organization

Each MEF has an organic communication battalion: 9th Communication Battalion with I MEF, 8th Communication Battalion with II MEF, and 7th Communication Battalion with III MEF. Each communication battalion consists of a

TAM		
Number	Description	Quantity
A0425	Terminal, communications, auto, data (DACT)	25
A0498	Message system, digital, AN/PSC-2A	25
A0904	Base station, manpack SIDS	5
A0905	Out station, manpack SIDS	15
A0917	Terminal, communications, satellite, manpack, AN/PSC-3	1st, 22; 2d, 0; 5th, 6
A0918	Radio set, AN/PSC-5	10
A1700	Intrateam radio (ITR), team	90
A1935	Radio set, AN/MRC-138(V)	1
A2065	Radio set, AN/PRC 1-4B(V)	31
A2069	Radio set, UHF, AN/PRC-113(V)3	25
A2070	Radio set, manpack, AN/PRC-119A	15
A2073	Radio set, manpack, AN/PRC-119D	15
A2164	Radio set, AN/VRC-83(V)2	2
A2420	Navigation system, small unit	1st, 30; 2d, 59; 5th, 10
B0280	Camera set, still picture	6
C2278	Mask, oxygen, MBU-12P	113
C2284	Kit, rigging, aircraft	6
C2285	Kit, drop zone	6
C2286	Oxygen system, portable	113
C2288	Portable prebreather unit	12
C4547	Propulsion device, diver (DPD)	18
C4550	Equipment set, diving, open circuit	1st, 80; 2d, 120; 5th, 68
C4560	Recompression chamber system, transportable (TRCS)	3
C5560	Parachute, personnel, back, 28-ft diameter	12
C5590	Parachute, personnel, MC-1-1C	1st, 113; 2d, 350; 5th, 130
C5600	Parachute, reserve, personnel, troop	1st, 113; 2d, 350; 5th, 130
C5649	Parachute, personnel, troop, back, MC-5	1st, 113; 2d, 113; 5th, 84
D0850	Trailer, cargo, 3/4 ton, two wheel, M-101A3	6
D0860	Trailer, cargo, 1 1/2 ton, two wheel, M-105A2	3
D1059	Truck, cargo, 5 ton, 6 x 6, without winch, M-923A1	5
D1158	Truck, utility, cargo/troop carrier, 1/4 ton, HMMWV, M-998	16
E0870	Observation set, laser, infrared, AN/GVS-5	18
E0955	Light, aiming, infrared, AN/PAQ-4C	63 (None for 5th Force)
E1152	Goggles, night vision, individual, AN/PVS-7B	70
E1900	Telescope, observation, M-49	20
H2041	Kit, antenna, special operations, OE-452/PRC	21
H2327	Microphone, voice silencer, M-153/U	1st, 30; 2d, 40; 5th, 12
J3218	Rope, fast, 60 ft	1st, 20; 2d, 20; 5th, 6
J3219	Rope, fast, 90 ft	20 (1st Force Only)
J3221	Rope, fast, 120 ft	2d, 20; 5th, 12

Table 6-5. Selected Items of Equipment for the Force Reconnaissance Company. ⁹

⁹ Items and quantities were from the Force Reconnaissance T/E (draft) as of 22 October 1997. These may vary significantly within each company. Refer to the following T/Es for accurate, current information: 1st Force Reconnaissance Company, N4618; 2d Force Reconnaissance Company, N4718; and 5th Force Reconnaissance Company, N4818.

headquarters company, a general support company, one or three direct support companies,¹⁰ and a service company.¹¹ See figure 6-9.

d. Concept of Employment

During operations the communication battalion or its task-organized detachments are OPCON to the MAGTF commander, who exercises this control through the G-6/S-6. Elements of the battalion are organized to provide specified general or direct support of the MARFOR component commander or MAGTF CE. The MAGTF CE G-6/S-6 exercises staff cognizance over MAGTF communications; to facilitate system planning and engineering, the battalion conducts concurrent planning with the MAGTF G-6/S-6.

Elements of the communication battalion may be employed separately as task-organized detachments to support organizations smaller than a MEF CE, or the entire battalion may be employed to support larger MAGTF CEs. The commu-

n battalion will normally deploy as a task-organized unit or will deploy task-organized detachments in support of MARFOR headquarters and MAGTF CEs. In support of a MEF CE, the battalion in total will task organize to support the deployment. Upon notification, and before deployment of a smaller MAGTF CE or a MARFOR headquarters, a direct support communications company will be task-organized to support the deployment. The headquarters company includes the structure necessary to provide detachments to support three MEU CEs.

e. Administrative, Logistic, and Other Support Capabilities

(1) Communications and Information Systems.

The battalion and its detachments are fully capable of supporting internal operations with organic communications and information systems resources.

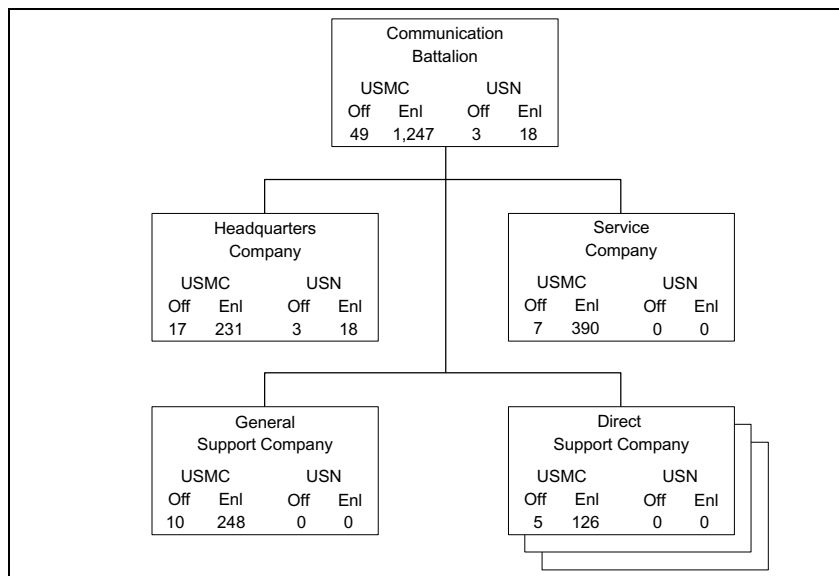

Figure 6-9. Communication Battalion Organization.

¹⁰7th Communications Battalion, III MEF, has one direct support company; both 8th Communications Battalion, II MEF, and 9th Communications Battalion, I MEF, have three direct support companies.

¹¹T/O numbers for the communications battalions are: 7th Communications Battalion, 4886H (headquarters company), 4887H (direct support company), 4884H (general support company), and 4885H (service company); and 8th and 9th Communications Battalions, 4886C (headquarters companies), 4883C (direct support companies), 4884C (general support companies), and 4885C (service companies).

(2) Firepower. Organic firepower capability is limited to individual and crew-served weapons.

(3) Mobility. The battalion is capable of vehicular movement by using organic equipment. External support is required to move the entire battalion in one echelon.

(4) Administrative. When the entire communication battalion is employed it is capable of self-administration. Detachments, however, are not capable of self-administration; administration must be provided by the supported unit.

(5) Maintenance. The battalion is capable of 1st echelon maintenance on all organic equipment; 2d echelon maintenance on assigned communications-electronics and motor transport equipment, infantry weapons, and mobile electric power generators; and 3d echelon maintenance on communications and information systems and electronics equipment, except for test equipment. Additionally, it is capable of limited maintenance on all assigned COMSEC equipment.

(6) Supply. The battalion is capable of performing organic supply functions. Supply support of detachments is provided by the supported unit.

(7) Transportation. The battalion and detachments have organic vehicular transportation. Each will depend on the supported unit or other external assets for transportation of the entire unit in one echelon.

(8) Medical. The battalion is capable of providing routine and emergency treatment and preparation via its organic medical section. Medical support for detachments must be provided by the supported unit.

(9) Messing. The battalion is capable of operating one field dining facility. Messing for detachments is provided by the supported unit.

(10) Selected Items of Equipment. See table 6-6 on page 6-24.

6011. Civil Affairs Group (CAG)

a. Mission

The CAG provides special staff support to the MEF during the planning, assault and consolidation phases of landing operations in naval campaigns, and may be utilized across the operational spectrum. It plans, advises, coordinates, conducts, supervises, and evaluates activities between military and civilian forces in order to minimize mission interference, and to maximize civilian support for landing force operations. These activities include interaction between the MEF and inhabitants; Host Nation civil, police, and military authorities; US. Non-military agencies; and a wide array of nongovernmental organizations (NGO's). The CAG supports the MEF's careful attention to local culture, customs, and traditions, in order to facilitate military operations and reduce friction.

b. Tasks

- w Assist in planning and conducting landing force operations.
- w Assist in planning and conducting Civil Affairs (CA) activities, to include Civil-Military Operations (CMO).
- w Control subordinate CA units when assigned.
- w Plan and conduct survey, liaison and reconnaissance efforts to initiate and conduct CA activities.
- w Coordinate with appropriate staff officers at higher, adjacent, and lower commands.
- w Coordinate with non-MAGTF organizations and authorities.

c. Organization

A CAG is normally organized into a Group Headquarters and three Civil Affairs Detachments. The commanding officer and Group Headquarters provide CA support to the MEF, while the detachments are designed to support units of

the MEF to include the MEF(FWD). Each detachment is **the U.S. Marine Corps**; however, there are two CAGs further organized into International Law, Public Health, and assigned to MARFORRES. The 3d CAG is located Displaced Persons/Refugee functional teams, in addition to aboard Camp Pendleton, California and is under the operational control of MARFORPAC. The 4th CAG is located MEU-sized elements. **There are no active duty CAGs in** aboard Naval Station Anacostia in Washington, D.C. and is under the operational control of MARFORLANT. Both

TAM			
Number	Description	Quantity	Remarks
A0248	Central office, telephone, automatic, AN/TTC-42(V)	3	
A0258	Communications central, AN/MSC-63A	3	
A0274	Communications central (MECCS), AN/TSC-120	5	
A0311	Control central, communications, AN/TSQ-84	1	
A0499	Digital technical control (DTC)	3	FY99
A0655	Communications central, satellite, AN/TSC-96A	3	
A0812	Ground-mobile force satellite communications terminal, AN/TSC-85B(V)	1	
A0814	Terminal, communication, satellite, ground-mobile force, AN/TSC-93B(V)	4 (1 per MEU)	
A0818	SHF Tri-Band Advanced Range Extension Terminal (STAR-T)	8 (1 per MEU)	
A0918	Radio set, AN/PSC-5	36 (5 per MEU)	
A1955	Radio set, AN/MRC-142	27	
A1957	Radio set, AN/MRC-145	6 (2 per MEU)	
A2179	Radio set, troposcatter, digital, AN/TRC-170(V)5	8	
A2508	Switching unit, telephone, automatic, SB-3865		9 (1 per MEU)
A2532	Tactical combat operations (TCO)	4	
A2630	Technical control system, portable (PTC), AN/PTW-1	3	FY 01
A3232	Transportable TACSATCOM (SMART-T)	2	
B0605	Distribution system, power, electrical, 100 kW, P0100	9	3, FY01
B0730	Generator set, 3 kW, 60 Hz, MEF-016B	12	
B0891	Generator set, 10 kW, 60 Hz, MEP-083A	16	
B0953	Generator set, 30 kW, 60 Hz, MEP-005A	10	12, FY01
B1021	Generator set, 60 kW, 60 Hz, MEP-006A	2	
B1045	Generator set, 100 kW, 60 Hz, MEP-007B	6	
D0860	Trailer, cargo, 1 1/2 ton, M105A2	18	
D0880	Trailer, tank, water, 400 gal, M149A2	6	
D1059	Truck, cargo, 5 ton, 6 x 6, without winch, M923 3	34	
D1061	Truck, cargo, 5 ton, extra-large wide bed, M928	10	
D1092	Truck, maintenance, telephone, M876A1	6	
D1158	Truck, utility, cargo/troop carrier, 1/4 ton, HMMWV, M998	12	
D1212	Truck, wrecker, 5 ton, 6 x 6, M936	3	

Table 6-6. Selected Items of Equipment for the Communication Battalion. ¹²

¹²Equipment and quantities shown are drawn from the T/E for 8th Communications Battalion, II MEF, as of 22 October 1998. Refer to the following T/E for current information: 7th Communications Battalion, N4887; 8th Communications Battalion, N471; and 9th Communications Battalion, N4687. The quantities indicated are planned for the fiscal year shown. Numbers in the column are additional items planned for the fiscal year indicated.

CAGs provide support to active duty headquarters—both in real-world operations and exercises—on a constant basis through a variety of means and funding sources. The majority of billets in the CAG are for MOS 0107, CA Officer or 8441, CA NCO. These are secondary MOSs so members bring a wide variety of Primary MOSs, skills and experience to the CAG. See figure 6-10.

d. Concept of Employment

The CAG is organized to conduct CA activities in support of the MAGTF mission and may include Civil-Military Operations. Normally, these activities do not include sustained military or nation building/rebuilding operations. Whenever the MAGTF operates in an inhabited area, civilian populations will impact operations. CA elements and personnel are Economy of Force measures, intended to apply a few Marines with special perspective and training to the MAGTF’s planning and execution of operations. The CA staff element serves to promote civilian actions and attitudes helpful to the MAGTF and to minimize actions and attitudes harmful to the MAGTF. Typically, the assigned CA staff prepare assessments, agreements, and annexes in accordance with

the Joint Operations Planning and Execution System (JOPES) which support the commander’s plans and mission accomplishment. CA activities always support the commander’s legal and moral responsibilities under international and US law.

The MAGTF G/S-3 has primary staff cognizance over the CA efforts at the CE. Subordinate units plan and execute CA activities when useful or as directed, and may be assigned their own supporting CA elements or personnel. At the MEF level, the CA element may receive substantial direction from the Joint Force Commander’s CA staff

element or Joint Civil-Military Operations Task Force if organized. Coordination with all staff elements is important, but special consideration should be made to coordinate with Public Affairs and Psychological Operations staffs to support a common Information Operations campaign. Once the MAGTF is established ashore, CA forces may establish a Civil-Military Operations Center (CMOC) which serves as focal point of coordination between MAGTF and civilian planners.

While the CAGs are capable of limited self-administration, they depend on the supported unit for logistic, information systems, and communications support.

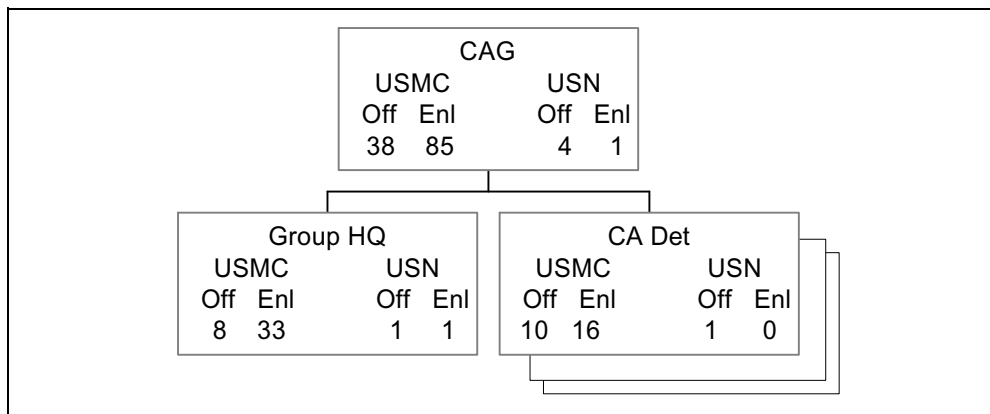

Figure 6-10. CAG Organization.

Appendix A

Glossary

AAV	assault amphibious vehicle	COMMARFORPAC	commander, Marine Corps Forces Pacific
AAW	antiair warfare	COMMARFORRES	commander, Marine Corps Forces Reserve
ACE	aviation combat element	COMSEC	communications security
AC/S	assistant chief of staff	CONUS	continental United States
ADAL	authorized dental allowance list	COTS	commercial off-the-shelf
ADCP	air defense communications platform	CP	command post
AE	assault echelon	CSS	combat service support
AFOE	assault follow-on echelon	CSSA	combat service support area
AMAL	authorized medical allowance list	CSSD	combat service support detachment
ARG	amphibious ready group	CSSE	combat service support element
ATC	air traffic control	DACG	departure airfield control group
ATF	amphibious task force	DAS	deep air support
AVLB	armored vehicle-launched bridge	DASC	direct air support center
BAS	battalion aid station	DF	direction finding
BDA	battle damage assessment	DOD	Department of Defense
BLT	battalion landing team	DPD	diver propulsion device
BSSG	brigade service support group	DTAMS	Digital Terrain Analysis and Mapping System
C4I	command, control, communications, computers, and intelligence	EA	electronic attack
CA	civil affairs	EOD	explosive ordnance disposal
CAG	civil affairs group	EPW	enemy prisoner of war
CAS	close air support	EW	electronic warfare
CATF	commander, amphibious task force	FARP	forward arming and refueling point
CE	command element	FCSSA	force combat service support area
CI	counterintelligence	FEBA	forward edge of the battle area
CINC	commander in chief	FIIU	force imagery interpretation unit
CIS	communications and information systems	FMF	Fleet Marine Force
CIT	counterintelligence team	FMFM	Fleet Marine Force manual
CLF	commander, landing force	FMFRP	Fleet Marine Force reference publication
COC	combat operations center	FOB	forward operating base
COMMARFORLANT	commander, Marine Corps Forces Atlantic	FSCC	fire support coordination center

FSSG	force service support group	MAFC	MAGTF all-source fusion center
FY	fiscal year	MAG	Marine aircraft group
GCE	ground combat element	MAG VF/VA	fixed-wing Marine air group
GMR	graduated mobilization response	MAG VH	rotary-wing Marine air group
H&HS	headquarters and headquarters squadron	MAGTF	Marine air-ground task force
H&S	headquarters and service	MALS	Marine aviation logistics squadron
HF	high frequency	MALSP	Marine aviation logistic support program
HMH	Marine heavy helicopter squadron	MARFOR	Marine Corps Forces
HMLA	Marine light/attack helicopter squadron	MARFORLANT	Marine Corps Forces Atlantic
HMM	Marine medium helicopter squadron	MARFORPAC	Marine Corps Forces Pacific
HMMWV	high-mobility, multipurpose wheeled vehicle	MARFORRES	Marine Corps Forces Reserve
HQMC	Headquarters, Marine Corps	MASS	Marine air support squadron
HUMINT	human intelligence	MATCD	Marine air traffic control detachment
IAS	intelligence analysis system	MAW	Marine air wing
IMA	individual mobilization augmentee	MCISU	Marine Corps Imagery Support Unit
IMINT	imagery intelligence	MCRP	Marine Corps reference publication
IRR	Individual Ready Reserve	MCSF	Marine Corps security forces
ISO	International Organization for Standardization	MCWP	Marine Corps warfighting publication
ITG	initial terminal guidance	MEF	Marine expeditionary force
JCS	Joint Chiefs of Staff	MEF(FWD)	MEF (forward)
JFC	joint force commander	METT-T	mission, enemy, terrain and weather, troops and support available-time available
JSIPS	Joint Services Imagery Processing System	MEU	Marine expeditionary unit
JTF	joint task force	MEU(SOC)	MEU (special operations capable)
JWICS	Joint Worldwide Intelligence Communications System	MEWSS	Mobile EW Support System
LAAD	low-altitude air defense	MGB	medium-girder bridge
LAN	local area network	MHE	materials handling equipment
LAR	light armored reconnaissance	MHG	MEF headquarters group
LAV	light armored vehicle	MOOTW	military operations other than war
LBSR	lightweight battlefield surveillance system	MP	military police
LCAC	landing craft air cushion	MPF	maritime prepositioning force
LFSP	landing force support party	MPLAN	Marine Corps Mobilization Management Plan
LSB	landing support battalion	MRAALS	Marine Remote Area Approach and Landing System
LVS	Logistics Vehicle System	MSSG	MEU service support group
MACCS	Marine Air Command and Control System	MTACS	Marine tactical air command squadron
MACE	MEF Augmentation CE	MWCS	Marine wing communications squadron
MACG	Marine air control group	MWHS	Marine wing headquarters squadron
MACS	Marine air control squadron	MWSG	Marine wing support group
		MWSS	Marine wing support squadron
		NBC	nuclear, biological, and chemical
		NCA	National Command Authorities
		NDI	nondevelopmental item
		NGF	naval gunfire
		NIMA	National Imagery and Mapping Agency
		NSF	naval surface fires

OAS	offensive air support	T/E	table of equipment
OPCON	operational control	T/O	table of organization
PIR	priority intelligence requirement	TACC	tactical air command center
PLGR	precise lightweight Global Positioning System receiver	TAOC	tactical air operations center
PLRS	Position Location Reporting System	TAOM	tactical air operations module
PP&P	packing, preservation, and packaging	TERPES	Tactical Electronic Reconnaissance Processing and Evaluation System
RAS	regiment aid station	TMD	theater missile defense
RSTA	reconnaissance, surveillance, and target acquisition	TMDE	test measurement diagnostic equipment
SAM	surface-to-air missile	TOW	tube-launched, optically tracked, wire command link guided missile
SAR	search and rescue	TRAP	tactical recovery of aircraft and personnel
SASSY	Supported Activities Supply System	TRCS	transportable recompression chamber system
SAW	squad automatic weapon	TRSS	tactical remote sensor system
SCAMP	sensor control and management platoon	TSCM	technical surveillance countermeasures
SCI	sensitive compartmented information	UAV	unmanned aerial vehicle
SCUBA	self-contained underwater breathing apparatus	UHF	ultrahigh frequency
SEAD	suppression of enemy air defense	UNAAF	unified action armed forces
SI	special intelligence	V/STOL	vertical/short takeoff and landing
SIGINT	signals intelligence	VHF	very high frequency
SIPRNET	Secret Internet Protocol Router Network	VMA	Marine attack squadron
SMAW	shoulder-launched multipurpose assault weapon	VMAQ	Marine tactical EW squadron
SMCR	Selected Marine Corps Reserve	VMFA	Marine fighter attack squadron
SPMAGTF	special-purpose MAGTF	VMFA(AW)	Marine all-weather fighter attack squadron
SSU	SIGINT support unit	VMGR	Marine aerial refueler transport squadron
		VMU	Marine unmanned aerial vehicle squadron
		VTOL	vertical takeoff and landing

WAN wide area network

XLWB extra-large wide bed